

UNITED STATES
DEPARTMENT OF THE INTERIOR
BUREAU OF LAND MANAGEMENT
Tillamook Field Office
4610 3rd Street
Tillamook, OR 97141

Coastal Chrome Timber Sale
ORN04-TS-2023.0402
Date: September 20, 2023

PROSPECTUS
SEALED BID

THIS IS A PROSPECTUS ONLY. ATTACHMENTS MAY NOT INCLUDE ALL EXHIBITS REFERRED TO IN THE CONTRACT. THE COMPLETE CONTRACT, INCLUDING ALL EXHIBITS, IS AVAILABLE FOR INSPECTION AT THE TILLAMOOK FIELD OFFICE.

NOTICE IS HEREBY GIVEN that the Bureau of Land Management will offer for sale timber as described herein for oral auction, pursuant to Instructions to Bidders, as stated on Form No. 5440-9. **Sealed bids will be received by the District Manager, or representative, at the Northwest Oregon District Office, 1717 Fabry Road, S.E., Salem, Oregon until 9:00am., Wednesday, September 20, 2023. Please call 503-375-5653 to make an appointment. Appointments are available from 8am - 4pm, M-F.** Sealed bids will be opened at 9:00 a.m. on Wednesday, September 20, 2023.

A WRITTEN BID on Form 5440-9 at not less than the appraised price on a unit basis per species and the required minimum bid deposit shall be required to participate in sealed bidding.

TO QUALIFY FOR PARTICIPATION in a sealed bid sale, the bidder must submit a bid in a sealed envelope for each tract offered that includes:

- 1. Two copies of the bid written on Form 5440-9, Deposit and Bid for Timber/Vegetative Resources. No bid for less than the advertised appraised price on a unit basis per species and total price can be considered.**
- 2. The required minimum bid deposit specified in the timber sale notice for the tract.**
- 3. A properly executed Independent Price Determination Certificate, Form 5430-11. A certification that the bid was arrived at by the bidder or offeror independently and was tendered without collusion with any other bidder or offeror.**
- 4. A completed Form 5450-17, Export Determination.**
- 5. The sealed envelope must be clearly marked that it is a “Bid for Timber” together with the sale name and number, the time and date of sale and a contact name and phone number of the bidder.**

THIS PROSPECTUS does not constitute the decision document for purposes of protest and appeal of a forest management decision. Consistent with 43 CFR Subpart 5003.2(b), the date the BLM posts the forest management decision on the BLM’s ePlanning website establishes the effective date of the decision for purposes of an administrative appeal. The decision was posted to the BLM’s ePlanning website on June 5, 2023, referring to the Upper Willamina Forest Management Project, DOI-BLM-ORWA-N040-2020-0001-EA.

AN ENVIRONMENTAL ASSESSMENT was prepared for Coastal Chrome timber sale tract, and a Finding of No Significant Impact has been documented. These documents are available for inspection as background for each timber sale tract at the Tillamook Field Office.

THE VOLUMES LISTED herein are estimates only. The sale volumes listed are based on 16-foot taper breaks which must be taken into consideration if comparisons are made with volume predictions based on other standards. The volumes based on 32-foot taper breaks are shown for comparison purposes. No sale shall be made for less than the advertised appraised price. The Purchaser shall be liable for the total purchase price, without regard to the amount bid per unit, even though the quantity of timber actually cut or removed or designated for taking is more or less than the estimated volume or quantity so listed.

THIS TIMBER SALE has been cruised based upon Eastside Scribner board foot measure. The minimum bid figures shown by species are dollars per thousand board feet (MBF). The minimum bid increment will be \$0.10 per MBF.

A PERFORMANCE BOND in an amount not less than 20 percent of the total purchase price will be required for all contracts of \$2,500 or more. A minimum performance bond of not less than \$500 will be required for all installment contracts less than \$2,500.

PRE-AWARD QUALIFICATIONS. The high bidder may be required to furnish information to determine the ability to perform the obligations of the contract. If the high bidder is determined not qualified, responsible or refuses to respond within fifteen (15) days of a request for information pertaining to qualifications, the contract may be offered and awarded for the high bid of the highest bidder who is qualified, responsible, and willing to accept the contract.

LOG EXPORT AND SUBSTITUTION: All timber sales, including timber from Federal rights-of-ways, shall be subject to the restrictions relating to the export and substitution of unprocessed timber from the United States in accordance with P.L. 94-165 and 43 CFR 5400 and 5420, as amended.

LOG EXPORT AND SUBSTITUTION RESTRICTIONS: Excepting Port-Orford-cedar, all timber offered for sale hereunder is restricted from export from the United States in the form of unprocessed timber and is prohibited from being used as a substitute for exported private timber. The BLM has revised the log export restrictions special provision to reduce the log branding and painting requirements. The new requirements include branding of one end of all logs with a scaling diameter of over 10 inches. All loads of 11 logs or more, regardless of the diameter of the logs, will have a minimum of 10 logs branded on one end. All logs will be branded on loads of 10 logs or less. One end of all branded logs will be marked with yellow paint. At the discretion of the Contracting Officer, the Purchaser may be required to brand and paint all logs. The Purchaser shall bear any increased costs for log branding and painting.

CONTRACT MODIFICATION, SUSPENSION OR TERMINATION: A revised Special Provision has been added to the contract which enables the Contracting Officer to suspend the contract to facilitate protection of certain plant or animal species, and/or to modify or terminate the contract when necessary to: (1) Comply with the Endangered Species Act or to prevent incidental take of northern spotted owls in accordance with management direction in the Record of Decision (ROD) and Resource Management Plan (RMP), or; (2) Comply with a court order, or; (3) Protect species which were identified for protection through survey and manage and/or protection buffer standards and guidelines or management direction established in the ROD and RMP.

ADDITIONAL INFORMATION concerning this timber sale tract is available at the above District Office. A copy of the timber sale contract is also available for inspection at the District Office. The prospectus for this sale is also available online at: <https://www.blm.gov/programs/natural-resources/forests-and-woodlands/timber-sales>. The prospectus includes maps and tables that cannot be made Section 508 compliant. For help with its data or information, please contact the Tillamook Field Office at 503-815-1100.

TIMBER SALE CONTRACT SPECIAL PROVISIONS

Sec. 43. Wood Products Reserved from CuttingRESERVED

- a. All timber in the Reserve and Clump Areas shown on Exhibit A and all trees that are painted orange and posted, which mark the boundaries of the Reserve Area.
- b. All trees marked with orange paint above and below stump height within the boundaries of the Cutting Areas shown on Exhibit A.
- c. All trees not marked for cutting with blue paint above and below stump height within the boundaries of the timber sale units 5, 7, 12, 13, 15, 24 shown on Exhibit A, except within road right-of-way posters.
- d. All conifer trees less than seven (7) inches diameter at breast height (dbh), and all hardwoods not listed on Exhibit B in the Contract Area shown on Exhibit A. If any are felled, they shall be retained on site.
- e. Existing down logs and snags in the Contract Area shown on Exhibit A, which do not present a safety hazard. All down logs and felled snags shall be retained on site.
- f. Trees felled within road rights-of-way, which are marked with yellow paint above and below stump height shall remain on site and be placed outside of the road prism.

Sec. 44. Special ProvisionsLOGGING

- a. Before beginning operations on the Contract Area for the first time or after a shutdown of seven (7) or more days, the Purchaser shall notify the Authorized Officer in writing of the date they plan to begin operations. This written notification must be received by the Authorized Officer no less than seven (7) days prior to the date the Purchaser plans to begin or resume operations. The Purchaser shall also notify the Authorized Officer in writing if they intend to cease operations for any period of seven (7) or more days.
- b. Prior to the commencement of operations, the Purchaser shall obtain from the Authorized Officer approval of a written operations and logging plan commensurate with the terms and conditions of the contract which shall include measures needed to assure protection of the environment and watershed. A pre-work conference between the Purchaser's authorized representative and the Authorized Officer must be held before the logging plan will be approved. All logging shall be done in accordance with the approved logging plan. The Purchaser shall provide a minimum of seven (7) days' notice when requesting the scheduling of a pre-work conference.

c. Excessive damage to reserve timber, as determined by the Authorized Officer, will result in suspension of yarding and felling operations until corrective measures to prevent further damages have been approved by the Authorized Officer.

d. No falling, yarding, or loading is permitted in or through the Reserve Areas, shown on Exhibit A, unless otherwise approved by the Authorized Officer.

e. Prior to attaching any logging equipment to a reserve tree, the Purchaser shall obtain approval from the Authorized Officer, and shall take precautions to protect the tree from damage as directed by the Authorized Officer.

f. The Purchaser shall provide two (2) flaggers to control traffic on the 4-7-27 road (Bald Mountain Road) whenever hazardous conditions are present from logging operations. The Purchaser shall not block or close the 4-7-27 road (Bald Mountain Road).

g. No hauling on road 4-7-27 (Bald Mountain Road) on any Saturday or Sunday from Memorial Day to Labor Day except when approved by Authorized Officer.

h. At all landings, all non-merchantable logs more than eight (8) inches in diameter at the large end and exceeding eight (8) feet in length shall be scattered or decked at a location designated by the Authorized Officer.

i. In skyline harvest areas all yarding shall be done with a skyline or similar cable system equipped with a carriage capable of yarding one thousand six hundred (1,600) feet slope distance from the landing and at least seventy-five (75) feet laterally from the skyline to the designated sky road. The carriage shall be capable of being held in position on the skyline during all lateral yarding and shall be able to pass intermediate support jacks as required. The leading end of all logs shall be transported free of the ground during yarding. Full suspension is required within fifty (50) feet of streams. The rigging of tail or lift trees, intermediate supports and use of tail holds outside the Cutting Areas shall be required where necessary to meet this requirement. Space designated skyline corridors at a minimum of one hundred fifty (150) feet apart unless otherwise agreed to in writing by the Authorized Officer.

j. Ground-based operations are limited to slopes of thirty-five (35) percent or less. The Authorized Officer may approve the use of specialized, ground-based, mechanized equipment (machines specifically designed to operate on slopes greater than 35%) on slopes of fifty (50) percent or less, except within two hundred ten (210) feet of streams. All skidding shall be done by equipment operated entirely on skid trails that have been approved by the Authorized Officer and use existing skid trails where available. The area composed of skid trails shall not exceed fifteen (15) percent of the total yarding area within a unit. Excavation on designated skid trails shall be limited to a maximum cut of one (1) foot unless otherwise approved by the Authorized Officer. The Purchaser shall directionally fall trees into the lead with the skidding direction and winch or carry the logs to the skid trails. Temporary logging roads, skid trails, and harvester/forwarder trails would be water barred and blocked as directed by the Authorized Officer, after each operating season before the fall wet season begins. Temporary logging roads, skid trails, and harvester/forwarder trails will be de-compacted/tilled and covered with slash as directed by the Authorized Officer.

k. Before cutting and removing any trees necessary to facilitate logging in the Cutting Areas

shown on Exhibit A, the Purchaser shall identify the location of skid trails, cable yarding roads, and tail hold, tieback, guy line, lift, intermediate support, and danger trees on the ground in a manner approved by the Authorized Officer at the pre-work conference and documented in the Logging Plan. Said Purchaser identification of trees to be cut and removed does not constitute authority to proceed with cutting and removal. In addition, before proceeding the following conditions must be met:

1. All skid roads and/or cable yarding roads upon which timber is identified by the Purchaser to be cut and removed in accordance with this special provision must be necessary for the safe and expeditious removal of timber sold under this contract and shall be limited to the minimum width necessary for yarding of logs with a minimum of damage to reserve trees, however, unless otherwise approved in writing by the Contracting Officer, the width of each skid road and/or cable yarding road shall be limited to twelve (12) feet.

2. The Purchaser may immediately cut and remove additional timber to clear skid trails and cable yarding roads; and provide tail hold, tieback, guy line, lift and intermediate support trees when the trees have been marked with blue or green paint above and below stump height by the Authorized Officer and thereby approved for cutting and removal by the Authorized Officer. When trees are marked with yellow paint above and below stump height, they may be cut but must remain on site. The volume of the timber to be sold will be determined by the Authorized Officer in accordance with Bureau of Land Management prescribed procedures. No timber may be cut or removed under terms of this provision unless sufficient installment payments have been made in accordance with Sec. 3(b) of the contract or sufficient bonding has been provided in accordance with Sec. 3(d) of the contract.

3. The Purchaser agrees that sale of this additional timber shall be accomplished by a unilateral modification of the contract executed by the Contracting Officer and that such timber shall be sold at the unit prices shown in Exhibit B of this contract unless: the value of the timber must be reappraised subject to the terms for contract extension set forth in Sec. 9. of the contract, or, the Authorized Officer determines that the tree species are not listed in Exhibit B of this contract and otherwise reserved in Sec. 43. of the contract or any tree that exceeds forty (40) inches dbh shall be appraised and sold by bilateral modification of the contract at current fair market value in accordance with Sec. 8. of the contract.

4. This authorization for the Purchaser to cut and remove additional timber prior to the execution of a modification may be withdrawn by the Contracting Officer if the Authorized Officer determines that the Purchaser has cut and removed any tree not previously marked and approved for cutting by the Authorized Officer, which under Sec. 10. of the contract constitutes a violation of the contract and under Sec. 13. of the contract may constitute a trespass rendering the Purchaser liable for damages under applicable law.

5. If authorization is withdrawn, the Contracting Officer shall issue a written notice to the Purchaser that the sale of additional timber under this special provision is no longer approved. In this case, the Purchaser shall inform the Authorized Officer at least one (1) working day prior to the need for cutting and removing any additional timber and execute a bilateral modification prior to cutting for such additional approved timber at the unit prices shown in Exhibit B of the contract or in accordance with Sec. 8. or Sec. 9. of the contract as determined by the Authorized Officer in accordance with this provision. The Contracting Officer may issue a

written order to the Purchaser to suspend, delay, or interrupt any or all contract work for the period deemed necessary and appropriate for the Government to safely measure and mark additional timber.

SEASONAL RESTRICTIONS

l. No cutting or yarding shall be conducted in Unit 1 and the Special Yarding Area shown on Exhibit A from April 1 to August 5 of the same calendar year both days inclusive. No cutting or yarding shall be conducted in Unit 1 and the Special Yarding Area in Unit 6 from August 6 to September 15 of the same calendar year from 2 hours before sunset to 2 hours after sunrise.

m. No road renovation, road construction, road improvement, or road decommissioning (except roadside brushing, which is permitted year-round), shown on Exhibit C, shall be conducted during the wet season (generally between October 16 of one calendar year to May 31 of the following calendar year), or during periods of wet soil conditions during the dry season, as determined by Authorized Officer.

n. No road renovation, road maintenance, or road decommissioning on 4-7-1.2 (Sta. 46+47 – 48+65), 4-7-11.2 (MP. 0.043 – 0.504, 0.655 – 0.962), and 5-7-15.0 (MP. 0.579 – 0.664), shown on Exhibit C, shall be conducted from April 1 to August 5 of the same calendar year both days inclusive, until August 6, 2024. No road renovation or road decommissioning on 4-7-1.2 (Sta. 46+47 – 48+65), 4-7-11.2 (MP. 0.043 – 0.504, 0.655 – 0.962), and 5-7-15.0 (MP. 0.579 – 0.664) shall be conducted from August 6 to September 15 of the same calendar year from 2 hours before sunset to 2 hours after sunrise, until August 6, 2024.

o. No mechanized falling or ground based equipment operation within harvest units shown on Exhibit A during the wet season (generally October 16 of one calendar year to May 31 of the following calendar year) and during periods of wet soil conditions as determined by the Authorized Officer. Based on site specific considerations, as determined by the Authorized Officer, some of these activities may be allowed during the seasonal restriction.

p. No cable yarding, log hauling, water hauling, or rock hauling on roads 4-6-7.4, 4-6-7.5, 4-6-18.1, 4-6-18.2, 4-7-11.2, 4-7-12.0A, 4-7-12.0B, 4-7-12.10, 4-7-12.11, 4-7-12.12, 4-7-13.0, 4-7-13.1, 4-7-13.2, 4-7-13.4, 4-7-13.5, 4-7-13.6, 4-7-13.7, 4-7-13.9, 4-7-13.10, 4-7-13.11, 4-7-14.3, 4-7-4.4, 4-7-14.11, 4-7-15.1, 4-7-15.8, 4-7-15.9, 4-7-15.11, 4-7-23.3, 4-7-24.0, 4-7-24.0B, 4-7-24.1, 4-7-24.2, 4-7-36.0, 5-7-11.0, 5-7-11.1, 5-7-11.2, 5-7-15.0, 5-7-15.1, 5-7-15.2, 5-7-15.3, 5-7-15.4, and 5-7-22.0), shown on Exhibit C, during the wet season (generally October 16 of one calendar year to May 31 of the following calendar year both days inclusive) and during periods of wet soil conditions as determined by Authorized Officer. Cable yarding and hauling may be allowed if the Purchaser, at their expense, elects to complete road work necessary to allow for wet season cable yarding and hauling, as determined by the Authorized Officer. Necessary road work will be determined on a road-by-road basis and may include, but is not limited to, rock surfacing, improving drainage features, and more frequent road maintenance.

q. No blasting shall be conducted in the Whip Up Flats Quarry (T. 04S., R. 07W., Section 23) from April 1 to September 15 of the same calendar year both days inclusive.

r. No road maintenance, as shown on Exhibit E, and described in Exhibit D, shall be conducted during periods of wet soil conditions as determined by the Authorized Officer.

s. No work in live streams shall be conducted between October 1 of one calendar year and July 14 of the following calendar year in the Yamhill River watershed, both days inclusive, unless BLM receives a waiver from the Oregon Department of Fish and Wildlife and is approved by the Authorized Officer.

t. The Purchaser shall post "Closed" signs on all existing OHV Trails and OHV Staging Areas within or near harvest units during active harvest operations. The Purchaser shall remove all logging debris and repair any damage that occurs to authorized OHV trails as a result of harvest activity, within ninety (90) days of completing harvest operations, as directed by the Authorized Officer.

ROAD CONSTRUCTION, RENOVATION, IMPROVEMENT, MAINTENANCE AND USE

u. The Purchaser shall haul only on the designated haul route, shown in the tables below and in Exhibit E, unless an alternative route is approved by the Authorized Officer. The designated haul route for Unit 1 through 25 is either 4-7-27.0 (Bald Mountain Access Road) towards Willamina or out 4-7-36.0 (Willamina Creek Road) towards Willamina. The designated haul route for Units 26 through 29 is out Indian Creek and SW Tindle Creek Road towards Willamina.

v. The Purchaser shall construct natural surfaced roads: 4-6-7.4 (Sta. 9+20 – 41+62), 4-6-7.5, 4-6-18.1, 4-6-18.2, 4-7-1.4 (MP. 0.649 – 0.672), 4-7-12.0B (Sta. 7+65 – 14+78), 4-7-12.10, 4-7-12.11, 4-7-12.12, 4-7-13.11, 4-7-15.11, 5-7-11.2, 5-7-15.3, and 5-7-15.4. The Purchaser shall construct rocked surfaced roads: 4-7-12.8, 4-7-12.9, 4-7-12.13, and 4-7-23.4. The Purchaser shall renovate natural surfaced roads: 4-6-7.4 (Sta. 0+00 – 9+20), 4-7-12.0B (Sta. 0+00 – 7+65), 4-7-13.2 (Sta. 14+30 – 16+70), 4-7-13.4, 4-7-14.4, 4-7-15.8, 4-7-15.9, 4-7-23.3, 4-7-36.0 (MP. 5.357 – 5.558), 5-7-11.0, 5-7-11.1, 5-7-15.0 (MP. 1.091 – 1.386), 5-7-15.1, and 5-7-15.2. The Purchaser shall renovate rocked surfaced roads: 4-7-1.2, 4-7-1.4 (MP. 0.000 – 0.649), 4-7-11.2, 4-7-12.0A, 4-7-12.1, 4-7-12.4, 4-7-12.5, 4-7-12.6, 4-7-13.0, 4-7-13.1, 4-7-13.2 (Sta. 0+00 – 14+30), 4-7-13.5, 4-7-13.6, 4-7-13.7, 4-7-13.9, 4-7-13.10, 4-7-14.3, 4-7-14.11, 4-7-15.1, 4-7-15.10 (Sta. 0+00 – 3+90), 4-7-24.0, 4-7-24.0B, 4-7-24.1, 4-7-24.2, 4-7-27.2, 4-7-36.0 (MP. 0.000 – 5.357), 5-7-3.0, 5-7-15.0 (MP. 0.000 – 1.091), and 5-7-22.0. The Purchaser shall improve rocked surfaced roads: 4-7-15.10 (Sta. 3+90 – 5+90). Construction, renovation, and improvement shall be done in strict accordance with the plans and specifications shown on Exhibit C, which is attached hereto and made a part hereof.

w. Any required construction, renovation, and improvement shall be completed and accepted prior to the removal of any timber, except right-of-way timber, over the road.

x. Any required construction, renovation, and improvement shall be completed and accepted prior to rock haul outside of the dry season (generally June 1 – October 15).

y. The Purchaser shall decommission 4-6-7.5, 4-6-18.1, 4-6-18.2, 4-7-12.0B, 4-7-12.10, 4-7-12.11, 4-7-12.12, 4-7-13.2 (Sta. 14+30 – 16+70), 4-7-13.4, 4-7-13.11, 4-7-14.4, 4-7-15.8, 4-7-15.9, 4-7-15.11, 4-7-23.3, 5-7-11.2, 5-7-15.3, and 5-7-15.4, as shown on Exhibit C, by subsoiling, installing non-drivable waterbars, scattering slash, removing culverts, spreading grass seed, and blocking. The

Purchaser shall decommission 4-6-7.4, 4-7-1.4 (MP. 0.649 – 0.672), 4-7-12.8, 4-7-12.9, 4-7-12.13, 4-7-24.0 (MP. 1.185 – 1.364), 4-7-24.0 B, 4-7-36.0 (MP. 5.357 – 5.558), 4-7-23.4, 5-7-11.0, 5-7-15.1, 5-7-15.2, and 5-7-15.0 (MP. 1.091 – 1.386), as shown on Exhibit C, by installing non-drivable waterbars, removing culverts, spreading grass seed, and blocking. The Purchaser shall stabilize 4-7-12.0A, 4-7-13.1, 4-7-13.2 (Sta. 0+00 – 14+30), 4-7-13.5, 4-7-13.6, 4-7-13.7, 4-7-24.2, and 5-7-11.1, as shown on Exhibit C, by installing drivable waterdips. Subsoiling shall consist of loosening the soil to a depth of eighteen (18) inches utilizing excavator attachments, log loader tongs, or other approved equipment acceptable to the Authorized Officer. No subsoiling shall be required where the road traverses rock outcroppings. All natural water courses shall be opened to prevent erosion of the road. Barriers shall be constructed and clearing debris shall be placed on and around the barriers to prevent further use of the road by vehicles as shown on Exhibit C. Decommissioning and stabilization shall be completed within thirty (30) days of completion of yarding and hauling operations on that road.

z. The Purchaser is authorized to use the roads listed below and shown on Exhibit E which are under the jurisdiction of the Bureau of Land Management for the removal of Government timber sold under the terms of this contract and/or the hauling of rock and water as required in Exhibit C, Exhibit D, and Exhibit E provided the Purchaser complies with the condition set forth in Sections 42.aa.

Road No. and Segment	Length Used	Road Control	Road Surface Type	Maintenance Responsibility
4-6-7.4	4,162 ft.	BLM	Natural	Purchaser
4-6-7.5	1,140 ft.	BLM	Natural	Purchaser
4-6-18.1	928 ft.	BLM	Natural	Purchaser
4-6-18.2	545 ft.	BLM	Natural	Purchaser
4-7-1.2	4,865 ft.	BLM	Rocked	Purchaser
4-7-1.4	0.672 mi.	BLM	Rocked and Natural	Purchaser
4-7-11.2	1.277 mi.	BLM	Rocked	Purchaser
4-7-12.0A	505 ft.	BLM	Rocked	Purchaser
4-7-12.0B	1,478 ft.	BLM	Natural	Purchaser
4-7-12.1	1,716 ft.	BLM	Rocked	Purchaser
4-7-12.4	0.050 mi.	BLM	Rocked	Purchaser
4-7-12.5	360 ft.	BLM	Rocked	Purchaser
4-7-12.6	143 ft.	BLM	Rocked	Purchaser
4-7-12.8	388 ft.	BLM	Rocked	Purchaser
4-7-12.9	1,528 ft.	BLM	Rocked	Purchaser
4-7-12.10	385 ft.	BLM	Natural	Purchaser
4-7-12.11	234 ft.	BLM	Natural	Purchaser
4-7-12.12	910 ft.	BLM	Natural	Purchaser
4-7-12.13	396 ft.	BLM	Rocked	Purchaser
4-7-13.0	0.148 mi.	BLM	Rocked	Purchaser
4-7-13.1	415 ft.	BLM	Rocked	Purchaser
4-7-13.2	1,670 ft.	BLM	Rocked and Natural	Purchaser
4-7-13.4	370 ft.	BLM	Natural	Purchaser
4-7-13.5	490 ft.	BLM	Rocked	Purchaser

4-7-13.6	0.565 mi.	BLM	Rocked	Purchaser
4-7-13.7	673 ft.	BLM	Rocked	Purchaser
4-7-13.9	588 ft.	BLM	Rocked	Purchaser
4-7-13.10	158 ft.	BLM	Rocked	Purchaser
4-7-13.11	473 ft.	BLM	Natural	Purchaser
4-7-14.3	3,078 ft.	BLM	Rocked	Purchaser
4-7-14.4	645 ft.	BLM	Natural	Purchaser
4-7-14.11	0.152 mi.	BLM	Rocked	Purchaser
4-7-15.8	688 ft.	BLM	Natural	Purchaser
4-7-15.9	670 ft.	BLM	Natural	Purchaser
4-7-15.10	590 ft.	BLM	Rocked	Purchaser
4-7-15.11	330 ft.	BLM	Natural	Purchaser
4-7-23.3	355 ft.	BLM	Natural	Purchaser
4-7-23.4	365 ft.	BLM	Rocked	Purchaser
4-7-24.0	1.364 mi.	BLM	Rocked	Purchaser
4-7-24.0B	2,010 ft.	BLM	Rocked	Purchaser
4-7-24.2	0.163 mi.	BLM	Rocked	Purchaser
4-7-27.2	0.771 mi.	BLM	Rocked	Purchaser
5-7-3.0	217 ft.	BLM	Rocked	Purchaser
5-7-11.0	280 ft.	BLM	Natural	Purchaser
5-7-11.1	535 ft.	BLM	Natural	Purchaser
5-7-11.2	985 ft.	BLM	Natural	Purchaser
5-7-15.0	1.386 mi.	BLM	Rocked and Natural	Purchaser
5-7-15.1	2,395 ft.	BLM	Natural	Purchaser
5-7-15.2	1,152 ft.	BLM	Natural	Purchaser
5-7-15.3	666 ft.	BLM	Natural	Purchaser
5-7-15.4	938 ft.	BLM	Natural	Purchaser
5-7-22.0	3.466 mi.	BLM	Rocked	Purchaser
4-7-36.0	5.558 mi.	BLM	Rocked and Natural	BLM
4-7-15.1	3.173 mi.	BLM	Rocked	BLM
4-7-27 (Bald Mtn. Access Road)	6.204 mi.	BLM	Paved	BLM
4-7-22.0	1.300 mi.	BLM	Paved	BLM

aa. The Purchaser shall perform any road repair and maintenance work on roads used and designated above, under the terms of Exhibit D, "Road Maintenance Specifications" of this contract which is attached hereto and made a part hereof. Purchaser shall spread **1,390** cubic yards of crushed rock on BLM controlled roads as directed by the Authorized Officer and as part of maintenance requirements, and stockpile **675** cubic yards of crushed rock for BLM maintenance requirements. Purchaser shall also pay a rockwear fee of thirty-five thousand three hundred seventy and 76/100 (\$35,370.76) dollars to the Government. Additional fees for rockwear will be calculated at the current rate for additional timber volume for BLM controlled roads and be charged to the Purchaser and be paid prior to contract termination. Purchaser shall also pay a maintenance fee of twenty-four thousand five hundred eighty-four and 28/100 (\$24,584.28) dollars to the Government. Additional fees for maintenance

will be calculated at the current rate for additional timber volume for BLM controlled roads and be charged to the Purchaser and be paid prior to contract termination. Final maintenance shall be completed no later than one (1) year after contract expiration unless otherwise approved by the Authorized Officer.

bb. In the use of the roads listed below and shown on Exhibit E, the Purchaser shall comply with the conditions of Right-of-Way and Road Use Agreement S-499 (OR044569) between the United States of America and Hampton Resources, Inc. & Hampton Tree Farms, Inc. The Purchaser will be required to enter into a license agreement with Hampton Resources, Inc. & Hampton Tree Farms, Inc. prior to commencement of operations. The Purchaser shall furnish to the Authorized Officer a copy of the required executed license agreement. The license agreement conditions include: 1) The Purchaser shall perform any road repair and maintenance work on road 4-7-24.1 (Seg. A1), under the terms of Exhibit D, "Road Maintenance Specifications", of this contract which is attached hereto and made a part hereof. 2) Default by the Purchaser of said Right-of-Way and Road Use Agreement or any license agreement executed pursuant thereto, shall be considered a violation of this contract. The amount of unpaid fees shall be considered as the amount of damage suffered by the Government because of the violation of this provision. The Purchaser will be required to carry liability insurance with the limits of \$2,000,000/\$2,000,000/\$2,000,000 and a performance bond of \$1,000.

Road No. and Segment	Length Used	Road Control	Road Surface Type	Maintenance Responsibility
4-7-24.1 (Seg. A1)	0.304 mi.	BLM Control - Hampton Ownership	Rocked	Purchaser

cc. The Purchaser agrees that if they request to use any other private road, subject of a right-of-way agreement with the Government for the removal of Government timber sold under the terms of this contract, and is approved by the Authorized Officer, Purchaser shall request and agree to the modification of this contract to provide for such use and for allowances for amortization of the Government's shares of the capital investment of any such road.

dd. With the prior written approval of the Authorized Officer, the Purchaser may arrange for cooperative maintenance with other users of roads included in Exhibit E; provided, that such cooperative arrangement shall not relieve the Purchaser of his liability for the maintenance and repair of such roads resulting from wear or damage, in accordance with this contract. The Purchaser shall furnish the Authorized Officer a copy of any cooperative maintenance agreements entered with other users of these roads.

ee. The Purchaser shall be responsible for repair of any damage to roads or structures caused by the use of overweight or over-dimension vehicles or equipment: (1) without written approval; (2) in violation of the conditions of a written approval; or (3) in a negligent manner. The amount of actual damage shall be determined by the Authorized Officer following a technical inspection and evaluation.

ff. The Purchaser shall perform any road repair and maintenance work on roads used (and designated as Purchaser Maintenance), under the terms of Exhibit D, "Road Maintenance Specifications", of this contract which is attached hereto and made a part hereof. Purchaser shall spread 5 cubic yards of crushed rock on non-BLM roads used for this timber sale, as directed by the Authorized Officer as part

of maintenance requirements.

gg. Tracked type equipment shall not be allowed to cross over concrete bridge decks, other concrete surfaced structures, or asphalt surfaced roads without the proper protection of that surface. Prior approval shall be obtained from the Authorized Officer when crossing with protective devices. No loading or yarding from asphalt surfaces is permitted.

ENVIRONMENTAL PROTECTION

hh. To prevent the spread of noxious weeds, the Purchaser shall pressure wash all road construction equipment (except dump trucks) and wash all ground-based logging equipment that will be used off of existing roads, as well as loaders and mechanically propelled brush cutters, prior to each entry onto the BLM Land shown on Exhibit A, as directed by the Authorized Officer. Cleaning shall be defined as removal of all dirt, grease, plant parts and material that may carry noxious weed seeds.

FIRE PREVENTION

ii. Primarily for purposes of fire prevention and control, the Purchaser shall, prior to the operation of power-driven equipment in construction or logging operations under this contract during the fire season or periods of fire danger, prepare a fire prevention and control plan to the satisfaction of the Authorized Officer. Purchaser shall take such measures for prevention and suppression of fire on the contract area and other adjacent Government lands used or traversed by Purchaser in connection with operations as are required by applicable laws and regulations. However, when in the opinion of the Authorized Officer, weather and other conditions affecting fire incidence and control make special precautions necessary to protect the contract area and said Government lands, Purchaser shall take such additional or other fire prevention and control measures as may be required by the Authorized Officer. The Purchaser shall comply with Oregon Department of Forestry Industrial Fire Precaution Level (IFPL) I Fire Season requirements. At IFPL II and III, additional fire prevention and control provisions may be added as determined by the Authorized Officer and specified in written instructions to the Purchaser to mitigate dry fuel and weather conditions.

LOGGING RESIDUE REDUCTION

jj. In addition to the requirements of Sec. 15 of this contract, and notwithstanding the Purchasers satisfactory compliance with State laws and regulations regarding offsetting or abating the additional fire hazard created by this operation and the States willingness to release the Purchaser from liability for such hazard, the Purchaser shall remain responsible to the Government for performance of the following hazard reduction measure(s) required by this contract: Perform logging residue reduction and site preparation work on approximately two hundred and twelve (212) acres of harvest area located within harvest units. The required work shall consist of any treatment or combination of treatments, as determined by the Authorized Officer, and specified in writing by the Contracting Officer. The number of acres of each treatment shall be determined by the Authorized Officer. Prior to commencement of any operation under this Section of the contract, a slash disposal and pre-work conference between the Purchaser's Representative and the Authorized Officer must be held at a location designated by the Authorized Officer. The number of acres of each treatment shall be determined by the Authorized Officer.

All slash disposals shall be done in accordance with the plans developed at this pre-work conference. Slash, as defined for this section, shall mean all material (brush, limbs, tops, unmerchantable stems, and chunks) severed or knocked over because of Purchaser's operations under the terms of this contract.

1. Excavator pile and burn slash within ground-based portion and along roads as directed by the Authorized Officer. Slash shall be piled by an excavator equipped with a hydraulic thumb. Finished piles shall be tight and free of dirt.

a. Unmerchantable logs greater than six (6) inches on the small end shall be left in place or positioned so that they will not be burned.

b. Slash depth of material less than six (6) inches in diameter would be less than one (1) foot high upon completion.

c. Machine piles shall be located as far as possible from retention trees, snags, or unit boundaries to minimize damage.

d. Machine piles shall be kept free of dirt and other non-wood debris and constructed as compactly as possible. There should be an adequate supply of finer fuels located within and under the covered area of the pile to ensure ignition of the larger fuels.

e. A minimum 10-foot by 10-foot cover of four (4) mil (0.004) inch thick polyethylene shall cap each machine pile to maintain a dry ignition point. The cover shall be firmly fixed to each pile to hold it in place. Plastic shall be held in place with woody debris or tied with rope or twine. The plastic must be secured so that it is held in place during strong wind conditions. The Purchaser is required to furnish the covering materials. Covering shall be completed as directed by the Authorized Officer.

f. Cutting Areas shall be piled during the same season that they are logged.

2. Slashing shall be completed as directed by the Authorized Officer.

a. All standing woody vegetation (brush), whips, and designated trees over one (1) foot in height shall be felled (slashed) and lopped into four (4) foot or smaller lengths in harvest units as directed by the Authorized Officer. Designated trees to be slashed include red alder and big leaf maple which are not otherwise reserved in Section 43 of this contract.

b. All logging slash and slashed woody vegetation that is greater than four (4) feet in length and between one (1) inch and six (6) inches in diameter shall be lopped if not being machine piled. Larger material which has a portion meeting this specification must be bucked at the six (6) inch diameter.

c. All woody vegetation, whips, and designated trees shall be completely severed from the stump(s). Stump height shall not exceed six (6) inches measured on the uphill side.

d. All western redcedar, western hemlock, Pacific madrone, Pacific dogwood, Oregon ash, and Oregon white oak, and Pacific yew trees shall be reserved and undamaged.

3. Pile and burn landing slash within thirty (30) feet of the edge of each landing, all tops, broken pieces, limbs, and debris more than one (1) inch in diameter at the large end and longer than three (3) feet in length shall be piled within fifteen (15) days of completion of hauling logs from that landing. Landing piles shall be kept free of dirt and located adjacent to roads at least twenty (20) feet from any Reserve Tree and/or as directed by the Authorized Officer. Upon completion of landing piling, the Purchaser shall prepare the landing piles for burning by securely covering each landing pile with four (4) mil (0.004) inch thick polyethylene plastic film at least 10 feet wide. Landing piles shall be covered sufficiently to allow for ignition in wet conditions as approved by the Authorized Officer. The plastic shall be oriented southwest to northeast. Pieces of burnable material shall be placed on top of the plastic to secure it from moving and to prevent it from blowing off during strong wind episodes. The Purchaser is required to furnish the covering materials. The timing of this covering work shall be in accordance with instructions from the Authorized Officer. No landing debris shall be dozed off the landing and covered with dirt. Debris which has been buried and is determined to be the source of holdover fire shall be excavated by the Purchaser, at the Purchaser's expense, with a tractor and/or hydraulic excavator as directed by the Authorized Officer. If the structure of the landing piles will not permit adequate consumption of piled debris by burning, the Purchaser shall re-pile them at the direction of the Authorized Officer.

4. Hand pile and cover up to 10 acres of slash concentrations of Harvest Areas as directed by the Authorized Officer. Slash shall be piled by hand. Finished piles shall be tight and free of dirt.

- (1) Hand piles shall be located as far as possible from reserve trees or unit boundaries to minimize damage. Slash shall not be piled on down logs, stumps, drainage ditches, turnouts, shoulders, cut banks, or within 10 feet of any other pile.
- (2) Slash between two (2) inches and six (6) inches in diameter on the large end, having a minimum length of two (2) feet shall be piled as directed by Authorized Officer. Piles shall be constructed by aligning individual pieces in the same direction and placing the heavier slash on top. Piles shall have a stable base to prevent toppling. The long axis of individual pieces shall be oriented up and down the slope. Pile size shall be a maximum of 8 feet in diameter by 8 feet in height, and minimum pile size shall be 6 feet in diameter by 5 feet in height at the time of final inspection by the Government. Slash left on the ground shall not exceed 6 inches in depth.
- (3) All piles shall be covered with black four (4) Mil polyethylene plastic to cover at least ninety (90) percent of the surface of each pile, minimum plastic size of 5' x 5'. There should be an adequate supply of finer fuels located within and under the covered area of the pile to ensure ignition of the larger fuels. Plastic shall be held in place with woody debris or tied with combustible cord. The plastic must be secured so that it is held in place during strong wind conditions and maintains

coverage for at least one year. The Purchaser is required to furnish the covering materials. Covering shall be done at time of piling.

- (4) Harvest Areas shall be piled within 30 days upon receiving notification from Authorized Officer.

kk. Notwithstanding the provisions of Sec. 15 of this contract, the Government shall assume all obligations for disposal or reduction of fire hazards created by Purchaser's operations on Government lands, except for burning and mop-up assistance as required herein, and measures required in Section 42(jj). The Purchaser shall, under supervision of the Authorized Officer or designated representative, assist in preparing units for burning, burning, mop-up, and patrol by furnishing, at the Purchaser's own expense, the services of personnel and equipment on each unit as shown below:

1. For Igniting, Burning, Mop-up of Piles on Units:

1. One work leader(s) Firefighter Type 1 (FFT1) qualified according to National Wildfire Coordinating Group (NWCG) Wildland Fire Qualifications System guide, PMS 310-1) to supervise crew and equipment operations, and to serve as Purchaser's representative.

2. Five-person crew Firefighter Type 2 (FFT2) qualified according to National Wildfire Coordination Group (NWCG) Wildland Fire Qualifications System guide, PMS 310-1, with sufficient fuel for burning, six (6) drip torches, one (1) power saw, and one (1) backpack pump, one (1) tool for each crew member.

3. The crew shall arrive on the project area with radios capable of inter-crew communications and communication with a BLM representative at a ratio of one (1) radio per every five (5) crewmembers.

4. All ignition and mop-up personnel will be directly supervised by a BLM representative.

Aircraft and pilots used for Logging Residue Reduction or the suppression of escaped fires from Logging Residue Reduction operations, shall be acquired from a list of aircraft and pilots approved (i.e., carded for these specific activities) by the Office of Aircraft Services or the U.S. Forest Service. This list is available from BLM District Offices upon request.

All listed personnel shall be physically fit, experienced, and fully capable of functioning as required. In addition, all listed personnel shall be qualified according to the National Wildfire Coordinating Group (NWCG) Wildland Fire Qualification System Guide, PMS-310-1 and provide documentation of these qualifications. On the day of ignition all listed personnel shall be fluent in speaking and understanding English, clothing shall consist of long pants and long-sleeved shirts and be of approved aramid fabric (Nomex™ or equivalent), as well as being free of diesel fuel oil. All personnel shall wear lug sole boots with minimum eight (8) inch tall uppers that provide ankle support, approved hardhats, and leather gloves. Personnel who do not meet these requirements or do not have proper clothing and personal

protective equipment (PPE) will not be allowed to participate. All listed tools and equipment shall be in good usable condition. All power-driven equipment shall be fully fueled and available for immediate use. During periods of use under this subsection, the Purchaser shall provide fuel and maintenance for all such power-driven equipment.

Except as provided hereafter for fire escapement, the Purchaser shall continue the required assistance in mop up on each cutting unit shown on Exhibit A for seventy-two (72) hours, as directed by the Authorized Officer within a five (5) day period commencing at 8:00 a.m. the day following the completion of ignition in that unit, or until released from such service by the Government, whichever occurs first.

In event of a fire escapement, the Purchaser's personnel and equipment shall, under supervision of the Authorized Officer, take action to control and mop up the escaped fire until released from such service by the Government. If it becomes necessary to use furnished personnel and equipment for the suppression of a fire which escapes from the prescribed fire area for a period beyond the remainder of the day in which the fire escapes, then the Government shall, at its option: (1) reimburse the Purchaser for such additional use of personnel and equipment at wage rates shown in the current Administratively Determined Pay Rates for the Western Area and at equipment rates shown in the current Oregon-Washington Interagency Fire Fighting Equipment Rental Rates schedule until the Purchaser is released from such service by the Government; or (2) release the Purchaser from additional suppression work and assume responsibility for suppressing the escaped fire.

In situations where an escaped fire is controlled and contained by an adequate fire break (i.e., trail, road, stream, rock formation, etc.), the Government may permit the Purchaser to remove personnel for that day; if all mop up work on the escaped fire is included with mop up work on the prescribed fire area. In such an event, the Purchaser must sign a statement of agreement to complete mop up work on all escaped fire areas concurrently with mop up work on the prescribed fire area.

In case of injury to personnel or damage to equipment furnished as required by this subsection, liability shall be borne by the Purchaser, unless such injury or damage is caused by Government negligence.

Time is of the essence in complying with this provision. In the event the Purchaser fails to provide the personnel and equipment required herein, the Purchaser shall be responsible for all additional cost incurred by the Government in disposing of slash including but not limited to the wages and other costs of providing federal employees and others as substitute labor force, the cost of providing substitute equipment and appropriate additional overhead expenses. If the Purchaser's failure results in a deferral of burning and new conditions necessitate additional personnel and equipment to accomplish the planned burn, the Purchaser also shall be responsible for such additional costs.

CREATION OF COARSE WOODY DEBRIS

II. In the Coarse Woody Debris Creation Units shown on Exhibit F, the Purchaser shall, upon completion of yarding, select and fall, top, high-girdle, or basal-girdle five thousand two hundred (5,200) live trees in accordance with Exhibit F. No adjustments of volume or value shall be made to meet these requirements. Coarse wood creation will be completed prior to contract expiration.

BUYOUT SECURITIES

mm. The Purchaser shall create coarse woody debris in accordance with Section 42.11. The Purchaser shall have the option of completing this work, or in lieu thereof, may make a buyout security deposit to the Bureau of Land Management in the amount of two hundred sixty-eight thousand, eight hundred twelve and 24/100 dollars (\$268,812.24), and upon making such deposit, the Purchaser shall be relieved of the obligations set out in this subsection. The purchaser may, alternately, complete the basal-girdle and felling coarse woody debris portion of Exhibit F and make a buyout security deposit in lieu of completing the topping and high-girdling portion of Exhibit F in the amount of one hundred sixty-four thousand, one hundred fifty and 76/100 dollars (\$164,150.76). The Purchaser shall notify the Authorized Officer of their intention to make this deposit prior to the date of execution of this contract and the Authorized Officer shall establish a required schedule of payments.

LOG EXPORT RESTRICTION

nn. Unless otherwise authorized in writing by the Contracting Officer, the Purchaser shall brand clearly and legibly one end of all logs with a scaling diameter (small end inside bark) of over ten (10) inches, prior to the removal of timber from the contract area. All loads of eleven (11) logs or more will have a minimum of ten (10) logs clearly and legibly branded on one end regardless of the diameter of the logs. All logs will be branded on loads of ten (10) logs or less. One end of all branded logs to be processed domestically will be marked with a three (3) square inch spot of highway yellow paint. The purchaser will stop trucks for accountability monitoring at mutually agreed upon locations when notified by the Authorized Officer.

If multiple trailers (mule trains) are used, each bunked load shall be considered an individual load, and these guidelines will apply to each bunked load. If a flatbed stake trailer is used, each bundle will be treated as a separate load.

At the discretion of the Contracting Officer, the Purchaser may be required to brand and paint all logs. Any increased costs for log branding and painting shall be the responsibility of the Purchaser.

TIMBER SALE NOTICE

NORTHWEST OREGON DISTRICT
TILLAMOOK FIELD OFFICE
COLUMBIA MASTER UNIT

Sale Date: September 20, 2023

CONTRACT NO.: ORN04-TS-2023.0402, Coastal Chrome Timber Sale, Lump Sum
TILLAMOOK AND YAMHILL COUNTY, OREGON: O&C, PD: **Sealed**
BID DEPOSIT REQUIRED: **\$175,800.00**

All timber designated for cutting on: SE¹/₄SW¹/₄, SW¹/₄SE¹/₄, **Sec. 06**; NW¹/₄NE¹/₄, **Sec. 07**; SW¹/₄SW¹/₄, **Sec. 18**; W¹/₂NW¹/₄, **Sec. 19**, T. 4 S., R. 6 W.; SE¹/₄SW¹/₄, S¹/₂SE¹/₄, **Sec. 01**; NE¹/₄, E¹/₂NW¹/₄, SW¹/₄, SE¹/₄, **Sec. 12**; NE¹/₄NE¹/₄, S¹/₂NE¹/₄, NW¹/₄NW¹/₄, SE¹/₄NW¹/₄, S¹/₂, **Sec. 13**; E¹/₂SW¹/₄, NW¹/₄SE¹/₄, **Sec. 14**; NE¹/₄, SE¹/₄NW¹/₄, N¹/₂SE¹/₄, **Sec. 15**; N¹/₂NE¹/₄, NE¹/₄NW¹/₄, **Sec. 23**; NE¹/₄, **Sec. 24**, T. 4 S., R. 7 W.; SW¹/₄, SW¹/₄SE¹/₄, **Sec. 11**; NE¹/₄NE¹/₄, S¹/₂NE¹/₄, S¹/₂NW¹/₄, SW¹/₄, N¹/₂SE¹/₄, SW¹/₄SE¹/₄, **Sec. 15**, T. 5 S., R. 7 W. WM., Oregon.

THIS TIMBER SALE HAS BEEN CRUISED BASED UPON EASTSIDE SCRIBNER MEASURE.

Minimum bid figures shown by species are dollars per thousand board feet (MBF). The minimum bid increment will be \$0.10 per MBF.

Approx. No. Merchantable Trees	Est. Vol. MBF 32' Log	Species	Est. Vol. MBF 16' Log	Appraised Price Per MBF	Estimated Volume Times Appraised Price
63,996	12,094	Douglas-Fir	15,025	\$111.40	\$1,673,785.00
2,685	1,397	Noble-Fir	1,711	\$45.90	\$ 78,534.90
85	59	Western Hemlock	72	\$46.30	\$ 3,333.60
1,445	41	Red Alder	63	\$25.80	\$ 1,625.40
299	9	Bigleaf Maple	12	\$26.30	\$ 315.60
68,510	13,600	Totals	16,883		\$1,757,594.50

*Minimum Stumpage values were used to compute the Appraised Price/MBF (10% of Pond Value)

LOG EXPORT AND SUBSTITUTION RESTRICTIONS: All timber offered for sale hereunder is restricted from export from the United States in the form of unprocessed timber and prohibited from substitution of exported private timber.

CRUISE INFORMATION: The timber volumes for the harvest units were based on a variable plot cruise for estimating the board foot volume of trees. Plots were measured using a 40 basal area factor (BAF) for regen units and thinning units with 16 MBF/ac. or greater. A 20 (BAF) was used in the rest of the thinning harvest units. Right of Way volume was 100% cruised. None of the total sale volume is salvage material. For merchantable Douglas- fir trees the average DBHOB is 15.0 inches; the average gross merchantable log contains 62 bf (board feet); the total gross volume is approximately 17,652 MBF; and 96% recovery is expected.

CUTTING AREA: Twenty-nine (29) units totaling approximately eight hundred eighty-three (883) acres, of which one hundred three (103) acres shall be regeneration harvest and seven hundred eighty (780) acres shall be partial cut harvest. These acres are inclusive of Patch Cut and Clump Areas as shown on Exhibit A. In addition, approximately eight (8) acres of right-of-way shall be cut. Acres shown on Exhibit A have been calculated based on Global Positioning System traverse procedures including differential correction.

DURATION OF CONTRACT: Contract length will be 48 months for cutting and removal of timber.

BUYOUT SECURITIES (Sec. 42.mm.): The Purchaser shall create coarse woody debris in accordance with Section 42.11. The Purchaser shall have the option of completing this work, or in lieu thereof, may make a buyout security deposit to the Bureau of Land Management in the amount of two hundred sixty-eight thousand, eight hundred twelve and 24/100 dollars (\$268,812.24), and upon making such deposit, the Purchaser shall be relieved of the obligations set out in this subsection. The Purchaser may, alternately, complete the basal-girdle and felling coarse woody debris portion of Exhibit F and make a buyout security deposit in lieu of completing the topping and high-girdling portion of Exhibit F in the amount of one hundred sixty-four thousand, one hundred fifty and 76/100 dollars (\$164,150.76). The Purchaser shall notify the Authorized Officer of their intention to make this deposit prior to the date of execution of this contract and the Authorized Officer shall establish a required schedule of payments.

LOCATION: The contract area is located approximately four (4) air miles north of Willamina, Oregon. Starting in Willamina, Oregon, head west on NE Main Street/Willamina Creek Road for 2.3 miles. Slight left onto SW Tindle Creek Road and continue for 1.9 miles. Slight right onto SW Indian Creek Road and continue for .8 miles. Stay left to stay on SW Indian Creek Road and continue for .3 miles where you will encounter Unit 29 of the Timber Sale. Consult a project location map.

ACCESS AND ROAD MAINTENANCE:

Access is provided by Hampton Resource, Inc. & Hampton Tree Farms, Inc., and the Bureau of Land Management (BLM) owned roads. All roads (except 4-7-15.1, 4-7-36.0 (MP. 0.000 – 4.675), and 4-7-27.0) used in conjunction with this sale will be maintained by the Purchaser. The Purchaser will be required to pay a rockwear obligation of thirty-five thousand three hundred seventy and 76/100 (\$35,370.76) dollars to the Government, pay a maintenance fee of twenty-four thousand five hundred eighty-four and 28/100 (\$24,584.28) dollars to the Government, spread **1,390 CY** crushed rock on BLM roads for maintenance, and stockpile **675 CY** crushed rock for BLM maintenance requirements.

In the use of Hampton Resource, Inc. & Hampton Trees Farms, Inc. owned roads, under Right-of-Way Agreement No. S-499 (OR044569) and as listed in section 43, the Purchaser will be required to enter into a license agreement which requires: (a) Purchaser maintenance of all Hampton Resource, Inc. & Hampton Trees Farms, Inc. owned roads, (b) Purchaser provide proof of insurance with limits of \$2,000,000/\$2,000,000/\$2,000,000 and a performance bond of \$1,000. Prior to the use of said roads, the Purchaser shall furnish the Authorized Officer a copy of the executed license agreement.

The designated haul route, as shown on Exhibit E, for Unit 1 through 25 is either 4-7-27.0 (Bald Mountain Access Road) towards Willamina or out 4-7-36.0 (Willamina Creek Road) towards Willamina. The designated haul route for Units 26 through 29 is out Indian Creek and SW Tindle Creek Road towards Willamina.

Rockwear fees have been calculated using timber volumes based on the actual BLM timber sale cruise volume. Additional fees for rockwear will be calculated at the agreed upon rates (in the license agreements) for additional timber volume for non-BLM owned roads. Additional fees for rockwear (and maintenance on the 4-7-27.0 (Bald Mountain Road)) will be calculated at the current rate for additional timber volume for BLM controlled roads and be charged to the Purchaser. Purchaser maintenance shall include frequent blading and shaping of road surface; ditch, culvert and catch basin cleaning; removal of minor slides and other debris. Roads shall be left in a condition to withstand adverse weather at the end of the seasonal operations.

Purchaser shall also spread **5 CY** crushed rock on non-BLM roads as needed and instructed by the Authorized Officer.

ROAD CONSTRUCTION AND RENOVATION: The Purchaser will be required to do all work set forth below. The Purchaser shall supply all material unless otherwise indicated.

1. New Road Construction:
Total Length: 142+87 Stations.
Road construction work to be performed is described in detail in Exhibit C and as shown on Exhibit A and C maps.

2. Renovation:
Total Length: 1,264+05 Stations
Road renovation work to be performed is described in detail in Exhibit C and as shown on Exhibit A and C maps.

3. Improvement:
Total Length: 2+00 Stations
Road improvement work to be performed is described in detail in Exhibit C and as shown on Exhibit A and C maps.

4. Estimated Quantities:
 - a. Clearing, Grubbing, and Brushing:
51.27 acres of Clearing and Grubbing
20.6 miles of Brushing

 - b. Culverts: Reference Exhibit C for details
4,925 feet of 18-inch Corrugated Plastic Pipe (CPP) – Type S--(128 Pipes)
190 feet of 18-inch Corrugated Plastic Pipe (CPP) – Type C--(16 Pipes)
40 feet of 18-inch Metal Half-Round Downspouts – (2 Pipes)
965 feet of 24-inch Corrugated Plastic Pipe (CPP) – Type S—(22 Pipes)
10 feet of 24-inch Corrugated Plastic Pipe (CPP) – Type C--(1 Pipes)
90 feet of 30-inch 14-gauge Aluminized Steel Pipe (CMP) – (2 Pipes)
420 feet of 36-inch 14-gauge Aluminized Steel Pipe (CMP) – (8 Pipes)
50 feet of 48-inch 14-gauge Aluminized Steel Pipe (CMP) – (1 Pipe)
Neoprene sleeves or flat gaskets for 30-inch, 36-inch, and 48-inch Pipe Bands Installations
221 Metal “T” Post Inlet Markers
40 Metal “T” Posts for Downspouts/Existing Half-Round Installations
84 Straw Bales for Sediment Catch Basin w/ Bale Installations

 - c. Aggregate Material & Rock Source: Reference Exhibit C and D for details

Whip Up Flats Quarry:
6,753 CY 6” Jaw Run Base Rock
3,192 CY 3”-0” Crushed Rock
10,731 CY 1 ½”-0” Crushed Rock
95 CY Pitrun Rock
1,448 CY Class 5 Rip-Rap

Commercial Source:
1,195 CY 6” Jaw Run Base Rock
2,160 CY 1 ½”-0” Crushed Rock
40 CY ¾” -0” Crushed Rock
80 CY Class 5 Rip-Rap

All rock required for project work in T. 05S., R. 07W., Sections 11 & 15 shall be obtained from a



United States Department of the Interior
 BUREAU OF LAND MANAGEMENT
 TIMBER SALE CONTRACT MAP

Contract No. ORN04-TS-2023.0402
 Coastal Chrome Timber Sale
 Exhibit A
 Page 1 of 6

5/31/2023

T. 4S. R. 6W, Sections 6 & 7 W. M. - NORTHWEST OREGON DISTRICT - OREGON

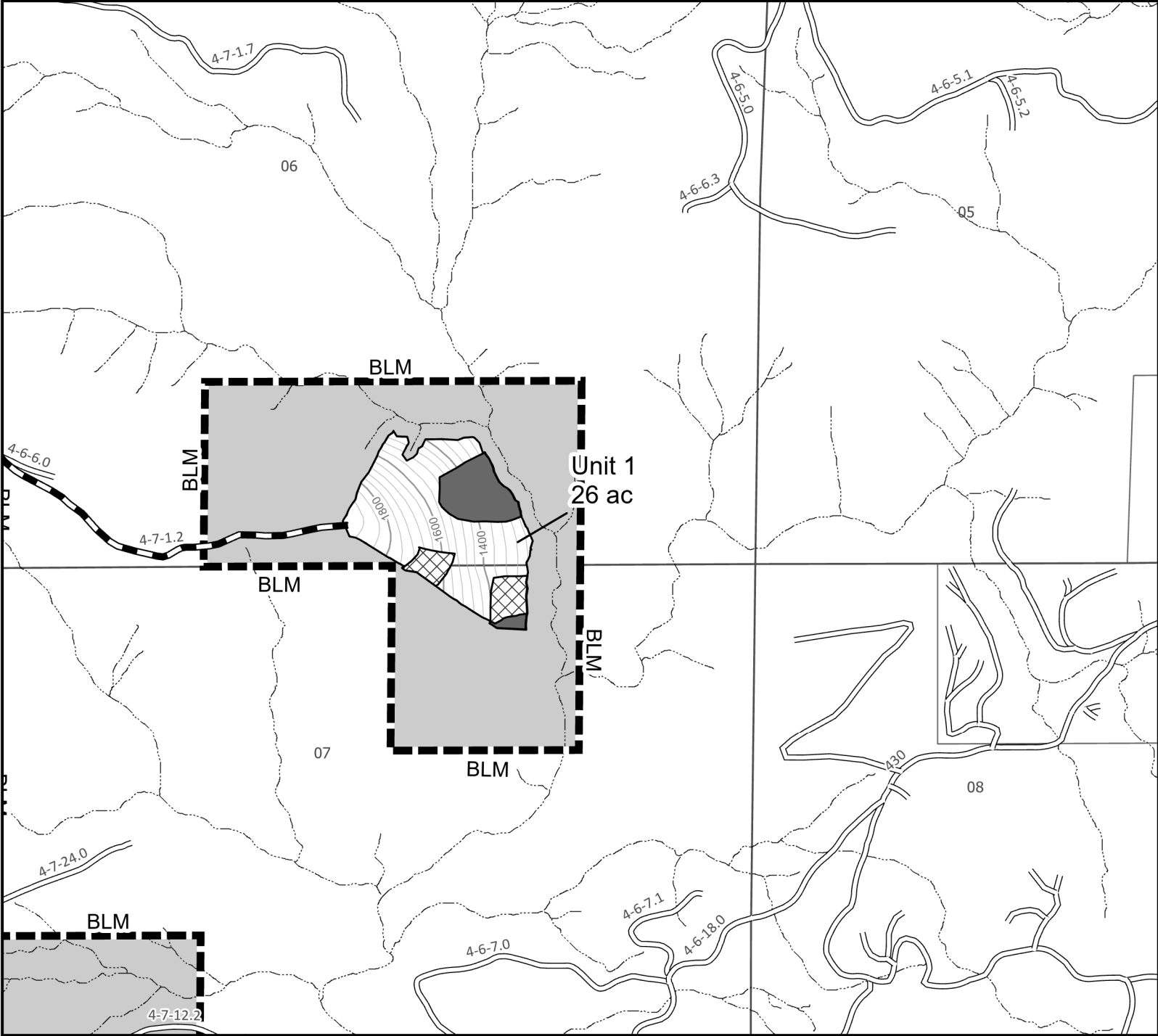

Partial Cut Area	780 acres
Regeneration Cut Area	103 acres
Right-of-Way	8 acres
Reserve Area	1958 acres
Clump	95 acres
Patch Cut	74 acres
Total Contract Area	2873 acres

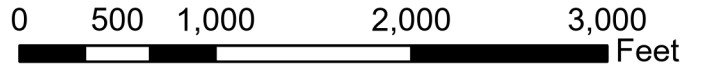

- Contract Area
- Reserve Area
- Partial Cut Area
- Regeneration Cut Area
- Special Yarding Area
- Patch Cut Area
- Clump Area
- Road Construct
- Road Improve
- Road Renovate
- Existing Road
- Streams

Contour Interval: 40 feet

No warranty is made by the Bureau of Land Management as to the accuracy, reliability, or completeness of these data for individual or aggregate use with other data. Original data were compiled from various sources and may be updated without notification. Note: Boundaries of harvest areas are painted/flagged in orange and posted. Right-of-ways (ROW) are posted. Harvest area acres do not include existing roads. Unit acres include Road Construct, Clump Areas, and Patch Cut Areas but do not include existing road areas. Prepared By: dtyler



United States Department of the Interior
 BUREAU OF LAND MANAGEMENT
 TIMBER SALE CONTRACT MAP

Contract No. ORN04-TS-2023.0402
 Coastal Chrome Timber Sale
 Exhibit A
 Page 2 of 6

5/31/2023

T. 4S. R. 7W, Sections 1, 12 & 13; T. 4S. R. 6W, Section 7 W. M. - NORTHWEST OREGON DISTRICT - OREGON

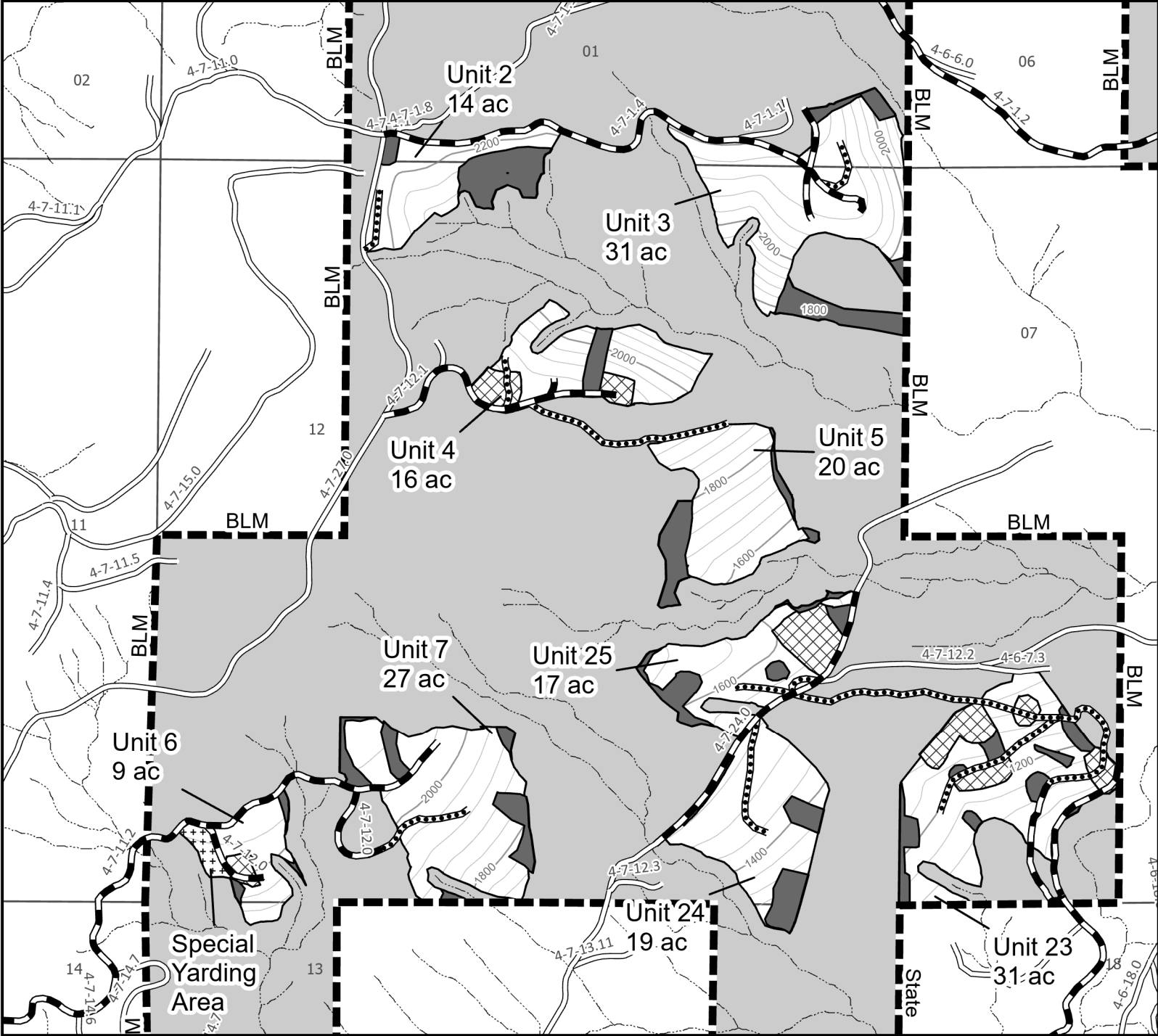

Partial Cut Area	780 acres
Regeneration Cut Area	103 acres
Right-of-Way	8 acres
Reserve Area	1958 acres
Clump	95 acres
Patch Cut	74 acres
Total Contract Area	2873 acres

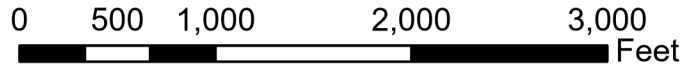

- Contract Area
- Reserve Area
- Partial Cut Area
- Regeneration Cut Area
- Special Yarding Area
- Patch Cut Area
- Clump Area
- Road Construct
- Road Improve
- Road Renovate
- Existing Road
- Streams

Contour Interval: 40 feet

No warranty is made by the Bureau of Land Management as to the accuracy, reliability, or completeness of these data for individual or aggregate use with other data. Original data were compiled from various sources and may be updated without notification. Note: Boundaries of harvest areas are painted/flagged in orange and posted. Right-of-ways (ROW) are posted. Harvest area acres do not include existing roads. Unit acres include Road Construct, Clump Areas, and Patch Cut Areas but do not include existing road areas. Prepared By: dtlyer



United States Department of the Interior
 BUREAU OF LAND MANAGEMENT
 TIMBER SALE CONTRACT MAP

Contract No. ORN04-TS-2023.0402
 Coastal Chrome Timber Sale
 Exhibit A
 Page 3 of 6

5/31/2023

T. 4S. R. 7W, Section 14, 15 & 23 W. M. - NORTHWEST OREGON DISTRICT - OREGON

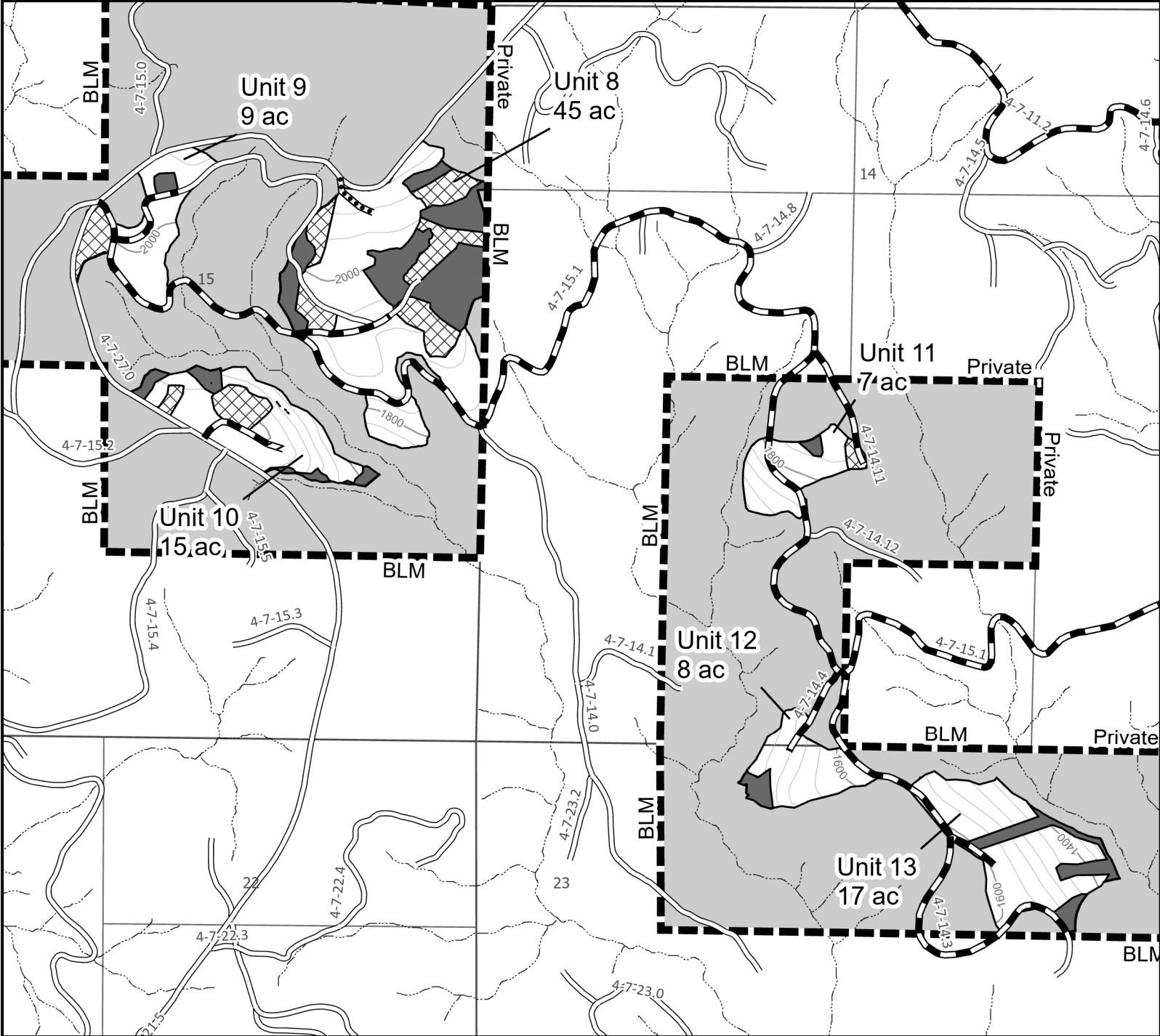

Partial Cut Area	780 acres
Regeneration Cut Area	103 acres
Right-of-Way	8 acres
Reserve Area	1958 acres
Clump	95 acres
Patch Cut	74 acres
Total Contract Area	2873 acres

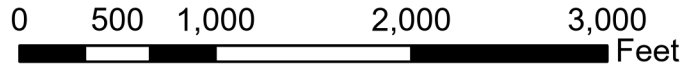

- Contract Area
- Road Construct
- Reserve Area
- Road Improve
- Partial Cut Area
- Road Renovate
- Regeneration Cut Area
- Existing Road
- Special Yarding Area
- Streams
- Patch Cut Area
- Clump Area

Contour Interval: 40 feet

No warranty is made by the Bureau of Land Management as to the accuracy, reliability, or completeness of these data for individual or aggregate use with other data. Original data were compiled from various sources and may be updated without notification. Note: Boundaries of harvest areas are painted/flagged in orange and posted. Right-of-ways (ROW) are posted. Harvest area acres do not include existing roads. Unit acres include Road Construct, Clump Areas, and Patch Cut Areas but do not include existing road areas. Prepared By: dtyler



United States Department of the Interior
 BUREAU OF LAND MANAGEMENT
 TIMBER SALE CONTRACT MAP

Contract No. ORN04-TS-2023.0402
 Coastal Chrome Timber Sale
 Exhibit A
 Page 4 of 6

5/31/2023

T. 4S. R. 7W, Sections 13 & 24; T. 4S. R. 6W, Sections 18 & 19 W. M. - NORTHWEST OREGON DISTRICT - OREGON

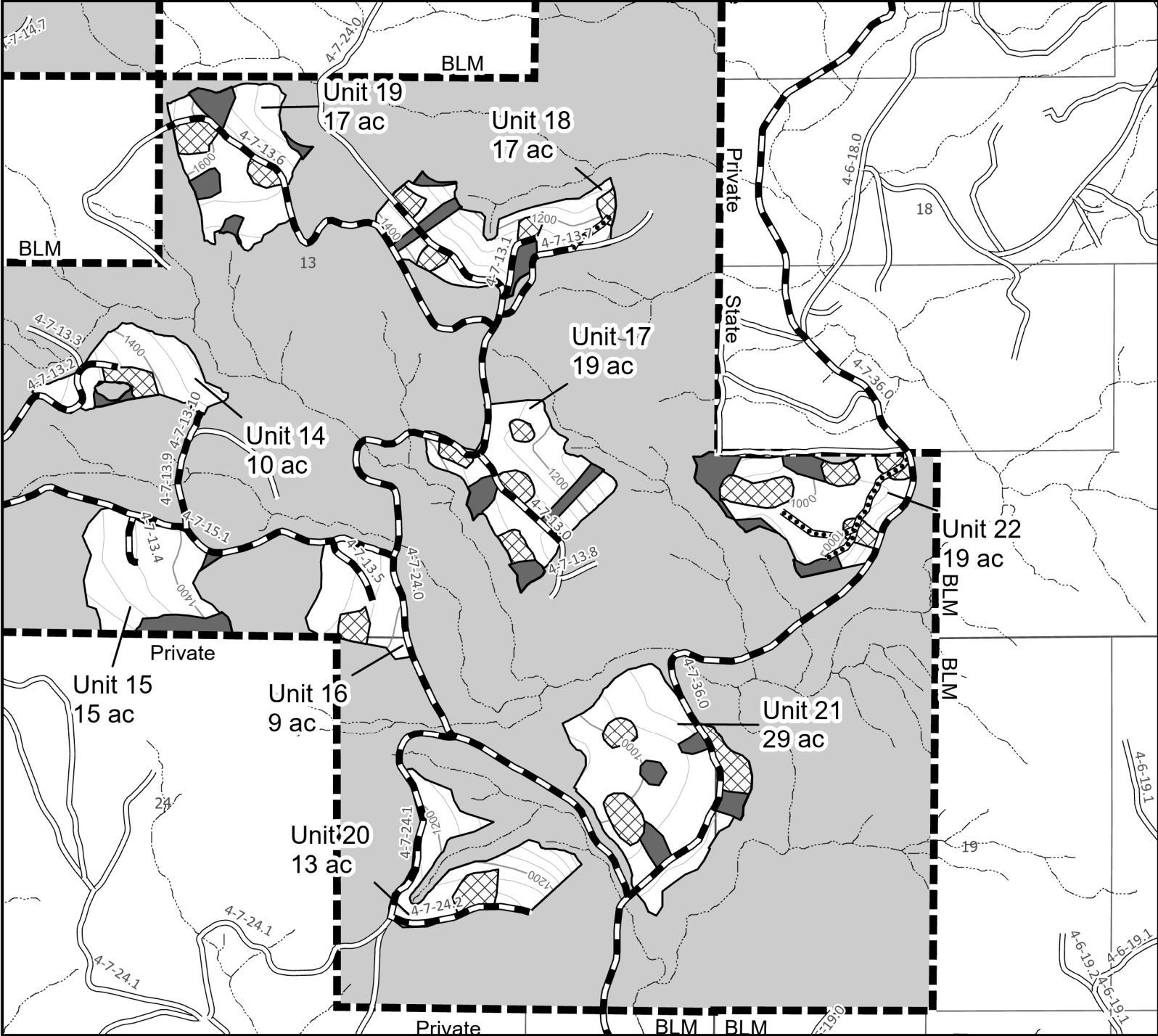

Partial Cut Area	780 acres
Regeneration Cut Area	103 acres
Right-of-Way	8 acres
Reserve Area	1958 acres
Clump	95 acres
Patch Cut	74 acres
Total Contract Area	2873 acres

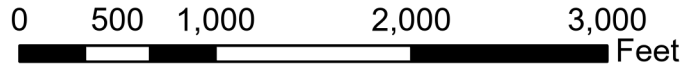

- Contract Area
- Reserve Area
- Partial Cut Area
- Regeneration Cut Area
- Special Yarding Area
- Patch Cut Area
- Clump Area
- Road Construct
- Road Improve
- Road Renovate
- Existing Road
- Streams

Contour Interval: 40 feet

No warranty is made by the Bureau of Land Management as to the accuracy, reliability, or completeness of these data for individual or aggregate use with other data. Original data were compiled from various sources and may be updated without notification. Note: Boundaries of harvest areas are painted/flagged in orange and posted. Right-of-ways (ROW) are posted. Harvest area acres do not include existing roads. Unit acres include Road Construct, Clump Areas, and Patch Cut Areas but do not include existing road areas.

Prepared By: dtyler



United States Department of the Interior
 BUREAU OF LAND MANAGEMENT
 TIMBER SALE CONTRACT MAP

Contract No. ORN04-TS-2023.0402
 Coastal Chrome Timber Sale
 Exhibit A
 Page 5 of 6

5/31/2023

T. 5S. R. 7W, Section 11 W. M. - NORTHWEST OREGON DISTRICT - OREGON

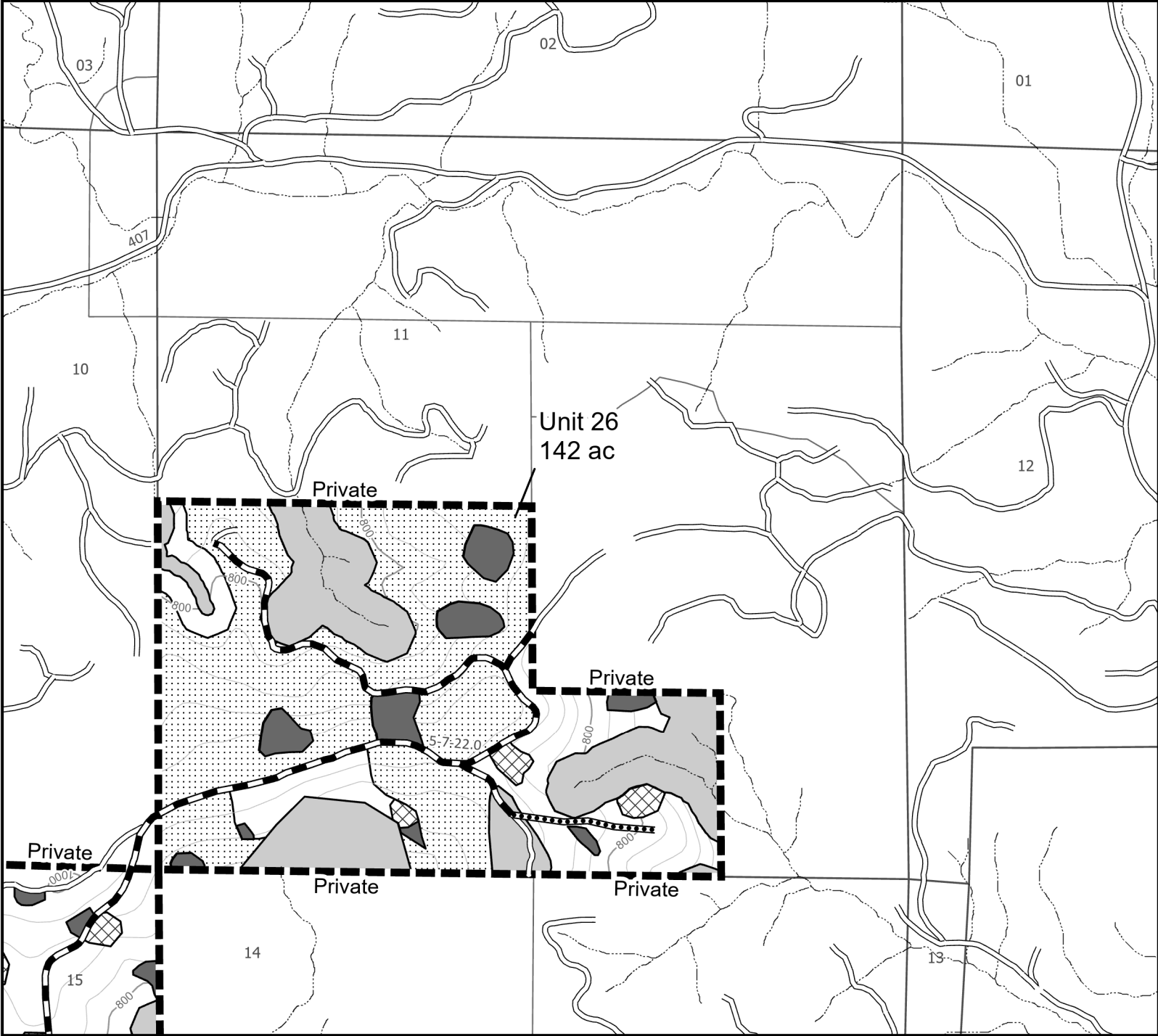

Partial Cut Area	780 acres
Regeneration Cut Area	103 acres
Right-of-Way	8 acres
Reserve Area	1958 acres
Clump	95 acres
Patch Cut	74 acres
Total Contract Area	2873 acres

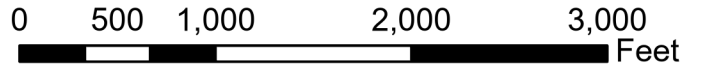

- Contract Area
- Reserve Area
- Partial Cut Area
- Regeneration Cut Area
- Special Yarding Area
- Patch Cut Area
- Clump Area
- Road Construct
- Road Improve
- Road Renovate
- Existing Road
- Streams

Contour Interval: 40 feet

No warranty is made by the Bureau of Land Management as to the accuracy, reliability, or completeness of these data for individual or aggregate use with other data. Original data were compiled from various sources and may be updated without notification. Note: Boundaries of harvest areas are painted/flagged in orange and posted. Right-of-ways (ROW) are posted. Harvest area acres do not include existing roads. Unit acres include Road Construct, Clump Areas, and Patch Cut Areas but do not include existing road areas.

Prepared By: dtyler



United States Department of the Interior
 BUREAU OF LAND MANAGEMENT
 TIMBER SALE CONTRACT MAP

Contract No. ORN04-TS-2023.0402
 Coastal Chrome Timber Sale
 Exhibit A
 Page 6 of 6

5/31/2023

T. 5S. R. 7W, Section 15 W. M. - NORTHWEST OREGON DISTRICT - OREGON

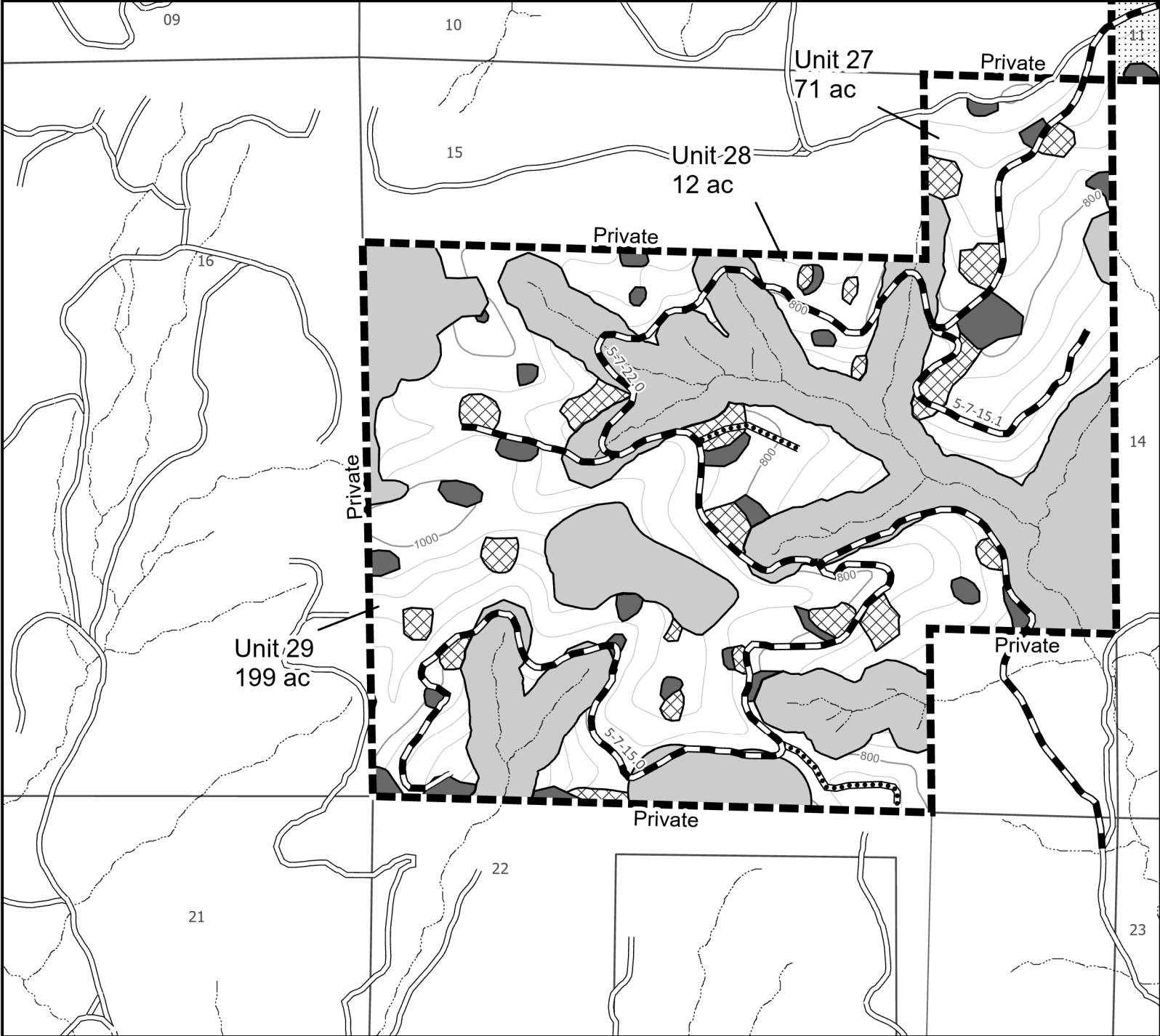

Partial Cut Area	780 acres
Regeneration Cut Area	103 acres
Right-of-Way	8 acres
Reserve Area	1958 acres
Clump	95 acres
Patch Cut	74 acres
Total Contract Area	2873 acres

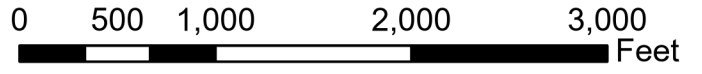

- Contract Area
- Reserve Area
- Partial Cut Area
- Regeneration Cut Area
- Special Yarding Area
- Patch Cut Area
- Clump Area
- Road Construct
- Road Improve
- Road Renovate
- Existing Road
- Streams

Contour Interval: 40 feet

No warranty is made by the Bureau of Land Management as to the accuracy, reliability, or completeness of these data for individual or aggregate use with other data. Original data were compiled from various sources and may be updated without notification. Note: Boundaries of harvest areas are painted/flagged in orange and posted. Right-of-ways (ROW) are posted. Harvest area acres do not include existing roads. Unit acres include Road Construct, Clump Areas, and Patch Cut Areas but do not include existing road areas. Prepared By: dtyler

UNITED STATES
DEPARTMENT OF THE INTERIOR
BUREAU OF LAND MANAGEMENT

EXHIBIT B / PRE-SALE

5450-003

Contract No.

ORN04-TS-2023.0402

Coastal Chrome

The following estimates and calculations of value of timber sold are made solely as an administrative aid for determining: (1) adjustments made or credits given in accordance with Secs. 6, 9, or 11; (2) when payments are due; and (3) value of timber subject to any special bonding provisions. The value of timber will be determined by multiplying the value per acre as shown below, times the amount of acreage as determined by the Authorized Officer, which has been cut or removed or designated for taking. Except as provided in Sec. 2, Purchaser shall be liable for total purchase price even though quantity of timber actually cut or removed or designated for taking is less than the estimated volume or quantity shown. Cutting areas are shown on **Exhibit A**.

SPECIES	ESTIMATED VOLUME OR QUANTITY <i>(Units Specified)</i>		PRICE PER UNIT	ESTIMATED VOLUME OR QUANTITY X UNIT PRICE
Douglas Fir	15,025.0	MBF	\$111.40	\$1,673,785.00
Noble Fir	1,711.0	MBF	\$45.90	\$78,534.90
Western Hemlock	72.0	MBF	\$46.30	\$3,333.60
Red Alder	63.0	MBF	\$25.80	\$1,625.40
Bigleaf Maple	12.0	MBF	\$26.30	\$315.60
TOTALS	16,883.0	MBF		\$1,757,594.50

The apportionment of the total purchase price is as follows:

Unit 1

Douglas Fir	295.0 MBF	X	\$111.40 =	\$32,863.00
Red Alder	4.0 MBF	X	\$25.80 =	\$103.20
Total	299.0 Mbf			\$32,966.20 ÷ 26.0 acres = \$1,267.93/Acre

Unit 2

Douglas Fir	141.0 MBF	X	\$111.40 =	\$15,707.40
Red Alder	2.0 MBF	X	\$25.80 =	\$51.60
Total	143.0 Mbf			\$15,759.00 ÷ 14.0 acres = \$1,125.64/Acre

Unit 3

Douglas Fir	380.0 MBF	X	\$111.40 =	\$42,332.00
Red Alder	5.0 MBF	X	\$25.80 =	\$129.00
Total	385.0 Mbf			\$42,461.00 ÷ 31.0 acres = \$1,369.71/Acre

Unit 4

Douglas Fir	211.0 MBF	X	\$111.40 =	\$23,505.40
Red Alder	3.0 MBF	X	\$25.80 =	\$77.40
Total	214.0 Mbf			\$23,582.80 ÷ 16.0 acres = \$1,473.93/Acre

Unit 5

Douglas Fir	346.0 MBF	X	\$111.40 =	\$38,544.40
Total	346.0 Mbf			\$38,544.40 ÷ 20.0 acres = \$1,927.22/Acre

Unit 6

Douglas Fir	113.0 MBF	X	\$111.40 =	\$12,588.20
Red Alder	1.0 MBF	X	\$25.80 =	\$25.80

UNITED STATES
DEPARTMENT OF THE INTERIOR
BUREAU OF LAND MANAGEMENT

EXHIBIT B / PRE-SALE

5450-003

Contract No.

ORN04-TS-2023.0402

Coastal Chrome

The following estimates and calculations of value of timber sold are made solely as an administrative aid for determining: (1) adjustments made or credits given in accordance with Secs. 6, 9, or 11; (2) when payments are due; and (3) value of timber subject to any special bonding provisions. The value of timber will be determined by multiplying the value per acre as shown below, times the amount of acreage as determined by the Authorized Officer, which has been cut or removed or designated for taking. Except as provided in Sec. 2, Purchaser shall be liable for total purchase price even though quantity of timber actually cut or removed or designated for taking is less than the estimated volume or quantity shown. Cutting areas are shown on **Exhibit A**.

Total	114.0 Mbf		\$12,614.00	÷	9.0 acres = \$1,401.56/Acre
-------	-----------	--	-------------	---	-----------------------------

Unit 7

Douglas Fir	498.0 MBF	X	\$111.40	=	\$55,477.20
<hr/>					
Total	498.0 Mbf		\$55,477.20	÷	27.0 acres = \$2,054.71/Acre

Unit 8

Douglas Fir	464.0 MBF	X	\$111.40	=	\$51,689.60
Red Alder	6.0 MBF	X	\$25.80	=	\$154.80
<hr/>					
Total	470.0 Mbf		\$51,844.40	÷	45.0 acres = \$1,152.10/Acre

Unit 9

Douglas Fir	127.0 MBF	X	\$111.40	=	\$14,147.80
Red Alder	2.0 MBF	X	\$25.80	=	\$51.60
<hr/>					
Total	129.0 Mbf		\$14,199.40	÷	9.0 acres = \$1,577.71/Acre

Unit 10

Douglas Fir	183.0 MBF	X	\$111.40	=	\$20,386.20
Red Alder	2.0 MBF	X	\$25.80	=	\$51.60
<hr/>					
Total	185.0 Mbf		\$20,437.80	÷	15.0 acres = \$1,362.52/Acre

Unit 11

Douglas Fir	98.0 MBF	X	\$111.40	=	\$10,917.20
Red Alder	1.0 MBF	X	\$25.80	=	\$25.80
<hr/>					
Total	99.0 Mbf		\$10,943.00	÷	7.0 acres = \$1,563.29/Acre

Unit 12

Douglas Fir	152.0 MBF	X	\$111.40	=	\$16,932.80
<hr/>					
Total	152.0 Mbf		\$16,932.80	÷	8.0 acres = \$2,116.60/Acre

Unit 13

Douglas Fir	303.0 MBF	X	\$111.40	=	\$33,754.20
<hr/>					
Total	303.0 Mbf		\$33,754.20	÷	17.0 acres = \$1,985.54/Acre

UNITED STATES
DEPARTMENT OF THE INTERIOR
BUREAU OF LAND MANAGEMENT

Contract No.
ORN04-TS-2023.0402
Coastal Chrome

EXHIBIT B / PRE-SALE

5450-003

The following estimates and calculations of value of timber sold are made solely as an administrative aid for determining: (1) adjustments made or credits given in accordance with Secs. 6, 9, or 11; (2) when payments are due; and (3) value of timber subject to any special bonding provisions. The value of timber will be determined by multiplying the value per acre as shown below, times the amount of acreage as determined by the Authorized Officer, which has been cut or removed or designated for taking. Except as provided in Sec. 2, Purchaser shall be liable for total purchase price even though quantity of timber actually cut or removed or designated for taking is less than the estimated volume or quantity shown. Cutting areas are shown on **Exhibit A**.

Unit 14

Douglas Fir	141.0 MBF	X	\$111.40	=	\$15,707.40
Red Alder	2.0 MBF	X	\$25.80	=	\$51.60
Total	143.0 Mbf				\$15,759.00 ÷ 10.0 acres = \$1,575.90/Acre

Unit 15

Douglas Fir	281.0 MBF	X	\$111.40	=	\$31,303.40
Total	281.0 Mbf				\$31,303.40 ÷ 15.0 acres = \$2,086.89/Acre

Unit 16

Douglas Fir	127.0 MBF	X	\$111.40	=	\$14,147.80
Red Alder	2.0 MBF	X	\$25.80	=	\$51.60
Total	129.0 Mbf				\$14,199.40 ÷ 9.0 acres = \$1,577.71/Acre

Unit 17

Douglas Fir	225.0 MBF	X	\$111.40	=	\$25,065.00
Red Alder	3.0 MBF	X	\$25.80	=	\$77.40
Total	228.0 Mbf				\$25,142.40 ÷ 19.0 acres = \$1,323.28/Acre

Unit 18

Douglas Fir	211.0 MBF	X	\$111.40	=	\$23,505.40
Red Alder	3.0 MBF	X	\$25.80	=	\$77.40
Total	214.0 Mbf				\$23,582.80 ÷ 17.0 acres = \$1,387.22/Acre

Unit 19

Douglas Fir	197.0 MBF	X	\$111.40	=	\$21,945.80
Red Alder	3.0 MBF	X	\$25.80	=	\$77.40
Total	200.0 Mbf				\$22,023.20 ÷ 17.0 acres = \$1,295.48/Acre

Unit 20

Douglas Fir	183.0 MBF	X	\$111.40	=	\$20,386.20
Red Alder	2.0 MBF	X	\$25.80	=	\$51.60
Total	185.0 Mbf				\$20,437.80 ÷ 13.0 acres = \$1,572.14/Acre

UNITED STATES
DEPARTMENT OF THE INTERIOR
BUREAU OF LAND MANAGEMENT

Contract No.

ORN04-TS-2023.0402

EXHIBIT B / PRE-SALE

Coastal Chrome

5450-003

The following estimates and calculations of value of timber sold are made solely as an administrative aid for determining: (1) adjustments made or credits given in accordance with Secs. 6, 9, or 11; (2) when payments are due; and (3) value of timber subject to any special bonding provisions. The value of timber will be determined by multiplying the value per acre as shown below, times the amount of acreage as determined by the Authorized Officer, which has been cut or removed or designated for taking. Except as provided in Sec. 2, Purchaser shall be liable for total purchase price even though quantity of timber actually cut or removed or designated for taking is less than the estimated volume or quantity shown. Cutting areas are shown on **Exhibit A**.

Unit 21

Douglas Fir	366.0 MBF	X	\$111.40	=	\$40,772.40
Red Alder	5.0 MBF	X	\$25.80	=	\$129.00
Total	371.0 Mbf				\$40,901.40 ÷ 29.0 acres = \$1,410.39/Acre

Unit 22

Douglas Fir	211.0 MBF	X	\$111.40	=	\$23,505.40
Red Alder	3.0 MBF	X	\$25.80	=	\$77.40
Total	214.0 Mbf				\$23,582.80 ÷ 19.0 acres = \$1,241.20/Acre

Unit 23

Douglas Fir	380.0 MBF	X	\$111.40	=	\$42,332.00
Red Alder	5.0 MBF	X	\$25.80	=	\$129.00
Total	385.0 Mbf				\$42,461.00 ÷ 31.0 acres = \$1,369.71/Acre

Unit 24

Douglas Fir	368.0 MBF	X	\$111.40	=	\$40,995.20
Total	368.0 Mbf				\$40,995.20 ÷ 19.0 acres = \$2,157.64/Acre

Unit 25

Douglas Fir	197.0 MBF	X	\$111.40	=	\$21,945.80
Red Alder	3.0 MBF	X	\$25.80	=	\$77.40
Total	200.0 Mbf				\$22,023.20 ÷ 17.0 acres = \$1,295.48/Acre

Unit 26

Douglas Fir	3,997.0 MBF	X	\$111.40	=	\$445,265.80
Noble Fir	1,084.0 MBF	X	\$45.90	=	\$49,755.60
Bigleaf Maple	4.0 MBF	X	\$26.30	=	\$105.20
Total	5085.0 Mbf				\$495,126.60 ÷ 142.0 acres = \$3,486.81/Acre

Unit 27

Douglas Fir	1,027.0 MBF	X	\$111.40	=	\$114,407.80
Noble Fir	153.0 MBF	X	\$45.90	=	\$7,022.70
Bigleaf Maple	2.0 MBF	X	\$26.30	=	\$52.60
Total	1182.0 Mbf				\$121,483.10 ÷ 71.0 acres = \$1,711.03/Acre

UNITED STATES
DEPARTMENT OF THE INTERIOR
BUREAU OF LAND MANAGEMENT

Contract No.
ORN04-TS-2023.0402
Coastal Chrome

EXHIBIT B / PRE-SALE

5450-003

The following estimates and calculations of value of timber sold are made solely as an administrative aid for determining: (1) adjustments made or credits given in accordance with Secs. 6, 9, or 11; (2) when payments are due; and (3) value of timber subject to any special bonding provisions. The value of timber will be determined by multiplying the value per acre as shown below, times the amount of acreage as determined by the Authorized Officer, which has been cut or removed or designated for taking. Except as provided in Sec. 2, Purchaser shall be liable for total purchase price even though quantity of timber actually cut or removed or designated for taking is less than the estimated volume or quantity shown. Cutting areas are shown on **Exhibit A**.

Unit 28

Douglas Fir	171.0 MBF	X	\$111.40	=	\$19,049.40
Noble Fir	26.0 MBF	X	\$45.90	=	\$1,193.40
Total	197.0 Mbf				\$20,242.80 ÷ 12.0 acres = \$1,686.90/Acre

Unit 29

Douglas Fir	2,926.0 MBF	X	\$111.40	=	\$325,956.40
Noble Fir	437.0 MBF	X	\$45.90	=	\$20,058.30
Bigleaf Maple	5.0 MBF	X	\$26.30	=	\$131.50
Total	3368.0 Mbf				\$346,146.20 ÷ 199.0 acres = \$1,739.43/Acre

Unit RW

Douglas Fir	495.0 MBF	X	\$111.40	=	\$55,143.00
Western Hemlock	72.0 MBF	X	\$46.30	=	\$3,333.60
Red Alder	6.0 MBF	X	\$25.80	=	\$154.80
Total	573.0 Mbf				\$58,631.40 ÷ 6.0 acres = \$9,771.90/Acre

Unit RW2

Douglas Fir	211.0 MBF	X	\$111.40	=	\$23,505.40
Noble Fir	11.0 MBF	X	\$45.90	=	\$504.90
Bigleaf Maple	1.0 MBF	X	\$26.30	=	\$26.30
Total	223.0 Mbf				\$24,036.60 ÷ 2.0 acres = \$12,018.30/Acre

TABLE OF CONTENTS

SECTION	PAGE	DESCRIPTION
100	4-9	General
150	10-15	Road Plan and Detail Sheets
200	16-17	Clearing and Grubbing
300	17-20	Excavation and Embankment
400	20-23	Pipe Culverts
500	24	Renovation and Improvement of Existing Roads
600	25	Watering
700	25-26	Aggregate Base Course – Pitrun Rock
1000	26-30	Aggregate Base Course - Crushed Rock
1200	30-33	Aggregate Surface Course - Crushed Rock
1400	33-35	Slope Protection
1600	35-37	Quarry and Borrow Pit Development
1700	37-38	Erosion Control
1800	38-40	Soil Stabilization
2100	40-41	Roadside Brushing
2300	42-43	Slope Staking
2600	43-45	Hot Mix Asphalt Concrete Paving
2700	45	Barricades and Control Devices
	46-50	Road Plan Maps
	51	Earth Barricade, Waterdip, Drivable and Non-Drivable Waterbar Details
	52	Brushing Details
	53	Sediment Catch Basin Details
	54-65	Culvert List
	66	Culvert Band Details
	67	Culvert Installation Details
	67-78	Rock Volumes Totals

**U.S. DEPARTMENT OF THE INTERIOR
 Bureau of Land Management
 SALEM DISTRICT – OREGON
 TIMBER SALE CONTRACT
 ROAD SPECIFICATIONS**

Road Number	New Construction (Stations and Miles)	Improvement (Stations and Miles)	Renovation (Stations and Miles)
4-6-7.4	32+42 Sta. = 0.614 Miles		9+20 Sta. = 0.174 Miles
4-6-7.5	11+40 Sta. = 0.216 Miles		
4-6-18.1	9+28 Sta. = 0.176 Miles		
4-6-18.2	5+45 Sta. = 0.103 Miles		
4-7-1.2			48+65 Sta. = 0.921 Miles
4-7-1.4	1+21 Sta. = 0.023 Miles		34+27 Sta. = 0.649 Miles
4-7-11.2			67+43 Sta. = 1.277 Miles
4-7-12.0A			5+05 Sta. = 0.096 Miles
4-7-12.0B	7+13 Sta. = 0.135 Miles		7+65 Sta. = 0.145 Miles
4-7-12.1			17+16 Sta. = 0.325 Miles
4-7-12.4			2+64 Sta. = 0.050 Miles
4-7-12.5			3+60 Sta. = 0.068 Miles
4-7-12.6			1+43 Sta. = 0.027 Miles
4-7-12.8	3+88 Sta. = 0.073 Miles		
4-7-12.9	15+28 Sta. = 0.289 Miles		
4-7-12.10	3+85 Sta. = 0.073 Miles		
4-7-12.11	2+34 Sta. = 0.044 Miles		
4-7-12.12	9+10 Sta. = 0.172 Miles		
4-7-12.13	3+96 Sta. = 0.075 Miles		
4-7-13.0			7+81 Sta. = 0.148 Miles
4-7-13.1			4+15 Sta. = 0.079 Miles
4-7-13.2			16+70 Sta. = 0.316 Miles
4-7-13.4			3+70 Sta. = 0.070 Miles
4-7-13.5			4+90 Sta. = 0.093 Miles
4-7-13.6			29+83 Sta. = 0.565 Miles
4-7-13.7			6+73 Sta. = 0.127 Miles
4-7-13.9			5+88 Sta. = 0.111 Miles
4-7-13.10			1+58 Sta. = 0.030 Miles
4-7-13.11	4+73 Sta. = 0.090 Miles		
4-7-14.3			30+78 Sta. = 0.583 Miles
4-7-14.4			6+45 Sta. = 0.122 Miles
4-7-14.11			8+03 Sta. = 0.152 Miles
4-7-15.1			167+53 Sta. = 3.173 Miles
4-7-15.8			6+88 Sta. = 0.130 Miles

4-7-15.9			6+70 Sta. = 0.127 Miles
4-7-15.10		2+00 Sta. = 0.038 Miles	3+90 Sta. = 0.074 Miles
4-7-15.11	3+30 Sta. = 0.063 Miles		
4-7-23.3			3+55 Sta. = 0.067 Miles
4-7-23.4	3+65 Sta. = 0.069 Miles		
4-7-24.0			72+02 Sta. = 1.364 Miles
4-7-24.0B			20+10 Sta. = 0.381 Miles
4-7-24.1			16+05 Sta. = 0.304 Miles
4-7-24.2			8+61 Sta. = 0.163 Miles
4-7-27.2			40+71 Sta. = 0.771 Miles
4-7-36.0			293+46 Sta. = 5.558 Miles
5-7-3.0			2+17 Sta. = 0.041 Miles
5-7-11.0			2+80 Sta. = 0.053 Miles
5-7-11.1			5+35 Sta. = 0.101 Miles
5-7-11.2	9+85 Sta. = 0.187 Miles		
5-7-15.0			73+18 Sta. = 1.386 Miles
5-7-15.1			23+95 Sta. = 0.454 Miles
5-7-15.2			11+52 Sta. = 0.218 Miles
5-7-15.3	6+66 Sta. = 0.126 Miles		
5-7-15.4	9+38 Sta. = 0.178 Miles		
5-7-22.0			181+95 Sta. = 3.466 Miles

GENERAL – 100

101 - Pre-work Conference(s):

A pre-work conference will be held prior to the start of new construction, renovation, improvement, quarry development, and decommissioning operations. The Purchaser shall request the conference at least forty-eight (48) hours prior to the time it is to be held. The conference will be attended by the Purchaser and/or their representatives, subcontractors or their representatives and the Authorized Officer and/or their representatives.

The purpose of the prework conference will be to review the required work, exhibits and specifications, and to establish a work schedule and a list of the Purchaser's representatives and subcontractors.

102 - Definitions:

AASHTO - American Association of State Highway and Transportation Officials. Current editions of tests and specifications.

ACI - American Concrete Institute

Apparent Opening Size (AOS) - Number of the U.S. Bureau of Standard sieve (or its opening size in millimeters or inches) having openings closest in size to the diameter of uniform particles which will allow five (5) percent by weight to pass through the geotextile material when shaken in a prescribed manner. This is also referred to as Equivalent Opening Size (EOS).

ASTM - American Society for Testing and Materials.

Base Course - Surfacing structure consisting of crushed gravel or stone, crushed sandstone, pit-run rock, bank or river-run gravels, etc., to provide support and, in the event no surface course is placed, the running surface for traffic load.

BLM - Bureau of Land Management

Borrow - Excavated material required for embankments and other portions of the work.

Burst Strength - The resistance of a geotextile material to rupture from pressure applied at right angles to the plane of the geotextile material under specified conditions, usually expressed as the amount of pressure causing failure. Rupture or burst results from tensile failure of the geotextile material.

Culvert - A pipe, pipe-arch, arch, or box structure constructed of metal, concrete, plastic or wood which provides an opening under the roadway primarily for the conveyance of liquids, pedestrians or livestock.

Curve Widening - Widening required on inside of curves to accommodate long log and equipment hauling trucks.

Embankment - A structure of soil, aggregate, or rock material placed on a prepared ground surface and constructed to subgrade.

End Haul - Excavated material moved, other than by dozer, to an embankment or waste area to prevent side casting material outside of the road prism.

Excess Excavation - Material from the roadway in excess of that needed for construction of the designed roadway (waste).

Grading - Leveling to grade, shaping and smoothing of a road subgrade; the shaping of roadside ditches as to grade and contour. In some instances, includes smoothing of the cut bank.

Overhaul - Distance excavated material is transported in excess of the distance included in the cost for excavation.

Pioneer Road - Temporary construction access built along the route of the project.

Piping - The process by which soil particles are washed in or through pore spaces in drains and filters or poorly compacted fill/backfill material.

Plans - The approved drawings, or exact reproductions thereof which show the locations, character, dimensions, and details of the work to be done.

Purchaser - The individual, partnership, joint venture, or corporation contracting with the Government under the terms of a Timber Sale Contract and acting independently or through their, or its agents, employees, or contractors.

Reasonably Close Conformity - Compliance with reasonable and customary manufacturing and construction tolerances where working tolerances are not specified.

Roadbed - The graded portion of the road within top and side slopes, prepared as a foundation for the pavement structure and shoulders.

Road Centerline - The longitudinal center of a roadbed.

Road Improvement - Work done to an existing road which improves it over its original design standard.

Road Renovation - Work done to an existing road which restores it to its original design.

Roadway - The portion of a road within limits of construction. Usually from the toe of the fill slope to a point where the cut slope intersects natural ground line.
Synonym - road prism.

Scale - In quarrying, consists of the removal of loose or overhanging rock adhering to the solid face after a shot or a round of shots has been fired.

Scarification - The process of loosening or breaking up of the surface layer of soil or road, usually to a specified depth.

Shoulder - The portion of the roadbed contiguous with the traveled way designed for accommodation of stopped vehicles, safety, and lateral support of base and surface courses.

Slope ratio notation (horizontal: vertical) - Slope ratios for constructed cut and fill slopes are expressed as a ratio of horizontal units to vertical units.

Spalls - Flakes or chips of stone.

Specifications - A general term applied to all directions, provisions, and requirements pertaining to performance of the work.

Specific Gravity - The ratio of the density of a material to the density of water obtained by weighing known volumes of both items in air. A specific gravity less than one implies that the material will float.

Structures - Bridges, culverts, catch basins, retaining walls, underdrains, flumes, splash pads, downspouts, and other project features which may be involved in the work and not otherwise classified in these specifications.

Sub-base - Reinforcement of the subgrade with large particles of pit-run rock or crushed stone. Usually confined to roads having wet subgrades or subgrades with weak support characteristics.

Surface Course - Top layer of a road structure consisting of finely crushed gravels or asphalt designed to provide a smooth-running surface for traffic load.

Subgrade - The top surface of a roadbed upon which the traveled way and shoulders are constructed.

Timber - Standing trees, downed trees, or logs which can be measured in board feet.

Traveled Way - The portion of the roadbed used for the movement of vehicles, exclusive of shoulders.

Typical Cross Sections - Cross-sectional plane of a typical roadway; showing natural ground line and designed roadway in relation to cut and fill, through cut, and through fill.

Turnout - Extra widening of the roadbed at appropriate intervals on single-lane roads for passing purposes.

102a - Tests Used in These Specifications:

<u>AASHTO T 11</u>	Quantity of rock finer than No. 200 sieve.
<u>AASHTO T 27</u>	Sieve analysis of fine and coarse aggregate using sieves with square openings; gradation.
<u>AASHTO T 89</u>	Liquid limit of material passing the No. 40 sieve. Water content at which the soil passes from a plastic to a liquid state.
<u>AASHTO T 90</u>	Plastic limits and plasticity index of soil. a. Plastic limit - lowest water content at which the soil remains plastic. b. Plasticity index - range of water content, within which the material is in a plastic state. Numerical difference between the liquid and plastic limits of the soil.
<u>AASHTO T 96</u>	Resistance to abrasion of small size coarse aggregate by use of the Los Angeles machine.
<u>AASHTO T 99</u>	Relationship between soil moisture and density of soil. Method A - 4" mold, soil passing a No. 4 sieve 25 blows/layer & 3 layers. Method C - 4" mold, soil passing a 3/4-inch sieve 25 blows/layer & 3 layers. Method D - 6" mold, soil passing a 3/4-inch sieve. 56 blows/layer & 3 layers.
<u>AASHTO T 119</u>	Slump of hydraulic cement concrete.
<u>AASHTO T 152</u>	Air content of freshly mixed concrete.
<u>AASHTO T 166</u>	Specific Gravity of compacted Bituminous Mixtures.
<u>AASHTO T 176</u>	Shows relative portions of fine dust or claylike materials in soil or graded aggregate.
<u>AASHTO T 180</u>	(OSHD 106-71) moisture density relationship of soil same as AASHTO T 99 proctor but uses a 10-lb rammer & 18-in drop height.

<u>AASHTO T 191</u>	<u>Sand Cone.</u> Density of soil in place: For subgrade use 6-inch or 12-inch cone. For rock surfacing for 1-1/2-inch minus to 3-inch minus use 12-inch cone.
<u>AASHTO T 205</u>	<u>Rubber balloon.</u> Density of soil in place. Use for compacted or firmly bonded soil.
<u>AASHTO T 209</u>	Maximum Specific Gravity of Bituminous Paving Mixtures.
<u>AASHTO T 210</u>	Durability of aggregates based on resistance to produce fines.
<u>AASHTO T 224</u>	Correction for coarse particles in the soil.
<u>AASHTO T 238</u>	Density of Soil and Soil-Aggregate in place by nuclear methods.
<u>AASHTO T 248</u>	Reducing field samples of aggregate to testing size by mechanical splitter, quartering, or miniature stockpile sampling.
<u>ASTM D 4564</u>	Determination of relative density of cohesion less soils.
<u>DMSO (dimethyl sulfide)</u>	Determines volume of expanding clays in aggregates. Usually associated with marine basalts.

103 - Compaction equipment shall meet the following requirements:

103b - Sheepsfoot/Tamping rollers. A tamping roller unit shall consist of two (2) watertight metal drums mounted in frames in such manner as to be fully oscillating, together with a tractor having sufficient weight and power under actual working conditions to pull the roller drums at a minimum speed of two and a half (2.5) miles per hour. The drums shall be no less than sixty (60) inches in diameter and no less than fifty-four (54) inches in length, measured at the drum's surface, and shall be studded with tamping feet projecting not less than seven (7) inches from the face of the drums.

The distance between circumferential rows of tamper feet shall be such that the diagonal distance from any foot to the nearest foot in each adjacent row shall be not more than twelve (12) inches. The cross-sectional area of the face of each tamper foot, measured perpendicular to the axis of the stud, shall be not less than 5-1/2 square inches nor more than eight (8) square inches.

The weight of the tamping-roller unit shall be such as to exert a minimum pressure of two hundred fifty (250) pounds per square inch on the ground area in contact with the tamping feet, and the roller shall be so designed that the weight

may be increased to exert a pressure up to five hundred (500) pounds per square inch on the ground area in contact with the tamping feet.

The ground pressure shall be determined by dividing the total weight of the roller unit, not including the weight of the tractor, by the total cross-sectional area of the tamping feet in one (1) row of tamping feet parallel to the axis of the roller.

- 103f - Vibratory roller. The drum diameter shall be not less than forty-eight (48) inches, the drum width not less than fifty-eight (58) inches and have a turning radius of fifteen (15) feet or less. Vibration frequency shall be regulated in steps to 1400, 1500, and 1600 vibrations per minute (VPM), corresponding to engine speeds of 1575, 1690, and 1800 RPM. The centrifugal force developed shall be seven (7) tons at 1600 RPM. It shall be activated by a power unit of not less than twenty-five (25) horsepower. The vibratory roller shall be self-propelled or drawn by a vehicle of sufficient horsepower to enable the unit to travel through a loose layer of material at a speed ranging from 0.9 mile to 1.8 miles per hour, as directed by the Authorized Officer.

The towing vehicle and roller or self-propelled unit meeting the above requirements shall be considered a vibratory roller unit.

- 103g - Vibratory compactor. Vibratory compactors shall consist of multiple or gang-type compacting units or pads with a minimum variable width of two (2) feet. It shall be self-contained and capable of compacting material as required.
- 103h - Drum drive self-propelled vibratory grid roller. The unit shall consist of one cylindrical drum with a drum diameter of not less than fifty-six (56) inches, nor shall be more than sixty-six (66) inches and the drum width be eighty-four (84) inches. Vibration frequency shall be regulated in steps from 1200 to 1800 vibrations per minute (VPM), and the centrifugal force developed shall be at least 40,000 pounds at 1800 RPM. The vibratory grid roller shall be self-propelled and have a power unit of not less than 112 horsepower. The "grid" design shall be a herringbone or z-bar pattern around the circumference of the drum. The grid bars shall be one (1) inch in height and spaced not more than eight and one half (8-1/2) inches apart.
- 103i - Other. Compaction equipment approved by the Authorized Officer.

Road Number	Start Station or Milepost	End Station or Milepost	Total Length	Typical Cross Section	Min. Curve Radius	ROAD WIDTH		GRADIENT		SURFACING (*5)										Remarks
						Subgrade	Ditch	Max. Favorable	Max. Adverse	BASE COURSE					SURFACE COURSE					
										Min. Width	Comp. Depth	Surface Type (#3)	Grading Size (#3)	Number of Lifts	Min. Width	Comp. Depth	Surface Type (#3)	Grading Size (#3)	Number of Lifts	
4-6-7.4	0+00	9+20	9+20	5		16'	2'	--	--	--	--	ABC	D	--	--	ASC	C	--	Renovation. Re-establish ditchline as directed. Tie ditch on the left into the 4-7-36.0 ditchline @ Sta. 0+00. Road is to be renovated to design and slope stakes between Sta. 5+53 - 9+20 as marked and directed. Spread 35 CY 1-1/2"-0" Crushed Spot Rock as marked. Spread 55 CY 6" Jaw Run Base Rock as marked. Place 35 CY 1-1/2"-0" Crushed Rock as culvert bedding/backfill as marked. Remove existing tank trap @ Sta. 0+10. Construct and surface 1 junction apron as marked. Construct 1 waste area as marked. Construct 1 turnout/turnaround as marked. Construct ditchouts as marked and needed. Install 2 Sediment Catch Basins with Straw Bales as marked. Install 2 culverts & 1 downspout (1 with medium fill). Install 2 inlet markers.	
	9+20	41+62	32+42	5		16'	2'	18%	18%	--	--	ABC	D	--	--	ASC	C	--	New Construct. Road is to be constructed to design and slope stakes between Sta. 9+20 - 25+77 as marked and directed. Spread 100 CY 1-1/2"-0" Crushed Spot Rock as marked. Spread 130 CY 6" Jaw Run Base Rock as marked. Place 130 CY 1-1/2"-0" Crushed Rock as culvert bedding/backfill. Remove large stump @ Sta. 26+97 as directed. Construct ditchouts as marked and needed. Construct 2 turnout/roadside landing as marked. Construct 1 junction/curve between Sta. 39+27 - 41+62 as marked and directed. Construct a turnout as marked. Construct a waste area as marked. Install 7 culverts. Install 7 inlet markers.	
4-6-7.5	0+00	11+40	11+40	3		14'	0'	15%	15%	--	--	--	--	--	--	--	--	--	New Construct. Construct ditchouts as needed. Construct 1 turnout as marked. Construct 1 turnaround as marked. Construct 1 waste area as marked. Construct a landing (approx. 50' diameter) as marked. Excavate material to achieve desired alignment and grade between Sta. 1+50 - 3+10, & Sta. 7+40 - 8+04 as marked and Directed. Drift/haul excavated material as fill between Sta. 8+04 - 8+50 as marked and directed. Haul excess material to waste area as directed.	
4-6-18.1	0+00	5+12	5+12	5		14'	2'	14%	14%	--	--	ABC	D	--	--	ASC	C	--	New Construct. Construct ditchouts as marked and needed. Tie both ditches from through-cut ahead into the 4-7-36.0 ditchline @ Sta. 0+00. Spread 10 CY 1-1/2"-0" Crushed Spot Rock as marked. Spread 20 CY 6" Jaw Run Base Rock as marked. Construct 1 turnaround as marked. Construct and surface 1 junction apron as marked. Excavate material to achieve desired alignment and grade between Sta. 2+82 - 5+12 as marked and directed. Drift/haul material as fill between Sta. 1+20 - 2+82 as marked and directed.	
	5+12	9+28	4+16	3		14'	0'	14%	14%	--	--	--	--	--	--	--	--	--	New Construct. Construct ditchouts as needed. Construct 1 turnaround as marked. Construct a landing (approx. 50' diameter) as marked.	
4-6-18.2	0+00	5+45	5+45	3		14'	0'	8%	8%	--	--	--	--	--	--	--	--	--	New Construct. Construct ditchouts as needed. Construct 1 turnaround as marked. Construct a landing (approx. 50' diameter) as marked.	
4-7-1.2	0+00	48+65	48+65	6		14'	2'	--	--	12'	8"	ABC	A	1	--	ASC	C	--	Renovation. Portions of Road are seasonally restricted, refer to section 44. n. for dates renovation work may occur. Re-establish ditchline and haul material to WA as directed. Spread an 8" Lift 3"-0" Crushed Base Rock (approx. 2,161 CY) as directed. Spread 240 CY 6" Jaw Run Base Spot Rock as marked. Spread 100 CY 1-1/2"-0" Crushed Spot Rock as marked. Place 100 CY 1-1/2"-0" Crushed Rock as culvert bedding/backfill as marked. Place 5 CY Class 5 RipRap as outlet energy dissipater as marked. Remove existing waterbars as marked. Construct ditchouts as marked and needed. Clean buried inlet and outlet of existing CMP @ Sta. 46+47 as marked. Construct and surface 1 junction apron as marked. Construct 1 waste area as marked. Construct 1 turnaround/waste area as marked. Construct turnouts as marked. Construct a landing (approx. 50' diameter) as marked. Clean asphalt approach of debris as marked and directed. Construct drivable waterbar across trail to right to capture runoff and direct into ditchline @ MP 1+53 as marked and directed. Replace 7 culverts & 2 half-rounds (1 with medium fill) as marked. Install 2 downspouts. Install 11 inlet markers.	
4-7-1.4 Eastline Quarry Rd.	0.000	0.553	0.553	6		14'	2'	--	--	--	--	PRR & ABC	D	--	12'	4"	ASC	C&E	1	Renovation. Re-establish ditchline and haul material to WA as directed. Spread a 4" Lift 1-1/2"-0" Crushed Cap Rock (approx. 628 CY) as directed. Spread 230 CY 6" Jaw Run Base Spot Rock as marked. Spread 40 CY 1-1/2"-0" Crushed Spot Rock as marked. Place 165 CY 1-1/2"-0" Crushed Rock as culvert bedding/backfill as marked. Place 20 CY 3/4"-0" crushed cap rock over base rock for culvert replacement @ Sta. 0.00 as marked. Place 10 CY Pit-run as ditchline armor as marked. Place 10 CY Class 5 RipRap as inlet fill armor as marked. Place 60 CY Class 5 RipRap as outlet fill armor/energy dissipater as marked. Cut and replace/spread Bituminous surfacing over culvert replacement area at MP 0.000 (approx. 3' wide x 50' long (approx. 3.7 tons asphalt)) as directed. Haul cut asphalt to approved disposal site. Construct ditchouts as marked and needed. Construct and surface 1 junction apron as marked. Construct 1 turnout/roadside landing as marked. Construct 1 turnout as marked. Construct a 2' wide x 2' deep ditchline lined with Pit-Run between MP 0.358 - 0.370 as marked. Install 2 Sediment Catch Basins with Straw Bales as marked. Replace 7 culverts & Install 2 culverts (1 large fill; 1 medium fill) as marked. Install 6 inlet markers.
	0.553	0.649	0.096	4		14'	0'	--	--	--	--	ABC	D	--	12'	4"	ASC	C	1	Renovation. Spread an 4" Lift 1-1/2"-0" Crushed Cap Rock (approx. 116 CY) as directed. Construct ditchouts as needed.
	0.649	0.672	0.023	4		14'	0'	10%	10%	13'	9"	ABC	D	1	12'	4"	ASC	C	1	New Construct. Spread a 9" lift of 6" Jaw Run base rock (approx. 62 CY 6" Jaw Run) as directed. Spread a 4" Lift 1-1/2"-0" Crushed Cap Rock over Base Rock (approx. 24 CY) as directed. Spread 30 CY 1-1/2"-0" Crushed Spot Rock as marked. Spread 50 CY 6" Jaw Run Base Rock as marked. Construct ditchouts as needed. Construct 1 turnaround/roadside landing as marked. Construct and Surface a landing (approx. 50' diameter) as marked.

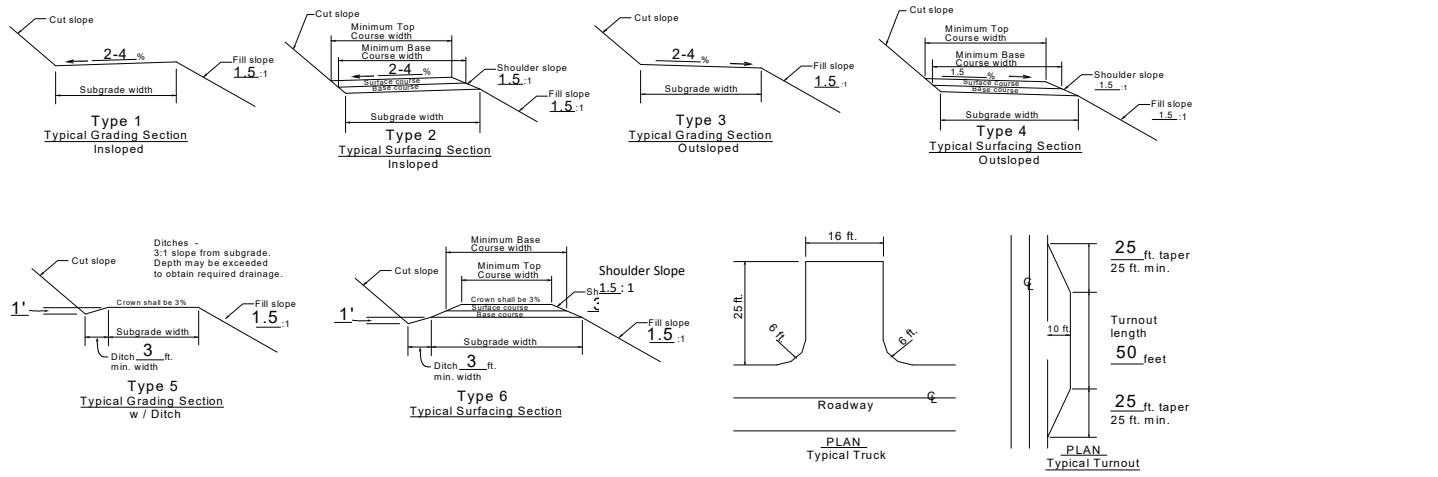

- *NOTES**
- Extra subgrade widths. Add to each shoulder: 1 ft. for fills of 1-6 ft. and 2 ft. for fills over 6 ft. Widen the inside shoulder of curves as follows: (See Road Plan Map, Exhibit C)
 - Backslopes. Materials: Solid rock 1/4:1, Soft rock and shale 1/2:1, Common 1:1. Slopes under 55% 1:1, Slopes over 55% 3/4:1. Cut slopes: 1/4:1, 1/2:1, 1:1. Fill slopes: 1.5:1, 1:1.2:1, 1:1.2:1.
 - Surface type. PRR - Pit run rock, GRR - Grid rolled rock, SRN - Screened rock, JRR - Jaw run rock, ABC - Aggr. base course, ASC - Aggr. surface course, WC - Wood chips. Grading: A - 3", B - 2", C - 3" jaw run (base course), D - 6" jaw run, E - 1 1/2"-0" (surface course), F - 3/4".
 - Turnouts. Width - 10 ft. in addition to subgrade width, or as shown on the plans. Located approximately as shown on the plans. Intervisible and not more than 750 ft. apart.
 - Surfacing. Turnouts, curve widening and road approach aprons shall be surfaced.
 - Clearing width. See Section 200.
 - As posted and painted for Right-of-Way.
 - Drainage. See Culvert List.
 - Compaction. See Sections 300 and 400.
- Note: Full bench construction is required on side slopes exceeding 60%.
- *Clearing Limits as posted on ground

Road Number	Start Station or Milepost	End Station or Milepost	Total Length	Typical Cross Section	Min. Curve Radius	ROAD WIDTH		GRADIENT		SURFACING (*5)										Remarks
						Subgrade	Ditch	Max. Favorable	Max. Adverse	BASE COURSE					SURFACE COURSE					
										Min. Width	Comp. Depth	Surface Type (#3)	Grading Size (#3)	Number of Lifts	Min. Width	Comp. Depth	Surface Type (#3)	Grading Size (#3)	Number of Lifts	
4-7-11.2 Bell Mtn. Ext. Rd.	0.000	1.277	1.277	6	14'	2'	--	--	--	--	PRR & ABC	D	--	--	--	ASC	C	--	Renovation. Portions of Road are seasonally restricted, refer to section 44.n for dates renovation work may occur. Re-establish ditchline and haul material to WA as directed. Spread 195 CY 1-1/2"-0" Crushed Spot Rock as marked. Spread 275 CY 6" Jaw Run Base Rock as marked. Place 260 CY 1-1/2"-0" Crushed Rock as culvert bedding/backfill as marked. Place 20 CY Pit-run as ditchline armor as marked. Place 55 CY Class 5 RipRap as inlet fill armor as marked. Place 115 CY Class 5 RipRap as outlet fill armor as marked. Place 40 CY Class 5 RipRap as outlet fill armor/energy dissipater as marked. Place 5 CY Class 5 RipRap as outlet energy dissipater as marked. Construct ditchouts as marked and needed. Construct and surface 1 junction apron as marked. Construct 1 turnout/turnaround as marked. Construct 3 waste areas as marked. Construct 1 turnout/turnaround as marked. Construct 4 turnouts as marked. Construct a landing (approx. 50' diameter) as marked. Construct a 2' wide x 2' deep ditchline lined with Pit-Run between MP 0.864 - 0.880 as marked. Install 13 Sediment Catch Basins with Straw Bales as marked. Install 2 culverts. Replace 12 culverts (4 medium, 2 large fills). Install 17 inlet markers.	
4-7-12.0A	0+00	5+05	5+05	6	14'	2'	--	--	--	ABC	D	--	--	--	ASC	C	--	Renovation. Re-establish ditchline and haul material to WA as directed. Spread 10 CY 1-1/2"-0" Crushed Spot Rock as marked. Spread 20 CY 6" Jaw Run Base Rock as marked. Construct ditchouts as marked and needed. Clean buried inlet and outlet of existing CMP @ Sta. 2+96 as marked. Construct and surface 1 junction apron as marked. Construct 1 turnout/roadside landing as marked. Construct 1 turnaround/roadside landing as marked. Construct a landing (approx. 50' diameter) as marked.		
4-7-12.0B	0+00	7+65	7+65	5	14'	2'	--	--	--	ABC	D	--	--	--	ASC	C	--	Renovation. Re-establish ditchline and haul material to WA as directed. Spread 25 CY 1-1/2"-0" Crushed Spot Rock as marked. Spread 35 CY 6" Jaw Run Base Rock as marked. Place 35 CY 1-1/2"-0" Crushed Rock as culvert bedding/backfill as marked. Construct ditchouts as marked and needed. Construct 1 turnout as marked. Install 2 culverts. Install 2 inlet markers.		
	7+65	14+78	7+13	5	14'	2'	14%	14%	--	ABC	D	--	--	--	ASC	C	--	9+90 & Sta. 10+50 - 13+64 as marked and Directed. Drift/haul excavated material as fill between Sta. 9+90 - 10+50 as marked and directed. Haul excess material to waste area as directed. Construct 1 turnout as marked. Construct 1 turnout/roadside landing as marked. Construct 1 turnaround as marked. Construct a landing (approx. 50' diameter) as marked. Install 1 culvert. Install 1 inlet marker.		
4-7-12.1	0+00	17+16	17+16	6	16'	2'	--	--	12'	8"	ABC	D & A	1	--	--	ASC	C & E	--	Renovation. Re-establish ditchline and haul material to WA as directed. Spread an 8" lift of 3"-0" Crushed Base Rock (approx. 851 CY) as directed. Spread 30 CY 1-1/2"-0" Crushed Spot Rock as marked. Spread 80 CY 6" Jaw Run Base Rock as marked. Place 35 CY 1-1/2"-0" Crushed Rock as culvert bedding/backfill as marked. Place 20 CY 3/4"-0" crushed cap rock over base rock for culvert replacement @ Sta. 0+22 as marked. Cut and replace/spread Bituminous surfacing over culvert replacement area at MP 0.000 (approx. 3' wide x 40' long (approx. 3.0 tons asphalt)) as directed. Haul cut asphalt to approved disposal site. Construct ditchouts as marked and needed. Construct and surface 1 junction apron as marked. Construct 1 turnout as marked. Construct a landing (approx. 50' diameter) as marked. Install 2 culverts. Install 1 inlet marker.	
4-7-12.4	0.000	0.050	0.050	4	14'	0'	--	--	--	--	--	--	--	--	ASC	C	--	Renovation. Spread 20 CY 1-1/2"-0" Crushed Spot Rock as marked. Construct ditchouts as needed. Construct a landing (approx. 50' diameter) as marked. DO NOT USE the stockpile of chip seal rock adjacent to road.		
4-7-12.5	0+00	3+60	3+60	4	14'	0'	--	--	--	ABC	D	--	12'	4"	ASC	C	1	Renovation. Spread a 4" lift of 1-1/2"-0" Crushed Rock (approx. 81 CY) as directed. Spread 60 CY 1-1/2"-0" Crushed Spot Rock as marked. Spread 90 CY 6" Jaw Run Base Rock as marked. Construct ditchouts as needed. Construct and surface 1 junction apron as marked. Construct a landing (approx. 70' diameter) as marked. Use material piled on left side of landing area as fill on the right side of landing area.		
4-7-12.6	0+00	1+43	1+43	4	14'	0'	--	--	13'	9"	ABC	D	1	12'	4"	ASC	C	1	Renovation. Spread a 9" lift of 6" Jaw Run base rock (approx. 75 CY) as directed. Spread a 4" Lift 1-1/2"-0" Crushed Cap Rock over Base Rock (approx. 31 CY) as directed. Spread 40 CY 1-1/2"-0" Crushed Spot Rock as marked. Spread 70 CY 6" Jaw Run Base Rock as marked. Construct ditchouts as needed. Construct and surface 1 junction apron as marked. Construct a landing (approx. 50' diameter) as marked.	
4-7-12.8	0+00	3+88	3+88	6	16'	2'	12%	12%	13'	9"	ABC	D	1	12'	4"	ASC	C	1	New Construct. Spread a 9" lift of 6" Jaw Run base rock (approx. 229 CY) as directed. Spread a 4" Lift 1-1/2"-0" Crushed Cap Rock over Base Rock (approx. 88 CY) as directed. Spread 40 CY 1-1/2"-0" Crushed Spot Rock as marked. Spread 70 CY 6" Jaw Run Base Rock as marked. Construct ditchouts as marked and needed. Excavate material to achieve desired alignment and grade between Sta. 0+19 - 1+00 as marked and Directed. Drift/haul excavated material as fill between Sta. 1+00 - 3+88 as marked and directed. Haul excess material to waste area as directed. Construct and surface 1 junction apron as marked. Construct a landing (approx. 50' diameter) as marked.	
4-7-12.9	0+00	15+28	15+28	6	16'	2'	18%	18%	13'	9"	ABC	D	1	12'	4"	ASC	C	1	New Construct. Spread a 9" lift of 6" Jaw Run base rock (approx. 900 CY) as directed. Spread a 4" Lift 1-1/2"-0" Crushed Cap Rock over Base Rock (approx. 345 CY) as directed. Spread 70 CY 1-1/2"-0" Crushed Spot Rock as marked. Spread 130 CY 6" Jaw Run Base Rock as marked. Place 45 CY 1-1/2"-0" Crushed Bedding/Backfill Rock as marked. Construct ditchouts as marked and needed. Excavate material to achieve desired alignment and grade between Sta. 2+33 - 3+79 as marked and Directed. Haul excess material to waste area as directed. Construct and surface 1 junction apron as marked. Construct 1 turnout/roadside landing as marked. Construct 1 turnout/waste area as marked. Construct 1 turnout/roadside landing as marked. Construct a landing (approx. 50' diameter) as marked. Install 3 culverts. Install 3 inlet markers.	
4-7-12.10	0+00	3+85	3+85	3	14'	0'	12%	12%	--	--	--	--	--	--	--	--	--	--	New Construct. Construct ditchouts as needed. Construct 1 junction as marked (excavate cut bank down to achieve a smooth transition). Construct 1 waste area as marked. Construct a landing (approx. 50' diameter) as marked.	
4-7-12.11	0+00	2+34	2+34	3	14'	0'	6%	6%	--	--	ABC	D	--	--	ASC	C	--	New Construct. Spread 10 CY 1-1/2"-0" Crushed Spot Rock as marked. Spread 20 CY 6" Jaw Run Base Rock as marked. Construct ditchouts as needed. Construct and surface 1 junction apron as marked. Construct 1 turnaround as marked. Construct a landing (approx. 50' diameter) as marked. Excavate material to achieve desired alignment and grade between Sta. 1+00 - 2+34 as marked and directed. Drift/haul material as fill between Sta. 0+60 - 1+00 as marked and directed. Haul excess material to waste area as directed.		
4-7-12.12	0+00	9+10	9+10	3	14'	0'	15%	15%	--	--	--	--	--	--	--	--	--	--	New Construct. Construct ditchouts as marked and needed. Construct 1 junction as marked. Construct 1 roadside landing/turnaround as marked. Construct a landing (approx. 50' diameter) as marked. Excavate and drift material to achieve desired grade between Sta. 0+00 - 2+50 & Sta. 4+77 - 8+43 as marked.	
4-7-12.13	0+00	3+96	3+96	4	14'	0'	7%	7%	12'	9"	ABC	D	1	--	--	ASC	C	--	New Construct. Spread a 9" lift of 6" Jaw Run base rock (approx. 204 CY) as directed. Spread 10 CY 1-1/2"-0" Crushed Spot Rock as marked. Spread 120 CY 6" Jaw Run Base Rock as marked. Construct ditchouts as marked and needed. Construct and surface 1 junction apron as marked. Construct 1 roadside landing as marked. Construct a landing (approx. 50' diameter) as marked. Trees on up-slope side of landing are critical to keep for guyline purposes. Cut and drift material to achieve desired alignment and grade between Sta. 1+54 - 2+76 as marked and directed.	
4-7-13.0	0.000	0.148	0.148	6	14'	2'	--	--	--	--	ABC	D	--	--	ASC	C	--	Renovation. Re-establish ditchline and haul material to WA as directed. Spread 20 CY 6" Jaw Run Base Spot Rock as marked. Spread 20 CY 1-1/2"-0" Crushed Spot Rock as marked. Remove existing waterbars as marked. Construct ditchouts as marked and needed. Construct and surface 1 junction apron as marked. Construct 1 turnout/roadside landing/turnaround as marked. Construct 1 turnaround as marked. Construct 1 roadside landing as marked.		

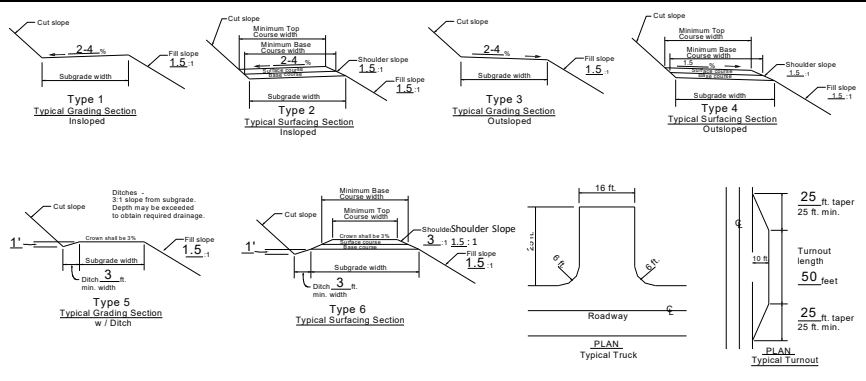

- *NOTES**
- Extra subgrade widths: Add to each shoulder: 1 ft. for fills of 1-6 ft. and 2 ft. for fills over 6 ft. Widen the inside shoulder of curves as follows: (See Road Plan Map, Exhibit C)
 - Backslopes: Materials: Solid rock 1:4:1, Soft rock and shale 1:2:1, Common Slopes under 55% 1:1, Slopes over 55% 3/4:1. Cut slopes: 1:4:1, Angle of repose 1:2:1. Fill slopes: 1:1:2:1, 1-1/2:1.
 - Surface type: PRR - Pit run rock, GRR - Grid rolled rock, GRN - Screened rock, JRR - Jaw run rock, ABC - Aggr. base course, ASC - Aggr. surface course, WC - Wood chips. Grading: A - 3" (base course), B - 2" (base course), C - 3" jaw run, D - 6" jaw run, E - 1 1/2"-0" (surface course), D - 1", E - 3/4".
 - Turnouts: Width - 10 ft. in addition to subgrade width, or as shown on the plans. Located approximately as shown on the plans. Intervisible and not more than 750 ft. apart.
 - Surfacing: Turnouts, curve widening and road approach aprons shall be surfaced.
 - Clearing width: 200. See Section.
 - As posted and painted for Right-of-Way.
 - Drainage: See Culvert List.
 - Compaction: See Sections 300 and 400.
- Note: Full bench construction is required on side slopes exceeding 60%.

*Clearing Limits as posted on ground

Road Number	Start Station or Milepost	End Station or Milepost	Total Length	Typical Cross Section	ROAD WIDTH		GRADIANT		SURFACING (*5)								Remarks
					Subgrade	Ditch	Max. Favorable	Max. Adverse	BASE COURSE				SURFACE COURSE				
									Min. Width	Comp. Depth	Surface Type (*3)	Grading Size (*3)	Number of Lifts	Min. Width	Comp. Depth	Surface Type (*3)	
4-7-13.1	0+00	4+15	4+15	6	14'	2'	--	--	--	--	--	--	ASC	C	--	Renovation. Re-establish ditchline and haul material to WA as directed. Spread 20 CY 1-1/2"-0" Crushed Spot Rock as marked. Construct ditchouts as marked and needed. Construct and surface 1 junction apron as marked. Construct 1 turnout/turnaround as marked. Construct a landing (approx. 50' diameter) as marked.	
4-7-13.2	0+00	14+30	14+30	6	14'	2'	--	--	--	ABC	D	--	ASC	C	--	Renovation. Re-establish ditchline and haul material to WA as directed. Spread 45 CY 1-1/2"-0" Crushed Spot Rock as marked. Spread 75 CY 6" Jaw Run Base Rock as marked. Place 35 CY 1-1/2"-0" Crushed Rock as culvert bedding/backfill as marked. Construct ditchouts as marked and needed. Construct and surface 2 junction aprons as marked. Construct 1 turnout as marked. Construct 1 turnaround as marked. Construct 1 waste area as marked. Install 1 culvert and replace 1 culvert. Install 2 inlet markers.	
	14+30	16+70	2+40	5	14'	2'	--	--	--	ABC	D	--	ASC	C	--	Renovation. Re-establish ditchline and haul material to WA as directed. Construct ditchouts as marked and needed. Construct a landing (approx. 50' diameter) as marked.	
4-7-13.4	0+00	3+70	3+70	5	16'	2'	--	--	--	ABC	D	--	ASC	C	--	Renovation. Re-establish ditchline and haul material to WA as directed. Spread 10 CY 1-1/2"-0" Crushed Spot Rock as marked. Spread 20 CY 6" Jaw Run Base Rock as marked. Construct ditchouts as marked and needed. Construct and surface 1 junction apron as marked. Construct 1 turnaround as marked. Construct a landing (approx. 100' diameter) as marked.	
4-7-13.5	0+00	4+90	4+90	6	14'	2'	--	--	--	ABC	D	--	ASC	C	--	Renovation. Re-establish ditchline and haul material to WA as directed. Spread 40 CY 1-1/2"-0" Crushed Spot Rock as marked. Spread 25 CY 6" Jaw Run Base Rock as marked. Place 25 CY 1-1/2"-0" Crushed Rock as culvert bedding/backfill as marked. Construct ditchouts as marked and needed. Construct and surface 1 junction apron as marked. Construct 1 turnaround as marked. Construct a landing (approx. 50' diameter) as marked. Replace 1 culvert.	
4-7-13.6	0.000	0.565	0.565	6	14'	2'	--	--	--	ABC	A	--	ASC	C	--	Renovation. Re-establish ditchline and haul material to WA as directed. Spread 20 CY 1-1/2"-0" Crushed Spot Rock as marked. Spread 70 CY 3"-0" Crushed Base Rock as marked. Construct ditchouts as marked and needed. Remove existing waterbars as marked. Clean buried inlet and outlet of existing CMP @ MP 0.003 as marked. Construct and surface 1 junction apron as marked. Construct 2 turnouts as marked. Construct 2 roadside landings as marked. Construct 1 turnout/turnaround/roadside landing as marked. Construct 1 turnaround/roadside landing as marked. Construct 1 turnaround as marked. Install 5 inlet markers.	
4-7-13.7	0+00	6+73	6+73	6	14'	2'	--	--	--	ABC	A & D	--	ASC	C	--	Renovation. Re-establish ditchline and haul material to WA as directed. Spread 35 CY 1-1/2"-0" Crushed Spot Rock as marked. Spread 20 CY 3"-0" Crushed Base Rock as marked. Spread 20 CY 6" Jaw Run Base Rock as marked. Place 20 CY 1-1/2"-0" Crushed Rock as Bedding/Backfill as marked. Construct ditchouts as marked and needed. Remove existing waterbars as marked. Construct and surface 1 junction apron as marked. Replace 1 culvert. Install 1 inlet marker.	
4-7-13.9	0+00	5+88	5+88	6	14'	2'	--	--	--	ABC	D	--	ASC	C	--	Renovation. Re-establish ditchline and haul material to WA as directed. Spread 70 CY 1-1/2"-0" Crushed Spot Rock as marked. Spread 115 CY 6" Jaw Run Base Rock as marked. Place 70 CY 1-1/2"-0" Crushed Rock as Bedding/Backfill as marked. Place 30 CY Class 5 RipRap @ inlet as Fill Armor as marked. Place 55 CY Class 5 RipRap @ outlet as Fill Armor as marked. Construct ditchouts as marked and needed. Construct and surface 1 junction apron as marked. Construct 2 sediment catch basins w/ bales as marked. Replace 3 culverts (1 medium fill, 2 large fills). Install 3 inlet markers.	
4-7-13.10	0+00	1+58	1+58	6	14'	2'	--	--	--	ABC	D	--	ASC	C	--	Renovation. Re-establish ditchline and haul material to WA as directed. Spread 50 CY 6" Jaw Run Base Rock as marked. Construct ditchouts as marked and needed. Construct 1 junction apron/turnaround as marked. Construct 1 waste area as marked. Construct a landing (approx. 50' diameter) as marked. Remove existing waste (approx. 200 CY) on existing landing footprint @ Sta. 1+38 and place in new waste area @ Sta. 0+47 as marked and directed.	
4-7-13.11	0+00	4+73	4+73	5	14'	2'	12%	12%	--	ABC	D	--	ASC	C	--	New Construct. Spread 25 CY 1-1/2"-0" Crushed Spot Rock as marked. Spread 40 CY 6" Jaw Run Base Rock as marked. Place 25 CY 1-1/2"-0" Crushed Rock as culvert bedding/backfill as marked. Construct ditch and ditchouts as marked and needed. Construct and surface 1 junction apron as marked. Construct 1 turnaround as marked. Construct a landing (approx. 50' diameter) as marked. Install 1 culvert in existing ditchline.	
4-7-14.3	0+00	30+78	30+78	6	14'	2'	--	--	--	ABC	D	--	ASC	C	--	Renovation. Spread 25 CY 1-1/2"-0" Crushed Spot Rock as marked. Spread 65 CY 6" Jaw Run Base Rock as marked. Place 15 CY 1-1/2"-0" Crushed Rock as Bedding/Backfill as marked. Re-establish ditchline and haul material to WA as directed. Construct ditchouts as marked and needed. Construct 1 roadside landing as marked. Construct 1 turnout/roadside landing as marked. Construct 1 turnaround/waste area as marked. Construct 1 turnaround/roadside landing as marked. Construct and surface 1 junction apron as marked. Replace 1 culvert. Install 1 downspout. Install 1 inlet marker.	
4-7-14.4	0+00	6+45	6+45	5	16'	2'	--	--	--	ABC	D	--	ASC	C	--	Renovation. Spread 10 CY 1-1/2"-0" Crushed Spot Rock as marked. Spread 20 CY 6" Jaw Run Base Rock as marked. Re-establish ditchline and haul material to WA as directed. Construct ditchouts as marked and needed. Construct 2 turnaround/roadside landings as marked. Construct and surface 1 junction apron as marked. Construct a landing (approx. 50' diameter) as marked. Install 1 inlet marker.	
4-7-14.11	0.000	0.152	0.152	6	14'	2'	--	--	--	ABC	D	--	ASC	C	--	Renovation. Spread 35 CY 1-1/2"-0" Crushed Spot Rock as marked. Spread 20 CY 6" Jaw Run Base Rock as marked. Place 20 CY 1-1/2"-0" Crushed Rock as Bedding/Backfill as marked. Re-establish ditchline and haul material to WA as directed. Construct ditchouts as marked and needed. Construct and surface 1 junction apron as marked. Construct a landing (approx. 50' diameter) as marked. Install 1 culvert.	
4-7-15.1	0.000	3.173	3.173	6	16'	2'	--	--	--	ABC	D	--	ASC	C	--	Renovation. Re-establish ditchline and haul material to WA as directed. Spread 595 CY 6" Jaw Run Base Spot Rock as marked and needed. Spread 885 CY 1-1/2"-0" Crushed Spot Rock as marked and needed. Place 345 CY 1-1/2"-0" Crushed Rock as culvert bedding/backfill as marked. Place 80 CY Class 5 RipRap as inlet fill armor as marked. Place 70 CY Class 5 RipRap as outlet fill armor as marked. Place 105 CY Class 5 RipRap as outlet stabilization wall/energy dissipater as marked. Place 90 CY Class 5 RipRap as outlet stabilization wall as marked. Re-use existing RipRap where applicable. Construct ditchouts as marked and needed. Clean buried inlet and outlet of existing CMP's @ MP 1.242, 1.677, & 2.438 as marked. Construct and surface 1 junction apron as marked. Construct 6 turnouts as marked. Construct 2 turnouts as marked. Construct 1 turnaround as marked. Construct 1 turnout/turnaround as marked. Install 15 Sediment Catch Basins with Straw Bales as marked. Repair/remove mud hole @ MP 0.010 with suitable on-site material as directed. Replace 14 culverts (3 medium fills, 3 large fills) & install 3 culverts (1 medium fill) as marked. Install 2 downspouts as marked. Install/replace 27 inlet markers.	
4-7-15.8	0+00	6+88	6+88	5	14'	2'	--	--	--	ABC	D	--	ASC	C	--	Renovation. Spread 25 CY 1-1/2"-0" Crushed Spot Rock as marked. Spread 40 CY 6" Jaw Run Base Rock as marked. Place 20 CY 1-1/2"-0" Crushed Rock as Bedding/Backfill as marked. Re-establish ditchline and haul material to WA as directed. Construct ditchouts as marked and needed. Construct and surface 1 junction apron as marked. Construct 1 turnout as marked. Construct 1 turnaround as marked. Construct a landing (approx. 50' diameter) as marked. Install 1 culvert.	
4-7-15.9	0+00	1+23	1+23	5	14'	2'	--	--	--	ABC	D	--	ASC	C	--	Renovation. Spread 25 CY 1-1/2"-0" Crushed Spot Rock as marked. Spread 40 CY 6" Jaw Run Base Rock as marked. Place 20 CY 1-1/2"-0" Crushed Rock as Bedding/Backfill as marked. Re-establish ditchline and haul material to WA as directed. Construct ditchouts as marked and needed. Construct and surface 1 junction apron as marked. Install 1 culvert. Re-establish OHV trail post harvesting operations between Sta. 0+00 - 1+23.	
	1+23	6+70	5+47	3	14'	0'	--	--	--	--	--	--	--	--	--	Renovation. Construct ditchouts as needed. Construct 1 turnout/turnaround as marked. Construct 1 waste area as marked. Construct a landing (approx. 50' diameter) as marked.	
4-7-15.10	0+00	3+90	3+90	6	16'	2'	--	--	13'	9"	ABC	D	2	12'	4"	1	Renovation. Spread a 9" lift of 6" Jaw Run base rock (approx. 202 CY) as directed. Spread a 4" Lift 1-1/2"-0" Crushed Cap Rock over Base Rock (approx. 78 CY) as directed. Spread 10 CY 1-1/2"-0" Crushed Spot Rock as marked. Spread 20 CY 6" Jaw Run Base Rock as marked. Construct ditchouts as marked and needed. Construct and surface 1 junction apron as marked. Construct 1 turnaround as marked. Remove waste @ Sta. 3+90 and haul to designated waste area as directed.
	3+90	5+90	2+00	6	16'	2'	12%	12%	13'	9"	ABC	D	2	12'	4"	1	Improvement. Spread a 9" lift of 6" Jaw Run base rock (approx. 112 CY) as directed. Spread a 4" Lift 1-1/2"-0" Crushed Cap Rock over Base Rock (approx. 43 CY) as directed. Construct ditchouts as marked and needed. Construct 1 waste area as marked. Construct a landing (approx. 50' diameter) as marked.
4-7-15.11	0+00	3+30	3+30	3	14'	0'	10%	10%	--	ABC	D	--	ASC	C	--	New Construct. Spread 10 CY 1-1/2"-0" Crushed Spot Rock as marked. Spread 20 CY 6" Jaw Run Base Rock as marked. Construct ditch and ditchouts as needed. Cut and drift material between Sta. 2+40 - 3+40 (using most material to construct end landing). Re-establish OHV trail post harvesting operations between Sta. 2+05. Construct and surface 1 junction apron as marked. Construct 1 turnaround as marked. Construct a landing (approx. 50' diameter) as marked.	

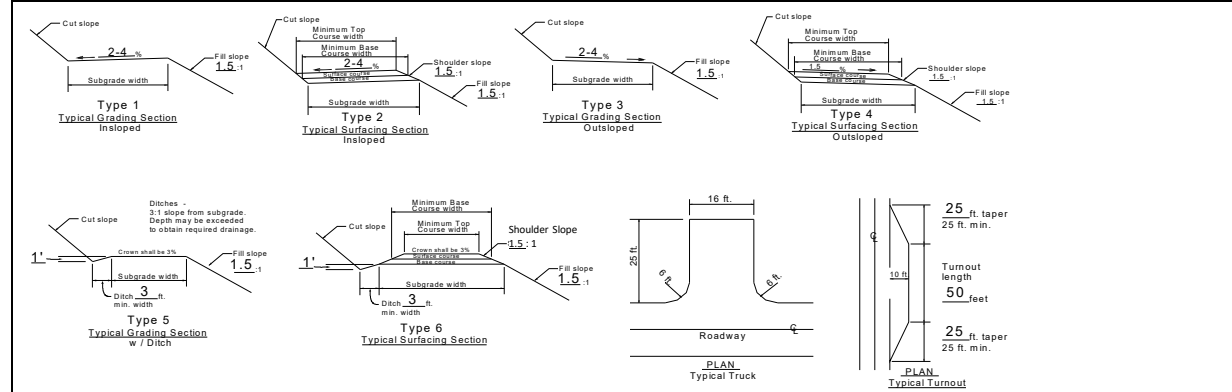

- *NOTES**
- Extra subgrade widths**
Add to each shoulder: 1 ft. for fills of 1-6 ft. and 2 ft. for fills over 6 ft. Widen the inside shoulder of curves as follows:
(See Road Plan Map, Exhibit C)
 - Backslopes**
Materials Cut slopes Fill slopes Angle of repose
Solid rock 1/4:1
Soft rock and shale 1/2:1
Common Slopes under 55% 1:1 1-1/2:1
Slopes over 55% 3/4:1 1-1/2:1
 - Surface type**
Materials Grading
PRR - Pit run rock A - 3" (base course)
GRR - Grid rolled rock B - 2" (base course)
SRN - Screened rock C - 3" jaw run (base course)
JRR - Jaw run rock D - 6" jaw run
ABC - Aggr. base course E - 1 1/2"-0"
ASC - Aggr. surface course D - 1"
WC - Wood chips E - 3/4" (surface course)
 - Turnouts**
Width - 10 ft. in addition to subgrade width, or as shown on the plans.
Located approximately as shown on the plans. Intervisible and not more than 750 ft. apart.
 - Surfacing**
Turnouts, curve widening and road approach aprons shall be surfaced.
 - Clearing width**
See Section 200
 - As posted and painted for Right-of-Way:**
 - Drainage**
See Culvert List
 - Compaction**
See Sections 300 and 400
- Note: Full bench construction is required on side slopes exceeding 50%.
- *Clearing Limits as posted on ground**

150: ROAD PLAN AND DETAIL SHEET

Road Number	Start Station or Milepost	End Station or Milepost	Total Length	Typical Cross Section	ROAD WIDTH		GRADIENT		SURFACING (*5)							Remarks			
					Subgrade	Ditch	Max. Favorable	Max. Adverse	Min. Width	Comp. Depth	Surface Type (*3)	Grading Size (*3)	Number of Lifts	Min. Width	Comp. Depth		Surface Type (*3)	Grading Size (*3)	Number of Lifts
4-7-23.3	0+00	3+55	3+55	3	16'	0'	--	--	--	--	ABC	D	--	--	--	ASC	C	--	Renovation. Spread 10 CY 1-1/2"-0" Crushed Spot Rock as marked. Spread 20 CY 6" Jaw Run Base Rock as marked. Construct ditchouts as needed. Construct and surface 1 junction apron as marked. Construct a turnaround as marked. Construct a landing (approx. 150' diameter) as marked.
4-7-23.4	0+00	2+15	2+15	4	15'	0'	--	--	12'	9"	ABC	D	1	--	--	ASC	C	--	New Construct. Spread a 9" lift of 6" Jaw Run Base rock (approx. 113 CY) as directed. Spread 10 CY 1-1/2"-0" Crushed Spot Rock as marked. Spread 20 CY 6" Jaw Run Base Rock as marked. Construct ditchouts as needed. Construct and surface 1 junction apron as marked. Construct 1 large stockpile/waste area as marked. Place quarry overburden in waste area @ Sta. 1+17 - 2+15. Use flat area between Sta. 1+17 - 2+15 as stockpile site during quarry development. Excavate existing bank to smooth grade transition @ Sta. 0+15 and haul material to waste area ahead.
	2+15	3+65	1+50	4	15'	0'	--	--	--	--	--	--	--	--	--	--	--	--	New Construct. Construct ditchouts as needed. Large excavation area for quarry development. Strip all organics and overburden (including rippable material of inferior quality) and haul to the waste area between Sta. 1+17 - 2+15 as directed.
4-7-24.0 Homestead Rd.	0.000	1.364	1.364	6	14'	2'	--	--	--	--	ABC	D	--	--	--	ASC	C	--	Renovation. Re-establish ditchline and haul material to WA as directed. Spread 235 CY 6" Jaw Run Base Spot Rock as marked and needed. Spread 180 CY 1-1/2"-0" Crushed Spot Rock as marked and needed. Spread 90 CY 3"-0" Crushed Base Rock as marked. Place 135 CY 1-1/2"-0" Crushed Rock as culvert bedding/backfill as marked. Place 40 CY Class 5 RipRap as outlet fill armor as marked. Place 10 CY Class 5 RipRap as outlet energy dissipater as marked. Remove existing waterbars and earthen barrier as marked. Construct ditchouts as marked and needed. Remove old gate post @ MP 0.050 as marked and dispose of in a legal manner. Clean buried inlet and outlet of existing CMP @ MP 0.169 as marked. Construct and surface 1 junction apron as marked. Construct 1 turnout/turnaround/waste area as marked. Construct 5 turnouts as marked. Construct 1 turnaround as marked. Construct a landing (approx. 50' diameter) as marked. Install 5 Sediment Catch Basins with Straw Bales as marked. Replace 5 culverts (1 large fill) & install 3 culverts as marked. Install 12 inlet markers.
4-7-24.0B	0+00	14+00	14+00	6	16'	2'	--	--	--	--	ABC	D	--	--	--	ABC	C	--	Renovation. Re-establish ditchline and haul material to WA as directed. Spread 60 CY 1-1/2"-0" Crushed Spot Rock as marked. Spread 80 CY 6" Jaw Run Base Rock as marked. Place 80 CY 1-1/2"-0" Crushed Bedding/Backfill Rock as marked. Place 10 CY Class 5 RipRap @ inlet as fill armor as marked. Place 10 CY Class 5 RipRap @ outlet as fill armor as marked. Remove existing waterbars as marked. Re-establish ditchline and haul material to WA as directed. Construct ditchouts as marked and needed. Construct 1 turnaround/roadside landing as marked. Construct 1 turnout/roadside landing as marked. Construct 1 waste area as marked. Construct 2 sediment catch basins with straw bales as marked. Install 4 culverts. Install 4 inlet markers.
	14+00	15+62	1+62	4	16'	0'	--	--	--	--	--	--	--	--	--	--	--	--	Renovation. Construct ditchouts as needed. Excavate and blend junction point at Sta. 14+00 so all roads have smooth grade transition.
	15+62	20+10	4+48	6	16'	2'	--	--	--	--	ABC	D	--	--	--	ASC	C	--	Renovation. Re-establish ditchline and haul material to WA as directed. Spread 15 CY 1-1/2"-0" Crushed Spot Rock as marked. Spread 20 CY 6" Jaw Run Base Rock as marked. Place 20 CY 1-1/2"-0" Crushed Bedding/Backfill Rock as marked. Remove existing waterbars as marked. Re-establish ditchline and haul material to WA as directed. Construct ditchouts as marked and needed. Construct 1 roadside landing as marked. Construct 1 turnaround/waste area as marked. Install 1 culvert. Install 1 inlet marker.
4-7-24.1	0.000	0.304	0.304	6	14'	2'	--	--	--	--	ABC	D	--	--	--	ASC	C	--	Renovation. Re-establish ditchline and haul material to WA as directed. Spread 60 CY 1-1/2"-0" Crushed Spot Rock as marked and needed. Spread 65 CY 6" Jaw Run Base Rock as marked. Place 65 CY 1-1/2"-0" Crushed Bedding/Backfill Rock as marked. Place 10 CY Class 5 RipRap as outlet fill armor as marked. Construct ditchouts as marked and needed. Construct 1 sediment catch basin with straw bale as marked. Install 1 culvert & replace 2 culverts (1 medium fill). Install 2 inlet markers. Construct a lead-off ditch from culvert outlet @ MP. 0.000 as directed.
4-7-24.2	0.000	0.163	0.163	6	14'	2'	--	--	--	--	ABC	D	--	--	--	ASC	C	--	Renovation. Re-establish ditchline and haul material to WA as directed. Spread 10 CY 1-1/2"-0" Crushed Spot Rock as marked and needed. Spread 30 CY 6" Jaw Run Base Rock as marked. Construct ditchouts as marked and needed. Construct and surface 1 junction apron as marked. Construct a landing (approx. 100' diameter) as marked.
4-7-27.2	0.000	0.676	0.676	6	16'	2'	--	--	--	--	ABC	D	--	13'	--	ASC	C	1	Renovation. Re-establish ditchline and haul material to WA as directed. Spread a 4" Lift 1-1/2"-0" Crushed Cap Rock over Base Rock (approx. 871 CY) as directed. Spread 30 CY 1-1/2"-0" Crushed Spot Rock as marked. Spread 110 CY 6" Jaw Run Base Rock as marked. Place 80 CY 1-1/2"-0" Crushed Bedding/Backfill Rock as marked. Place 15 CY Pit-Run as ditchline armor as marked. Place 10 CY Class 5 RipRap @ outlet as fill armor as marked. Place 25 CY Class 5 RipRap @ outlet as fill armor/energy dissipater as marked. Re-use existing RipRap as fill armor as marked. Construct ditchouts as marked and needed. Construct a 2' wide x 2' deep ditchline lined with Pit-Run between MP 0.293 - 0.325 as marked. Construct and surface 1 junction apron as marked. Construct 5 sediment catch basins with straw bales as marked. Install 1 culvert & replace 3 culverts (1 medium fill). Install 1 downspout. Install 7 inlet markers.
	0.676	0.771	0.095	6	16'	2'	--	--	14'	9"	ABC	D	1	13'	--	ASC	C	1	Renovation. Re-establish ditchline and haul material to WA as directed. Spread a 9" lift of 6" Jaw Run Base rock (approx. 306 CY) as directed. Spread a 4" Lift 1-1/2"-0" Crushed Cap Rock over Base Rock (approx. 122 CY) as directed. Place 20 CY 1-1/2"-0" Crushed Bedding/Backfill Rock as marked. Construct ditchouts as marked and needed. Whip Up Flats Quarry Floor (between MP 0.755 - 0.771) to be developed by removing all organics and material to level area. Existing RipRap may be utilized as project rock. Replace 1 culvert. Install 1 inlet marker.
4-7-36.0 Willamina Cr Rd	0.000	0.466	0.466	6	16'	2'	--	--	--	--	ABC & PRR	D	--	--	--	ASC	C	--	Renovation. Re-establish ditchline and haul material to WA as directed. Spread 90 CY 1-1/2"-0" Crushed Spot Rock as marked and needed. Spread 15 CY 6" Jaw Run Base Rock as needed. Place 40 CY Pit-Run as ditchline armor as marked. Place 5 CY Class 5 RipRap @ inlet as fill armor as marked. Construct ditchouts as marked and needed. Possible buried Utilities, Locates shall be done before any excavation work. Construct 3 turnouts as marked. Construct a 2' wide x 2' deep ditchline lined with Pit-Run between MP 0.252 - 0.348 as marked. Construct 4 junction aprons as marked. Construct 4 sediment catch basins with straw bales as marked. Install 4 inlet markers.
	0.466	0.799	0.333	6	16'	2'	--	--	--	--	ABC	D	--	14'	4"	ASC	C	1	Renovation. Re-establish ditchline and haul material to WA as directed. Spread a 4" Lift 1-1/2"-0" Crushed Cap Rock over Base Rock (approx. 424 CY) as directed. Spread 30 CY 6" Jaw Run Base Rock as marked and needed. Place 20 CY 1-1/2"-0" Crushed Bedding/Backfill Rock as marked. Construct ditchouts as marked and needed. Construct 1 sediment catch basin with bale as marked. Clean inlet and outlet of existing culvert between MP 0.695 - 0.735 as marked to allow for proper drainage. Install 1 culvert (medium fill). Install 6 inlet markers.
	0.799	0.995	0.196	6	16'	2'	--	--	--	--	ABC	D	--	--	--	--	--	--	Renovation. Re-establish ditchline and haul material to WA as directed. Spread 20 CY 1-1/2"-0" Crushed Spot Rock as needed. Spread 5 CY 6" Jaw Run Base Rock as needed. Construct ditchouts as marked and needed. Construct 1 turnout as marked. Construct 1 sediment catch basin with straw bale as marked. Install 1 inlet marker.
	0.995	1.039	0.044	6	16'	2'	--	--	--	--	ABC	D	--	14'	4"	ASC	C	1	Renovation. Re-establish ditchline and haul material to WA as directed. Spread a 4" Lift 1-1/2"-0" Crushed Cap Rock over Base Rock (approx. 56 CY) as directed. Construct ditchouts as marked and needed. Construct 1 sediment catch basin with bale as marked. Install 2 inlet markers.
	1.039	1.119	0.080	6	16'	2'	--	--	--	--	ABC	D	--	--	--	ASC	C	--	Renovation. Re-establish ditchline and haul material to WA as directed. Spread 25 CY 1-1/2"-0" Crushed Spot Rock as marked and needed. Spread 20 CY 6" Jaw Run Base Rock as marked. Place 20 CY 1-1/2"-0" Crushed Bedding/Backfill Rock as marked. Construct ditchouts as marked and needed. Construct 1 turnout as marked. Excavate and haul pre-existing slide material in cut bank to designated waste area (approx. 100 CY) as marked. Install 1 culvert. Install 1 downspout. Install 2 inlet markers.
	1.119	1.155	0.036	6	16'	2'	--	--	--	--	ABC	D	--	14'	4"	ASC	C	1	Renovation. Re-establish ditchline and haul material to WA as directed. Spread a 4" Lift 1-1/2"-0" Crushed Cap Rock over Base Rock (approx. 47 CY) as directed. Place 60 CY Class 5 RipRap @ outlet as fill armor/stabilization wall as marked. Construct ditchouts as marked and needed. Construct 2 sediment catch basins with bales as marked.
	1.155	1.247	0.092	6	16'	2'	--	--	--	--	ABC	D	--	--	--	ASC	C	--	Renovation. Re-establish ditchline and haul material to WA as directed. Spread 30 CY 1-1/2"-0" Crushed Spot Rock as marked and needed. Spread 20 CY 6" Jaw Run Base Rock as marked. Place 20 CY 1-1/2"-0" Crushed Bedding/Backfill Rock as marked. Construct ditchouts as marked and needed. Install 1 culvert. Install 1 downspout. Install 1 inlet marker.
	1.247	1.452	0.205	6	16'	2'	--	--	--	--	ABC & PRR	D	--	14'	4"	ASC	C	1	Renovation. Re-establish ditchline and haul material to WA as directed. Spread a 4" Lift 1-1/2"-0" Crushed Cap Rock over Base Rock (approx. 261 CY) as directed. Spread 50 CY 6" Jaw Run Base Rock as marked and needed. Place 40 CY 1-1/2"-0" Crushed Bedding/Backfill as marked. Place 10 CY Pit-Run as ditchline armor as marked. Construct ditchouts as marked and needed. Construct a 2' wide x 2' deep ditchline lined with Pit-Run between MP 1.394 - 1.421 as marked. Construct 1 sediment catch basin with bale as marked. Install 2 culverts (1 medium fill). Install 6 inlet markers.

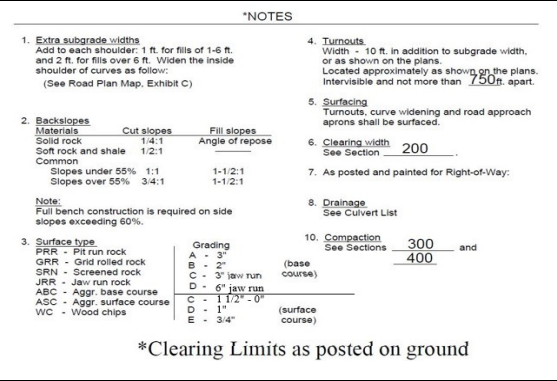
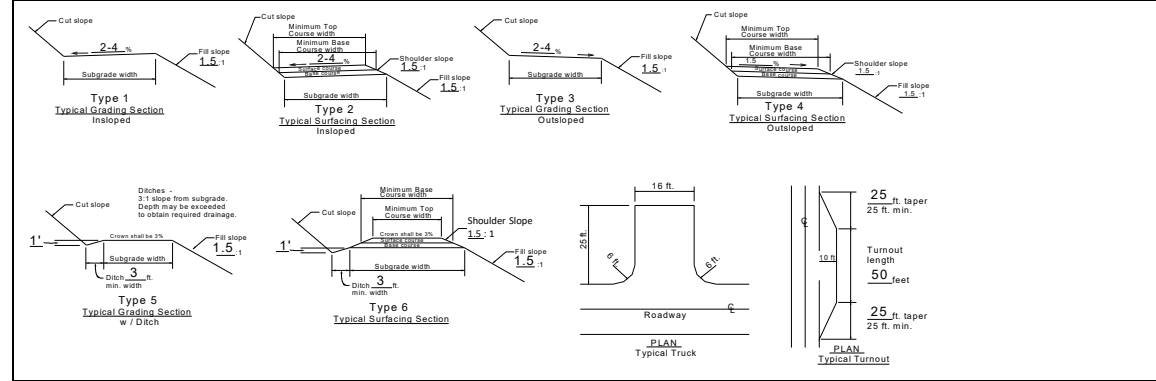

*NOTES

- Extra subgrade widths
Add to each shoulder: 1 ft. for fills of 1-6 ft. and 2 ft. for fills over 6 ft. Widen the inside shoulder of curves as follows:
(See Road Plan Map, Exhibit C)
 - Backslopes
Materials Cut slopes Fill slopes
Solid rock 1.4:1 Angle of repose
Soft rock and shale 1:2:1
Common
Slopes under 55% 1:1 1-1/2:1
Slopes over 55% 3:4:1 1-1/2:1
 - Surface type
PRR - Pit run rock
GRR - Grind rolled rock
SRN - Screened rock
JRR - Jaw run rock
ABC - Aggr. base course
ASC - Aggr. surface course
WC - Wood chips
Grading
A - 3"
B - 2"
C - 3" jaw run
D - 6" jaw run
E - 1 1/2" - 0"
D - 1"
E - 3/4" (surface course)
 - Turnouts
Width - 10 ft. in addition to subgrade width, or as shown on the plans.
Located approximately as shown on the plans.
Intervisible and not more than 750ft. apart.
 - Surfacing
Turnouts, curve widening and road approach aprons shall be surfaced.
 - Clearing width
See Section 200
 - As posted and painted for Right-of-Way:
 - Drainage
See Culvert List
 - Compaction
See Sections 300 and 400
- *Clearing Limits as posted on ground

Road Number	Start Station or Milepost	End Station or Milepost	Total Length	Typical Cross Section	Min. Curve Radius	ROAD WIDTH		GRADIENT		SURFACING (*5)											Remarks
						Subgrade	Ditch	Max. Favorable	Max. Adverse	BASE COURSE					SURFACE COURSE						
										Min. Width	Comp. Depth	Surface Type (*3)	Grading Size (*3)	Number of Lifts	Min. Width	Comp. Depth	Surface Type (*3)	Grading Size (*3)	Number of Lifts		
4-7-36.0 Willamina Cr Rd (cont)	1.452	2.030	0.578	6	16'	2'	--	--	--	--	ABC	D	--	--	--	ASC	C	--	Renovation. Re-establish ditchline and haul material to WA as directed. Spread 160 CY 1-1/2"-0" Crushed Spot Rock as marked and needed. Spread 75 CY 6" Jaw Run Base Rock as marked and needed. Construct ditchouts as marked and needed. Clean buried inlet of CPP @ MP 1.828 as marked. Construct 3 turnout as marked. Between MP 1.872 - 1.901, shift centerline of road to the left 4' and widen road by excavating into cut bank and hauling excavated material to designated waste area as directed (chiseling of rock may be required). Install 3 inlet markers.		
	2.030	2.116	0.086	6	16'	2'	--	--	--	ABC	D	--	14'	4"	ASC	C	1	Renovation. Re-establish ditchline and haul material to WA as directed. Spread a 4" Lift 1-1/2"-0" Crushed Cap Rock over Base Rock (approx. 109 CY) as directed. Construct ditchouts as marked and needed. Construct 2 sediment catch basins with bales as marked.			
	2.116	2.357	0.241	6	16'	2'	--	--	--	ABC	D	--	--	--	ASC	C	--	Renovation. Re-establish ditchline and haul material to WA as directed. Spread 60 CY 1-1/2"-0" Crushed Spot Rock as marked and needed. Spread 50 CY 6" Jaw Run Base Rock as marked and needed. Place 45 CY 1-1/2"-0" Crushed Bedding/Backfill as marked. Place 10 CY Class 5 RipRap as outlet fill armor as marked. Re-use existing RipRap as needed. Construct ditchouts as marked and needed. Construct 1 turnout as marked. Install 1 culvert (medium fill). Install 1 down spout. Replace 1 culvert (medium fill). Install 2 inlet markers.			
	2.357	2.433	0.076	6	16'	2'	--	--	--	ABC	D	--	14'	4"	ASC	C	1	Renovation. Re-establish ditchline and haul material to WA as directed. Spread a 4" Lift 1-1/2"-0" Crushed Cap Rock over Base Rock (approx. 97 CY) as directed. Spread 70 CY 6" Jaw Run Base Rock as marked. Place 20 CY 1-1/2"-0" Crushed Bedding/Backfill as marked. Place 75 CY Class 5 RipRap as outlet stabilization wall as marked. Construct ditchouts as marked and needed. Between MP 2.357 - 2.368, shift centerline of road to the left 3' and widen road by excavating into cut bank and hauling excavated material to designated waste area as directed. Excavate road down and construct a 6' side bench to hold RipRap for stabilization wall @ MP 2.375, as marked and directed. Repair slope before attaching downspouts to culvert @ MP 2.375 as directed. Replace 1 culvert (medium fill). Install 1 downspout. Install 1 inlet marker.			
	2.433	5.357	2.924	6	16'	2'	--	--	--	ABC	D	--	--	--	ASC	C	--	Renovation. Re-establish ditchline and haul material to WA as directed. Spread 590 CY 6" Jaw Run Base Spot Rock as marked and needed. Spread 755 CY 1-1/2"-0" Crushed Spot Rock as marked and needed. Place 230 CY 1-1/2"-0" Crushed Rock as culvert bedding/backfill as marked. Place 10 CY Class 5 RipRap as inlet fill armor as marked. Place 420 CY Class 5 RipRap as outlet/energy stabilization wall/energy dissipater as marked. Construct ditchouts as marked and needed. Clean and repair inlet of existing CMP @ MP 3.759 as marked. Construct 1 waste area as marked. Construct 2 roadside landings as marked. Construct 5 turnouts as marked. Construct 1 turnout as marked. Between MP 2.772 - 2.831, shift centerline of road to the left 4' and widen road by excavating into cut bank and hauling excavated material to designated waste area as directed. Between MP 2.786 - 2.798, construct a bench at toe of fill slope for RipRap placement as marked and directed. Between MP 3.164 - 3.232, shift centerline of road to the left 6' and widen road by excavating into cut bank and hauling excavated material to designated waste area as directed. At MP 3.512, Clean organics from fill slope and reshape as marked and directed. Excavate gradient of ditchline down to re-establish flow to existing culvert @ MP 3.874 as directed. Excavate and obliterate rogue OHV trails to the right and left @ MP 5.024 and use as waste area as marked. Re-establish ditchline in OHV disturbed area @ MP 5.007 as directed. Pile ditchline waste in undesignated OHV trails to the left and right as needed. Stabilization wall will also act as energy dissipater for Culvert @ MP 2.798 (place culvert on top of stabilization wall as directed). Install 15 Sediment Catch Basins with Straw Bales as marked. Place 2 straw bales in ditchlines leading to inlet of existing pipe @ MP 3.715 as marked and directed. Replace 5 culverts (1 medium fill). Install 5 culverts as marked. Install 3 downspouts. Install 3 inlet markers.			
	5.357	5.558	0.201	5	14'	2'	--	--	--	ABC	D	--	--	--	ASC	C	--	Renovation. Re-establish ditchline and haul material to WA as directed. Spread 75 CY 6" Jaw Run Base Spot Rock as marked and needed. Spread 70 CY 1-1/2"-0" Crushed Spot Rock as marked and needed. Place 70 CY 1-1/2"-0" Crushed Rock as culvert bedding/backfill as marked. Place 10 CY Class 5 RipRap as inlet fill armor as marked. Place 20 CY Class 5 RipRap as outlet fill armor as marked. Remove existing waterbars and earthen barrier as marked. Construct ditchouts as marked and needed. Construct 1 roadside landing as marked. Install 1 Sediment Catch Basin with Straw Bale as marked. Remove existing CMP and backfill with suitable local material before installation of new culvert @ MP 5.402, as marked. Install 4 culverts. Install 4 downspouts. Install 4 inlet markers.			
5-7-3.0	0+00	2+17	2+17	6	15'	2'	--	--	12'	9"	ABC	D	1	--	ABC	C	--	Renovation. Re-establish ditchline and haul material to WA as directed. Spread a 9" Lift of 6" Jaw Run Rock (approx. 110 CY) as marked. Spread 10 CY 1-1/2"-0" Crushed Spot Rock as marked. Spread 20 CY 6" Jaw Run Base Rock as marked. Construct ditchouts as marked and needed. Construct and surface 1 junction apron as marked. Construct 1 driveway waterbar as marked.			
5-7-11.0	0+00	2+80	2+80	5	14'	2'	--	--	--	ABC	D	--	--	--	ASC	C	--	Renovation. Re-establish ditchline and haul material to WA as directed. Spread 10 CY 1-1/2"-0" Crushed Spot Rock as marked. Spread 20 CY 6" Jaw Run Base Rock as marked. Construct ditchouts as marked and needed. Construct and surface 1 junction apron as marked. Construct a landing (approx. 50' diameter) as marked.			
5-7-11.1	0+00	5+35	5+35	5	14'	2'	--	--	--	ABC	D	--	--	--	ASC	C	--	Renovation. Re-establish ditchline and haul material to WA as directed. Spread 10 CY 1-1/2"-0" Crushed Spot Rock as marked. Spread 20 CY 6" Jaw Run Base Rock as marked. Construct ditchouts as marked and needed. Shift road prism slightly to the right to correct horizontal alignment @ Sta. 2+39 as marked and directed. Construct and surface 1 junction apron as marked. Construct 1 turnout/roadside landing as marked.			
5-7-11.2	0+00	9+85	9+85	3	14'	0'	16%	16%	--	--	--	--	--	--	--	--	--	New Construct. Construct ditch and ditchouts in through-cuts as needed. Excavate material to achieve desired alignment and grade between Sta. 1+80 - 5+70 as marked and directed. Drift/haul material as fill between Sta. 5+90 - 6+50 as marked and directed. Excavate material to achieve desired alignment and grade between Sta. 6+50 - 8+40 as marked and directed. Drift/haul material as fill for road between Sta. 8+40 - 9+85 & Landing Construction as marked and directed. Construct 1 turnout as marked. Construct 1 turnout/roadside landing as marked. Construct a rectangular landing (approx. 40' x 75') as marked.			
5-7-15.0	0.000	1.091	1.091	6	14'	2'	--	--	--	ABC	D	--	--	--	ASC	C	--	Renovation. Portions of Road are seasonally restricted, refer to section 44.n, for dates renovation work may occur. Re-establish ditchline and haul material to WA as directed. Spread 185 CY 1-1/2"-0" Crushed Spot Rock as marked. Spread 420 CY 6" Jaw Run Base Rock as marked. Place 200 CY 1-1/2"-0" Crushed Bedding/Backfill Rock as marked. Place 20 CY Class 5 RipRap @ outlet as fill armor as marked. Construct ditchouts as marked and needed. Construct and surface 1 junction apron as marked. Construct 2 turnouts/roadside landings as marked. Construct 1 turnout/roadside landing as marked. Construct 1 waste area as marked. Construct 1 stockpile site/waste area as marked. Construct 1 turnout as marked. At MP 0.000, remove two culverts (one across the 5-7-22.0 and one across the 5-7-15.0), backfill with local suitable material, and wrap ditchline on the left into ditchline of the 5-7-22.0 as marked and directed. Install new CPP @ MP 0.000 diagonally across the 5-7-22.0 & wrap ditchline on the left into newly installed CPP as marked. Repair road subgrade @ MP 1.091 by scarifying area of large mudhole and filling with suitable material before placing Base Rock as marked and directed. Install 1 culvert & replace 13 culverts (1 small & 1 medium fill). Install 13 inlet markers.			
	1.091	1.386	0.295	5	14'	2'	--	--	--	ABC	D	--	--	--	ASC	C	--	Renovation. Spread 20 CY 1-1/2"-0" Crushed Spot Rock as marked. Spread 25 CY 6" Jaw Run Base Rock as marked. Place 25 CY 1-1/2"-0" Crushed Bedding/Backfill Rock as marked. Construct ditchouts as marked and needed. At MP 1.241, widen outside of curve to increase curve radius and allow for curve widening width as marked and directed. Excavate material to achieve desired grade between MP 1.272 - 1.331 as marked and directed. Construct 2 turnarounds as marked. Construct a landing (approx. 100' diameter) as marked. Install 2 culverts. Install 2 inlet markers.			
5-7-15.1	0+00	23+95	23+95	3	14'	0'	--	--	--	ABC	D	--	--	--	ASC	C	--	Renovation. Re-establish ditchline and haul material to waste area as directed. Spread 10 CY 1-1/2"-0" Crushed Spot Rock as marked. Spread 20 CY 6" Jaw Run Base Rock as marked. Construct ditchouts as needed. Construct and surface 1 junction apron as marked. Construct 2 turnouts as marked. Construct 1 turnout as marked. Construct 2 turnarounds/roadside landings as marked. Construct 1 waste area as marked. Construct a landing (approx. 50' diameter) as marked.			
5-7-15.2	0+00	11+52	11+52	5	14'	2'	--	--	--	ABC	D	--	--	--	ASC	C	--	Renovation. Re-establish ditchline and haul material to WA as directed. Spread 10 CY 1-1/2"-0" Crushed Spot Rock as marked. Spread 20 CY 6" Jaw Run Base Rock as marked. Construct ditchouts as marked and needed. Construct and surface 1 junction apron as marked. Construct 1 turnout as marked. Construct a landing (approx. 50' diameter) as marked. At Station 0+00, wrap ditchline into culvert at MP 1.111 of the 5-7-22.0 as marked and directed.			
5-7-15.3	0+00	6+66	6+66	3	14'	0'	10%	10%	--	ABC	D	--	--	--	ASC	C	--	New Construct. Spread 10 CY 1-1/2"-0" Crushed Spot Rock as marked. Spread 20 CY 6" Jaw Run Base Rock as marked. Construct ditchouts as needed. Caution needed to avoid survey marker to the right @ Sta. 2+56 as marked. Construct and surface 1 junction apron as marked. Construct a landing (approx. 50' diameter) as marked.			
5-7-15.4	0+00	9+38	9+38	3	14'	0'	12%	12%	--	ABC	D	--	--	--	ASC	C	--	New Construct. Spread 10 CY 1-1/2"-0" Crushed Spot Rock as marked. Spread 20 CY 6" Jaw Run Base Rock as marked. Construct ditchouts as needed. Construct and surface 1 junction apron as marked. Construct a turnout/roadside landing as marked. Construct 1 turnout as marked. Construct a landing (approx. 50' diameter) as marked.			

***NOTES**

- Extra subgrade widths
Add to each shoulder: 1 ft. for fills of 1-6 ft. and 2 ft. for fills over 6 ft. Widen the inside shoulder of curves as follows:
(See Road Plan Map, Exhibit C)
- Backslopes
Materials Cut slopes Fill slopes
Solid rock 1:4:1 Angle of repose
Soft rock and shale 1:2:1
Common
Slopes under 55% 1:1 1-1/2:1
Slopes over 55% 3/4:1 1-1/2:1
Note:
Full bench construction is required on side slopes exceeding 60%.
- Surface type:
PRR - PR run rock Grading
GRR - Grid rolled rock A - 3"
SRN - Screened rock B - 2"
JRR - Jaw run rock C - 3" jaw run
ABC - Aggr. base course D - 6" jaw run
ASC - Aggr. surface course E - 1 1/2"-1"
WC - Wood chips D - 1"
E - 3/4"
- Turnouts
Width = 10 ft. in addition to subgrade width, or as shown on the plans.
Located approximately as shown on the plans.
Intervisible and not more than 7.5ft. apart.
- Surfacing
Turnouts, curve widening and road approach aprons shall be surfaced.
- Cleaning width
See Section 200.
- As posted and painted for Right-of-Way:
- Drainage
See Culvert List
- Compaction
See Sections 300 and 400.

*Clearing Limits as posted on ground

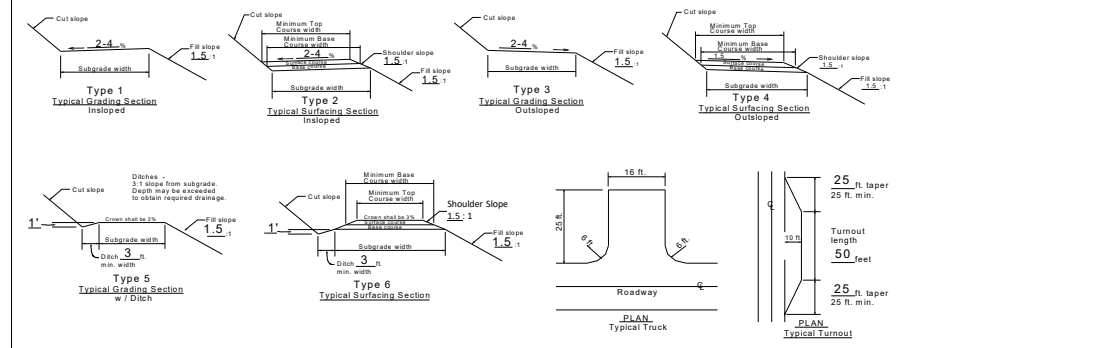

Road Number	Start Station or Milepost	End Station or Milepost	Total Length	Typical Cross Section	Min. Curve Radius	ROAD WIDTH		GRADIANT		SURFACING (*5)											Remarks
						Subgrade	Ditch	Max. Favorable	Max. Adverse	BASE COURSE					SURFACE COURSE						
										Min. Width	Comp. Depth	Surface Type (#3)	Grading Size (#3)	Number of Lifts	Min. Width	Comp. Depth	Surface Type (#3)	Grading Size (#3)	Number of Lifts		
5-7-22.0	0.000	3.466	3.466	6		14'	2'	--	--	--	--	ABC	D	--	--	--	ASC	C	--	Renovation. Re-establish ditchline and haul material to WA as directed. Spread 630 CY 6" Jaw Run Base Spot Rock as marked and needed. Spread 320 CY 1-1/2"-0" Crushed Spot Rock as marked. Place 395 CY 1-1/2"-0" Crushed Rock as marked. Construct 1 Waste Area/Stockpile site as marked. Construct 4 turnouts as marked. Construct 7 turnarounds as marked. Construct a landing (approx. 50' diameter) as marked. Widen subgrade to the left @ MP 0.264 as marked and directed. Re-establish ditchline in OHV disturbed area @ MP 3.263 as directed. Pile ditchline waste in designated waste areas as directed. Overflow tank discharging water into ditchline @ MP 0.133 is not to be disturbed. Install 7 Sediment Catch Basins with Straw Bales as marked. Replace 24 culverts (2 small fills & 4 medium fills). Install 2 culverts as marked. Install 28 inlet markers.	

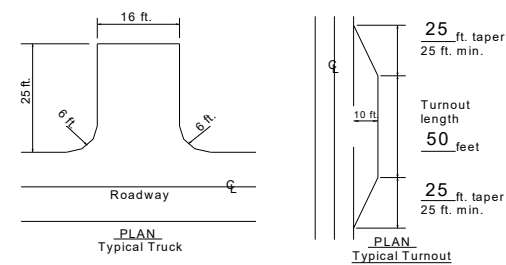
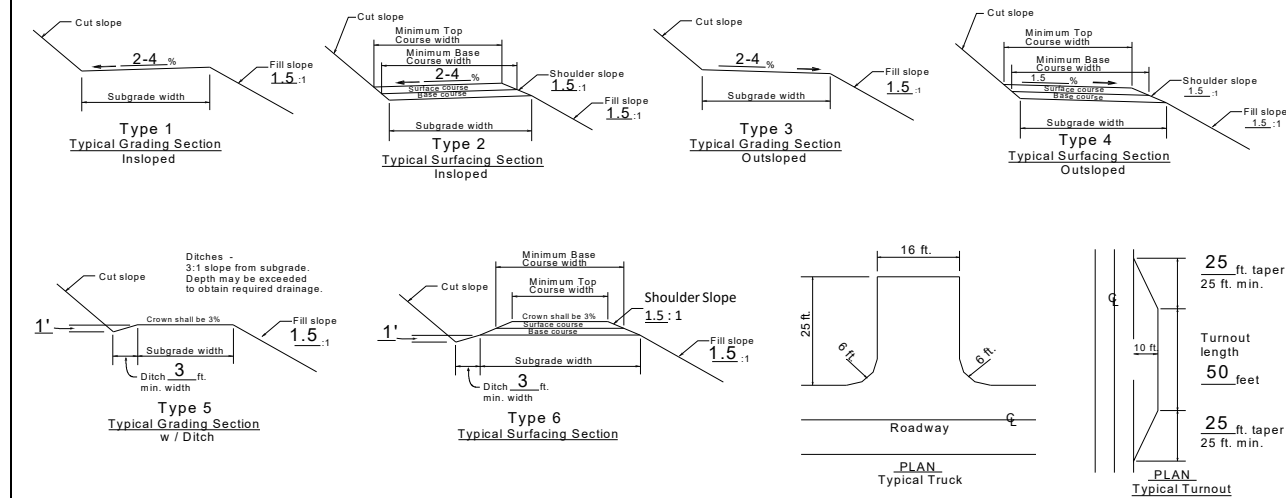

***NOTES**

- Extra subgrade widths**
 Add to each shoulder: 1 ft. for fills of 1-6 ft. and 2 ft. for fills over 6 ft. Widen the inside shoulder of curves as follows:
 (See Road Plan Map, Exhibit C)
- Backslopes**

Materials	Cut slopes	Fill slopes
Solid rock	1:4:1	Angle of repose
Soft rock and shale	1:2:1	
Common		
Slopes under 55%	1:1	1-1/2:1
Slopes over 55%	3/4:1	1-1/2:1

Note: Full bench construction is required on side slopes exceeding 60%.
- Surface type**

	Grading
PRR - Pit run rock	A - 3" (base course)
GRR - Grid rolled rock	B - 2" (base course)
SRN - Screened rock	C - 3" jaw run (base course)
JRR - Jaw run rock	D - 6" jaw run (base course)
ABC - Aggr. base course	C - 1 1/2" - 0"
ASC - Aggr. surface course	D - 1" (surface course)
WC - Wood chips	E - 3/4" (surface course)
- Turnouts**
 Width - 10 ft. in addition to subgrade width, or as shown on the plans. Located approximately as shown on the plans. Intervisible and not more than 750 ft. apart.
- Surfacing**
 Turnouts, curve widening and road approach aprons shall be surfaced.
- Clearing width**
 See Section 200.
- As posted and painted for Right-of-Way:**
- Drainage**
 See Culvert List
- Compaction**
 See Sections 300 and 400

*Clearing Limits as posted on ground

CLEARING AND GRUBBING - 200

- 201 - This work shall consist of clearing, grubbing, removing and disposing of vegetation, debris, surface objects, and protruding obstructions within the clearing limits in accordance with these specifications and conforming to the lines, grades, dimensions and typical cross sections shown on the plans and as marked on the ground.
- 201a - This work shall consist of clearing, grubbing, removing and disposing of vegetation, debris, surface objects, and protruding obstructions from borrow pits, quarries, channel changes, stockpile sites, etc., in accordance with these specifications and as staked on the ground.
- 202 - Where clearing limits have not been staked, established by these specifications or shown on the plans, the limits shall extend ten (10) feet back of the top of the cut slope and five (5) feet out from the toe of the fill slope.
- 202b - Where clearing limits for channel changes and waste areas have not been staked or shown on the plans, the limits shall extend ten (10) feet back of the top of the cut slope and five (5) feet outside of the outside slope lines.
- 203 - Clearing shall consist of the removal and disposal of trees, logs, rotten material, brush, and other vegetative materials and surface objects in accordance with these specifications and within the limits established for clearing as specified under Subsections 202 and 202b, as shown on the plans, and as marked on the ground.
- 203b - Standing trees and snags to be cleared shall be felled within the limits established for clearing, unless otherwise authorized. Felled snags shall be left as down woody debris outside of the clearing limits.
- 203c - Disposal of logs from private timber cleared within the limits established shall consist of decking at a location designated by the Authorized Officer.
- 204 - Grubbing shall consist of the removal and disposal of stumps, roots, and other wood material embedded in the ground and protruding obstacles remaining as a result of the clearing operation. Undisturbed stumps, roots and other solid objects which will be a minimum of four (4) feet below subgrades or slope surfaces or embankments are excluded.
- 204a - Stumps, including those overhanging cut banks, shall be removed within the required excavation limits.
- 205 - Clearing and grubbing debris shall not be placed or permitted to remain in or under road embankment sections.

- 206a - Notwithstanding Subsections 204 and 205, clearing and grubbing debris resulting from landing construction, waste area construction, turnaround construction, or log fill replacement shall be placed at disposal sites and shall not be covered with excavated material. Location of disposal sites will be determined by the Authorized Officer.
- 210 - Disposal of clearing and grubbing debris, stumps and cull logs shall be by scattering over government owned lands outside of established clearing limits in a manner acceptable to the Authorized Officer. The areas for such scattering shall have the prior approval of the Authorized Officer.
- 210a - Disposal of clearing and grubbing debris, stumps, and cull logs on non-government property shall be by scattering over non-government owned lands outside of established clearing limits in a manner acceptable to the Authorized Officer.
- 212 - No grading will be permitted prior to completion and approval by the Authorized Officer of the required clearing and grubbing work, except that stump grubbing may proceed with the excavation of the road prism.
- 213 - No clearing or grubbing debris shall be left lodged against standing trees.

EXCAVATION AND EMBANKMENT - 300

- 301 - This work shall consist of excavating, overhaul, placement of embankments, backfilling, borrowing, leveling, ditching, grading, outsloping, crowning and scarification of the subgrade, compaction, disposal of excess and unsuitable and slide materials, and other earth-moving work in accordance with these specifications and conforming to the lines, grades, dimensions, and typical cross sections shown on the plans.
- 302 - Excavation shall also consist of the excavation of road and landing cut sections, borrow sites, backfilling, leveling, ditching, grading, compaction, and other earth moving work necessary for the construction of the roadway in accordance with these specifications and conforming to the lines, grades, dimensions, and typical cross sections shown on the plans and as marked on the ground.
- 303 - Suitable material removed from the excavation shall be used in the formation of embankment subgrade, shoulders, slopes, bedding, backfill for structures, and for other purposes as shown on the plans.

- 304 - Borrow shall consist of suitable material required for the construction of embankments or for other portions of the work; such material shall be obtained from sources selected by the Purchaser at his option and approved by the Authorized Officer.
- 305 - Embankment construction shall consist of the placement of excavated and borrowed materials, backfilling, leveling, grading, compaction, and other earth-moving work necessary for the construction of the roadway and landings in accordance with these specifications and conforming to the lines, grades, dimensions, and typical cross sections shown on the plans and as marked on the ground.
- 305a - Material used in the construction of embankment sections shall be free of stumps, cull logs, brush, muck, sod, roots, frozen material, and other deleterious materials and shall be placed and compacted as specified.
- 305b - Embankment materials shall be placed in successive parallel layers on areas cleared of stumps, cull logs, brush, sod, and other vegetative and deleterious materials, except as provided under Subsection 204. Roadway embankments of earth material shall be placed in horizontal layers not exceeding eight (8) inches in depth.
- 305d - Where embankments are constructed predominantly of blasted rock material, depth of layers shall not exceed (4) feet. Rock fragments having dimensions greater than 4 feet will be permitted provided that they have no dimensions greater than (6) feet and that clearance between adjacent fragments is adequate for the placing and compacting of material in horizontal layers as specified, and that no part of the larger fragments comes within (4) feet of subgrade.
- 306 - Layers of embankment and selected borrow, as specified under Subsections 305a, 305b, and 317 shall be moistened or dried to a uniform optimum moisture content suitable for maximum density and compacted to full width with compacting equipment conforming to requirements of Subsections 103b, 103g, or 103i. Final Subgrades shall be moistened or dried to a uniform optimum moisture content suitable for maximum density and compacted to full width with compacting equipment conforming to requirements of Subsections 103f or 103i and approved by the Authorized Officer.
- 306a - Minimum compaction for each layer of embankment, selected borrow, and selected roadway excavation material placed at optimum moisture shall have a minimum compaction of six (6) passes over each full-width layer, or fraction thereof.

- 308 - In the case of rock fills, placement of material in layers is not required and such material may be placed by end-dumping or other methods approved by the Authorized Officer provided that the rock be reasonably prevented from escaping beyond the embankment toe.
- 311 - In solid rock cuts where pockets that will not drain are formed by blasting below the subgrade elevation, drainage shall be provided by ditching to the edge of the subgrade and backfilling to grade and compacting the pockets and the ditch with rock fragments, gravel, or other suitable porous material.
- 313 - In cut areas where solid rock is encountered at, or near subgrade, the rock shall be excavated to a minimum depth of six (6) inches below subgrade elevation and the excavated area backfilled with suitable material. The backfill material shall be processed to the optimum moisture content suitable for maximum density and compacted to full width in accordance with the requirements of Subsection 306.
- 314 - When heavy clays, muck, clay shale, or other deleterious material for forming the roadbed is encountered in cuts at subgrade, it shall be excavated to a minimum depth of two (2) feet below the subgrade elevation and the excavated area backfilled with a selected borrow material approved by the Authorized Officer. The backfill material shall be uniformly moistened or dried to the optimum moisture content suitable for maximum density in accordance with the requirements of Subsection 306. Unsuitable material shall be disposed of as directed by the Authorized Officer.
- 315 - Borrow material required for the construction of embankment or for other portions of the work shall be obtained from sources adjacent to the roadway.
- 316 - Borrow material from sources selected at the Purchaser's option shall be inspected and approved in writing by the Authorized Officer prior to placement.
- 317 - Selected borrow shall consist of talus material, finely broken rock, gravel, or other material of granular or favorable characteristics from sources shown on the plans.
- 320 - Ditches shall conform to the slope, grade, dimensions, and shape of the required cross section shown on the plans. Roots, stumps, rocks, and other projections shall be removed to form smooth, even slopes.
- 321 - Excess excavated, unsuitable, or slide materials shall not be disposed of on areas where the material will encroach on a stream course or other body of water. Such materials shall be disposed of in accordance with Subsection 321c. Materials not disposed of in this manner shall be retrieved and disposed of at the Purchaser's expense and at the direction of the Authorized Officer.

- 321c - End-dumping will be permitted for the placement of excess materials under Subsection 321 in designated disposal areas or within areas approved by the Authorized Officer. Watering, rolling, and placement in layers are not required. Materials placed shall be sloped, shaped, and otherwise brought to a visible condition acceptable to the Authorized Officer.
- 322 - When so indicated on the plans, selected coarse rock encountered in the excavation shall be conserved for slope protection or special rock embankment purposes and placed in accordance with the requirements and details of Section 1400 of these specifications and as shown on the plans.
- 323 - In the construction of channel changes and stream-crossing embankment sections, natural stream flow shall be maintained unless otherwise provided.
- 324 - Excavated material shall not be allowed to cover boles of standing trees to a depth in excess of a half (1/2) feet on the uphill side.
- 327 - The finished grading shall be approved by the Authorized Officer in segments or for the total project. The Purchaser shall give the Authorized Officer three (3) days' notice prior to final inspection of the grading operations.
- 328 - The Purchaser shall adopt methods and procedures in using explosives, which will prevent damage to adjacent landscape features, and which will minimize scattering rocks and other debris outside the road prism.
- 328a - The Purchaser shall establish and be responsible for blasting techniques and shall furnish the Authorized Officer, prior to starting drilling operations, a blasting plan specifying drill-hole diameter, drill-hole spacing, depth of drilling, type of explosive to be used, loading pattern, sequence of firing, the location where the plan is to be used, and other relevant data. Acceptance of the drilling and blasting plan does not relieve the Purchaser of responsibility or liability for the results of the blasting.

PIPE CULVERTS - 400

- 401 - This work shall consist of furnishing and installing pipe culverts, downspouts, and other erosion control devices in accordance with these specifications and conforming to the lines, grades, dimensions, and typical cross sections shown on the plans. Individual lengths and locations are approximate; final lengths and locations will be determined by the Authorized Officer upon completion of the roadbed and upon installation of the appurtenance structures. Additional pipe and erosion control devices may be required at the option of the Authorized Officer, in which case a reduction in the total purchase price shall be made to offset the cost

of furnishing and installing such items. Costs will be based upon the unit prices set forth in the current BLM Timber Appraisal Production Cost Schedule.

- 403 - Grade culverts shall have a gradient from two (2) percent to four (4) percent greater than the adjacent road grade. Grade culverts shall be skewed down grade thirty (30) degrees as measured from the perpendicular to the centerline unless otherwise specified on the plans.
- 404 - Damage to the spelter, or burn back in excess of three-eighths (3/8) inch, shall be wire brushed and painted with two coats of zinc-rich paint on zinc-coated steel pipe.
- 405a - Corrugated-(aluminized) steel-welded pipe culverts and pipe-arch culverts and special sections shall conform to the requirements of AASHTO M 36 and AASHTO M 218, AASHTO M 274, or AASHTO M 289 as specified on the plans.
- 405e - Corrugated-polyethylene pipe for culverts 18-inch through 24-inch diameter shall meet the requirements of AASHTO M 294, Type S.

Corrugated-polyethylene pipe for culverts to be used for downspouts 18-inch through 24-inch diameter shall meet the requirements of AASHTO M 294, Type C.

Installation will be subject to the same specification as other pipe materials.
- 406 - Coupling bands shall conform to the requirements of AASHTO M 36 and AASHTO M 274 with the exception of band widths and the "Hugger"-type band which shall conform to the details, dimensions, and typical diagram shown on the plans.
- 406a - "Hugger"-type coupling bands shall only be used with annular corrugated pipe and pipe-arch culverts, or helically corrugated pipe and pipe-arch culverts having annular reformed ends. Annular reformed ends shall consist of two annular corrugations.
- 406e - Neoprene gaskets shall be used to join aluminum pipe culverts.
- 408 - Pipe culverts shall be placed on the bed starting at the downstream end with the inside circumferential laps pointing downstream and with the longitudinal laps at the side or quarter points. Coupling bands of the type required under these specifications shall be installed so as to provide the circumferential and longitudinal strength necessary to preserve the pipe alignment, prevent separation of the pipe sections, and minimize infiltration of fill material.
- 409 - Structural-plate pipe culverts and pipe-arch culverts shall be installed in

accordance with the plans and detailed erection instructions furnished by the manufacturer. One copy of the erection instructions shall be submitted to the Authorized Officer (3) days prior to erection.

- 410 - Pipe shall be unloaded and handled with reasonable care. If the Authorized Officer determines any structure is damaged to the extent that it is unsuitable for use in the road construction, it shall be replaced at the Purchaser's expense.
- 411 - Trenches necessary for the installation of pipe culverts shall conform to the lines, grades, dimensions, and typical diagram included in the plans and the Culvert Installation Detail Sheet.
- 412 - Where ledge rock, boulders, soft, or spongy soils are encountered, they shall be excavated a minimum of twenty-four (24) inches below the invert grade for a width of at least one (1) pipe diameter or span on each side of the pipe and shall be backfilled with selected granular or fine readily compactable soil material or crushed rock material.
- 413 - All pipe culverts shall be bedded on a 1-1/2"-0" crushed rock material in accordance with Section 1200 gradation. Bedding shall have a depth of not less than six (6) inches as shown on plans. Foundation material shall be of uniform density throughout the length of the structure and shall be shaped to fit the pipe.
- 414a - The invert grade of the bedding shall be cambered at the middle ordinate a minimum of 1 percent of the total length of the drainage structure. Camber shall be developed on a parabolic curve.
- 415 - Inspection of pipe culverts having a diameter of (30) inches and pipe-arch culverts having a height of (40) inches or a cross sectional area of (13) or larger shall be made before backfill is placed. Culverts found to be out of alignment or damaged shall be replaced, reinstalled or repaired as directed by the Authorized Officer at the Purchaser's expense.
- 416 - Side-fill material for pipe culverts shall be placed within one (1) pipe diameter, or a minimum of one (1) foot, of the sides of the pipe barrel, and to a half (1/2) pipe diameter on round pipes with granular material (or 1-1/2"-0" crushed rock material in accordance with Section 1200 gradation if crushed bedding/backfill is required in the rock sheets and Section 413).

The remaining fill material shall be of fine, readily compactable soil and be free of excess moisture, muck, frozen material, roots, sod, or other deleterious or caustic material and devoid of rocks or stones of sizes which may impinge upon and damage the pipe or otherwise interfere with proper compaction.

- 419 - The pipe culverts, after being bedded and backfilled as required by these specifications, shall be protected by an 18” cover of fill before heavy equipment is permitted to cross the drainage structures.
- 421 - Trenches and bedding rock necessary for the installation of perforated pipe shall conform to the lines, grades, dimensions and typical diagram as shown on the plans.
- 423 - Construction of catch basins conforming to lines, grades, dimensions and typical diagrams shown on the plans, shall be required for grade culverts.
- 424 - Construction of splash pads and energy dissipaters conforming to lines, grades, dimensions and typical diagram shown on the plans, shall be required for grade culverts and culverts as listed on the culvert sheet.
- 426 - Culvert markers consisting of six (6) foot steel fence posts painted blue shall be furnished, fabricated, and installed by the Purchaser at the inlet of all culverts (installed and existing) as marked. Marker shall be installed within six (6) inches of upslope side of culvert inlet.
- 427 - The Purchaser shall record culvert sizes, lengths and location actually installed on a copy of the culvert list. This culvert list shall be furnished to the Authorized Officer.
- 428 - The Purchaser shall remove and dispose of old culverts (removed in the construction phase) in a legal manner, off of Government property, and pay any fees required. The Purchaser shall remove the old culverts from the work site prior to road acceptance.
- 429 - Keep the excavation site dewatered so that the installation of culverts is completed under dry conditions. Dispose of excess water by using pumping or natural drainage ways near the site in a manner that will avoid damage to adjacent property. Provide for downstream waterflow with no more than ten (10) percent increase in natural stream turbidity due to transport of excavated material or sediment during construction. Diversion streams shall not be returned to the natural channel until all in-stream work has been completed.
- 430 - During culvert installations or replacement activities, all stream flow shall be diverted around the culvert work occurring in live streams, as to maintain downstream flows and minimize turbidity. Woody material removed from stream channels during culvert work shall be placed in the stream channel downstream of the culvert.

RENOVATION AND IMPROVEMENT OF EXISTING ROADS - 500

- 501 - This work shall consist of reconditioning and preparing the roadbed and shoulders, minor excavation and/or embankment, cleaning and shaping drainage ditches, trimming vegetation from cut and embankment slopes, and cleaning and repairing drainage structures of existing roads in accordance with these specifications, as shown on the plans, and as marked on the ground.
- 501a - This work shall include the removal and disposal of slides in accordance with these specifications and as marked on the ground.
- 502 - The existing road surface shall be bladed and shaped to the lines, grades, dimensions, and typical cross sections shown on the plans.
- 502b - Drainage ditches shall be bladed and shaped in accordance with the lines, grades, dimensions, and typical cross sections shown on the plans.
- 503a - Material from the ditchline reestablishment excavation shall be hauled to designated disposal sites or at locations directed by the Authorized Officer.
- 504 - Existing road surface shall be uniformly moistened or dried to the optimum moisture content suitable for maximum density and compacted to full width with equipment conforming to requirements of Subsections 103f and 103i.
- 504a - Minimum compaction required shall be six (6) passes over each full-width layer, or fraction thereof, as measured along the centerline per layer of material.
- 506 - The inlet end of all existing drainage structures shall be cleared of vegetative debris and boulders that are of sufficient size to obstruct normal flow. Pipe inverts shall be cleared of sediment and other debris lodged in the barrel of the pipe. The outflow area of pipe structures shall be cleared of rock and vegetative obstructions which will impede the structure's designed outflow configuration. Catch basins shall conform to the lines, grade, dimensions, and typical diagram shown on the plans.
- 508 - Vegetation encroaching on the roadbed and the drainage ditches of existing roads shall be removed by cutting and disposed of in accordance with Subsection 2100 of these specifications.
- 509 - The finished grading and compacting shall be approved by the Authorized Officer. The Purchaser shall give the Authorized Officer three (3) days' notice prior to final inspection of the grading operations.

WATERING - 600

- 601 - This work shall consist of furnishing and applying water required for the compaction of embankments, roadbeds, backfills, base courses, surface courses, finishing and reconditioning of existing roadbeds, laying dust, or for other uses in accordance with these specifications.
- 602 - Water, when needed for compaction or laying dust, shall be applied at the locations, in the amounts, and during the hours as directed by the Authorized Officer. Amounts of water to be provided will be the minimum needed to properly execute the compaction requirements in conformance with these specifications.
- 603 - Water trucks used in this work shall be equipped with a distributing device of ample capacity and of such design as to ensure uniform application of water on the roadbed.
- 604 - Water required under these specifications shall be obtained at the times and at the locations indicated below:

Willamette Meridian			Dates Available		
Common Name	Section	T	R	From	To
1400 RD Pump Chance	21	4S	7W	TBD	TBD

Use of water sources are subject to applicable State water regulations. If the required water is not available at the locations specified, water shall be obtained from a source approved by the Authorized Officer as permitted by Oregon Water Resources. A reduction shall be made in the total purchase price to reflect additional hauling distance based on rental rates from current BLM Timber Appraisal Cost Schedules. It is estimated that approximately four hundred thousand (400,000) gallons will be required for processing rock.

- 605 - The Purchaser shall secure the necessary water permits and pay all required water fees for use of the water sources specified under Subsection 604 for use of water sources approved by the Authorized Officer. Purchaser shall notify the Bureau of Land Management when an agreement has been met and shall provide a copy of the documentation.

AGGREGATE BASE COURSE - 700
PIT-RUN ROCK MATERIAL

- 701 - This work shall consist of furnishing, hauling, and placing one or more layers of pit-run rock material on roadbeds and as backfill material approved for placing

pit-run materials in accordance with these specifications and conforming to the dimensions and typical cross sections shown on the plans.

- 702 - Pit-run rock materials used in this work shall be obtained from the source shown on the plans or sources approved by the Authorized Officer. Development and mining of such source shall be in accordance with section 1600 of these specifications.
- 702b - All rock required for project work in T. 05S., R. 07W., Sections 11 & 15 shall be obtained from a commercial source.
- 703 - Pit-run rock materials shall consist of talus rock, partly decomposed granite or basalt, or other approved materials. The materials shall be reasonably free from vegetative matter or other deleterious material. The material obtained from the sources identified under Section 1600 shall consist of the best material available from these sources as designated by the Authorized Officer.
- 704 - Pit-run rock material shall consist of native materials of such a size and grading that it can be taken directly from the source and placed on the road without crushing or screening.
- 705 - Pit-run rock material shall be placed in layers of sufficient thickness to accommodate the material as directed by Authorized Officer.
- 706 - Oversize material that cannot be accommodated in the layer shall be removed at the source or on the road and shall be disposed of as directed by the Authorized Officer.
- 707 - When so indicated by the plans, filler or binder obtained from the chosen sources shall be uniformly blended with pit-run rock material on the road.
- 708 - The Ditchline as shaped under sections 150, 300, and 500 of these specifications shall be approved by the Authorized Officer prior to placement of pit-run rock material. Notification for final inspection of base rock shall be three (3) days prior to the spreading of crushed cap rock.
- 709 - Pit-run rock material shall be placed on Ditchline blade processed and spread to required dimensions.

AGGREGATE BASE COURSE - 1000
CRUSHED ROCK MATERIAL

- 1001 - This work shall consist of furnishing, hauling, and placing one or more layers of crushed rock material on roadbeds and culvert bedding approved for placing crushed rock material, in accordance with these specifications and conforming to the dimensions and typical cross sections shown on the plans.

 Material not conforming to these specifications will be rejected and shall be removed from the road or stockpile at the purchaser’s expense.
- 1002 - Crushed rock materials used in this work shall consist of quarry rock, stone, gravel, or other approved materials obtained from the source shown on the plans. Development and mining of such source shall be in accordance with section 1600 of these specifications.
- 1002b - All rock required for project work in T. 05S., R. 07W., Sections 11 & 15 shall be obtained from a commercial source.
- 1003 - Crushed rock material produced from gravel shall have two (2) manufactured fractured faces on sixty-five (65) percent, by weight, of the material retained on the No. 4 sieve. If necessary to meet the above requirements or to eliminate an excess of filler, the gravel shall be screened before crushing.
- 1004 - Crushed rock material shall consist of hard durable rock fragments conforming to the following gradation requirements:

TABLE 1004
AGGREGATE BASE COURSE
CRUSHED ROCK MATERIAL
 Percentage by weight passing square mesh sieves
 AASHTO T 11 & T 27

GRADATION

Sieve Designation	D	A
6-inch	95	-
3-inch	45-65	95-100
1-1/2-inch	-	70-90
1-inch	-	-
¾-inch	-	50-70
No. 4	10 Max	-
No. 10	-	0-30
No. 40	-	0-10

- 1004a - The Purchaser shall be required to take one sample of each 2,000 cubic yards of crushed rock material produced, using approved AASHTO sampling procedures.

The Purchaser shall submit samples to a certified lab or shall perform testing for gradation requirements using AASHTO T 11 and AASHTO T 27 testing procedures and perform testing for sand equivalency requirements using AASHTO T 176 testing procedures. Prior to testing, each sample shall be split as requested by the Authorized Officer, making one-half of the sample with proper identification available for testing by the Authorized Officer. Each sample and the results of Purchaser testing shall be made available to the Authorized Officer within twenty-four (24) hours of receiving sampling results. The Purchaser shall provide test results for the first five hundred (500) cubic yards produced prior to commencing production crushing and hauling.

- 1005 - Crushed rock material shall not exceed thirty-five (35) percent loss as determined by AASHTO T 96.
- 1006 - Crushed rock material shall show a durability value of not less than thirty-five (35) as determined by AASHTO T210.
- 1007 - That portion of crushed rock material passing the No. 40 sieve, including blending filler, shall have a liquid limit of not more than thirty (35) and a plasticity index of not less than four (4) and not more than twelve (12) as determined by AASHTO T 89 and AASHTO T 90.
- 1008 - If additional binder or filler material is necessary to meet the grading or plasticity requirements or for satisfactory bonding of the material, it shall be uniformly blended with the crushed rock material at the crushing and screening plant prior to placing on the road, unless otherwise agreed. The material for such purposes shall be obtained from sources approved by the Authorized Officer and shall be free from stones, vegetative matter, and other deleterious materials.
- 1009 - Shaping and compacting of roadbed shall be completed and approved prior to placing crushed rock material, in accordance to the requirements of Subsections 300, 400, and 500. Notification for final inspection of base rock shall be three (3) days prior to the spreading of crushed cap rock.
- 1010 - Crushed rock material conforming to the requirements of these specifications shall be placed on the approved roadbed, turnarounds, and landings in accordance with these specifications and conforming to the lines, grades, dimensions, and typical cross sections shown on the plans and marked on the ground. Compacted layers shall not exceed nine (9) inches in depth. Irregularities or depressions that develop during compaction of the top layer shall be corrected by loosening the material at these places and then adding or removing crushed rock material until the surface is smooth and uniform.

- 1010a - Crushed rock material used to repair or reinforce soft, muddy, frozen, yielding, or rutted roadbed shall not be construed as surfacing required by this specification unless approved by the Authorized Officer in advance.

- 1012 - Each layer of crushed rock material placed, processed, and shaped as specified shall be moistened or dried to a uniform moisture content suitable for maximum compaction, determined by Authorized Officer, and compacted to full width by compacting equipment conforming to the requirements of Subsections 103f and 103i . Minimum compaction shall be six (6) passes over each full-width layer, or fraction thereof.

- 1016 - The Purchaser shall place in stockpile 6,753 cubic yards truck measure of Gradation D crushed rock material at sites, A, shown on the plans. The Purchaser shall place in stockpile 3,192 cubic yards truck measure of Gradation E crushed rock material at sites, A, shown on the plans. The Purchaser shall place in stockpile 1,195 cubic yards truck measure of Gradation D crushed rock material at sites, B-C, shown on the plans. Such material shall be used as shown on the plans and as directed by the Authorized Officer. All crushed rock material so stockpiled shall be placed on the designated roads prior to termination of the timber sale contract.

- 1017 - Prior to stockpiling Subsection 1004 Gradation D and E crushed rock material, the stockpile site shall be prepared by clearing and disposing of all trees, stumps, brush, and other debris in accordance with Section 200. The floor of each stockpile site shall be graded to a level and uniform cross section. A minimum of 11,140 cubic yards, stockpile measure, shall be placed amongst the following stockpile sites:

Stockpile No.	Willamette Meridian			Approx. Cu. Yds.	Road No.
	Sec.	T.	R.		
A (Whip Up Flats Quarry)	23	4	7	--	4-7-23.4
B (Commercial)	15	5	7	--	5-7-22.0
C (Commercial)	15	5	7	--	5-7-15.0

- 1018 - The equipment and methods used for stockpiling crushed rock material and for removing material from the stockpiles shall be such that minimum degradation or segregation of the material will result and that minimal amounts of foreign material will be incorporated into the crushed base material. There will be no intermingling of stockpiled materials.

- 1020 - Crushed rock material required under Section 1000 of these specifications shall first be placed in stockpile after crushing. The Purchaser shall notify the Authorized Officer a minimum of (3) days in advance of the date he intends to commence the crushing and stock-piling operation so that progressive test samples can be taken as the crushed rock material is produced. Sample material shall remain in separate stockpiles (2000 CY maximum) until such time the Authorized Officer receives test results which indicate compliance with Subsections 1003, 1004, 1004a, 1005, 1006, 1007, and 1008. Crushed rock material so tested shall be approved in writing by the Authorized Officer within (6) days from receiving sampling results date. Approved material may then be removed from temporary stockpile for placement on the designated roads or combined in designated base stockpile. In no event shall the Purchaser place crushed rock materials on the road from sources other than the tested and approved stockpiles. Noncompliance with the requirements of this subsection shall constitute grounds for the rejection of crushed rock materials furnished under this contract.

AGGREGATE SURFACE COURSE – 1200
CRUSHED ROCK MATERIAL

- 1201 - This work shall consist of furnishing, hauling, and placing one (1) or more layers of crushed rock material on roadbeds, base courses, and culvert bedding approved for placing crushed rock material in accordance with these specifications and conforming to the dimensions and typical cross sections shown on the plans. Material not conforming to these specifications will be rejected, and shall be removed from the road or stockpile at the purchaser's expense.
- 1202 - Crushed rock materials used in this work shall consist of quarry rock, stone, gravel, or other approved materials obtained from source shown on the plans. Development and mining of such source shall be in accordance with section 1600 of these specifications.
- 1202b - All rock required for project work in T. 05S., R. 07W., Sections 11 & 15 shall be obtained from a commercial source.
- 1203 - When crushed rock material is produced from gravel, not less than seventy-five (75) percent by weight of the particles retained on the No. 4 sieve will have 4 manufactured fractured faces. If necessary to meet the above requirements or to eliminate an excess of filler, the gravel shall be screened before crushing.
- 1204 - Crushed rock material shall consist of hard durable rock fragments conforming to the following gradation requirements:

TABLE 1204
AGGREGATE SURFACE COURSE
CRUSHED ROCK MATERIAL
 Percentage by weight passing square mesh sieves
 AASHTO T 11 & T 27
 GRADATION

Sieve Designation	C	E
1-1/2-inch	95	-
1-inch	-	-
3/4-inch	60-90	100
1/2-inch	-	-
No. 4	30-55	40-75
No. 8	22-43	-
No. 30	11-27	-
No. 40	-	5-35
No. 200	3-15	2-15

- 1204a - The Purchaser shall be required to take one sample for each 1,000 cubic yards of crushed rock material to be utilized using AASHTO sampling procedures. The Purchaser shall submit samples to a certified lab or perform testing for gradation requirements using AASHTO T 11 and AASHTO T 27 testing procedures and also perform testing for sand equivalency requirements using AASHTO T 176 testing procedures. Prior to testing, each sample shall be split as requested by Authorized Officer, making one half of the sample, with proper identification, available for testing by the Authorized Officer. Each sample and the results of Purchaser testing shall be made available to the Authorized Officer within 24 hours of receiving sampling results. The Purchaser shall provide test results for the first (500) cubic yards produced prior to commencing production crushing and hauling.

- 1205 - Crushed rock material retained on the No. 4 sieve shall have a percentage of loss of not more than thirty-five (35) at five hundred (500) revolutions, as determined by AASHTO T 96.

- 1206 - Crushed rock material shall show a durability value of not less than thirty-five (35) as determined by AASHTO T210.

- 1207 - That portion of crushed rock material passing the No. 40 sieve, including blending filler, shall have a liquid limit of not more than thirty-five (35) and a plasticity index of not less than four (4) and not more than twelve (12) as determined by AASHTO T 89 and AASHTO T 90.

- 1208 - If additional binder or filler material is necessary to meet the grading or plasticity requirements or for satisfactory bonding of the material, it shall be uniformly blended with the crushed rock material at the crushing and screening plant prior to placing on the road, unless otherwise agreed. The material for such purposes shall be obtained from sources approved by the Authorized Officer and shall be free from stones, vegetative matter, and other deleterious materials.
- 1209 - Shaping and compacting of roadbed, base course, or culvert trench shall be completed and approved prior to placing crushed rock material, in accordance to the requirements of Subsections 300, 400, 500, and 700. Notification for final inspection of base rock shall be three (3) days prior to the spreading of crushed cap rock.
- 1210 - Crushed rock material conforming to the requirements of these specifications shall be placed on the approved roadbed, landings, base course and culvert trench in accordance with these specifications and conforming to the lines, grades, dimensions, and typical cross sections shown on the plans and marked on the ground. Compacted layers shall not exceed 4 inches in depth. When more than one (1) layer is required, each shall be shaped, processed, compacted, and approved by the Authorized Officer before the succeeding layer is placed.
- Irregularities or depressions that develop during compaction of the top layer shall be corrected by loosening the material at these places and then adding or removing crushed rock material until the surface is smooth and uniform.
- 1210a - Crushed rock material used to repair or reinforce soft, muddy, frozen, yielding, or rutted roadbed shall not be construed as surfacing required by this specification unless approved by the Authorized Officer in advance.
- 1212 - Each layer of crushed rock material placed, processed, and shaped as specified shall be moistened or dried to a uniform moisture content suitable for maximum compaction, as determined by Authorized Officer, and compacted to full width by compacting equipment conforming to the requirements of Subsections 103f, 103g, and 103i . Minimum compaction shall be six (6) passes over each full-width layer, or fraction thereof.
- 1216 - The Purchaser shall place in stockpile 10,731 cubic yards truck measure of Gradation C crushed rock material at site, A, shown on the plans. The Purchaser shall place in stockpile 2,160 cubic yards truck measure of Gradation C crushed rock material at site, B-C, shown on the plans. Such material shall be used to reinforce and repair areas of deficient support which appear during the hauling operation. Crushed rock material so stockpiled shall be placed on the designated road prior to termination of the timber sale contract.
- 1217 - Prior to stockpiling Subsection 1204 Gradation C crushed rock material, the

stockpile site shall be prepared by clearing and disposing of all trees, stumps, brush, and other debris in accordance with Section 200. A minimum of 12,891 cubic yards, stockpile measure, shall be placed at the following stockpile sites:

Stockpile No.	Willamette Meridian			Approx. Cu. Yds.	Road No.
	Sec.	T.	R.		
A (Whip Up Flats Quarry)	23	4	7	--	4-7-23.4
B (Commercial)	15	5	7	--	5-7-22.0
C (Commercial)	15	5	7	--	5-7-15.0

- 1218 - The equipment and methods used for stockpiling crushed rock material and for removing material from the stockpiles shall be such that minimum degradation or segregation of the material will result and that minimal amounts of foreign material will be incorporated into the crushed base material and that there will be no intermingling of stockpiled materials.

- 1220 - Crushed rock material required under Section 1200 of these specifications shall first be placed in stockpile after crushing. The Purchaser shall notify the Authorized Officer a minimum of (3) days in advance of the date he intends to commence the crushing and stockpiling operations so that progressive test samples can be taken as the crushed rock material is produced. Sampled materials shall remain in separate stockpiles (1,000 CY maximum) until such time the Authorized Officer receives test results which indicate compliance with Subsections 1203, 1204, 1204a, 1205, 1206, 1207, 1208, and 1208a. Crushed rock material so tested shall be approved in writing by the Authorized Officer within 6 days from receiving sampling results date. Approved material may then be removed from temporary stockpile for placement on the designated road or combined in designated crushed rock stockpile. In no event shall the Purchaser place crushed rock materials on the road from sources other than the tested and approved stockpiles. Noncompliance with the requirements of this subsection shall constitute grounds for the rejection of all crushed rock materials furnished under this contract.

SLOPE PROTECTION - 1400

- 1401 - This work shall consist of furnishing, hauling, and placing stone materials for slope protection structures, splash pads, and road blockages in accordance with these specifications and conforming to the lines, grades, dimensions, and typical cross-sections shown on the plans. Material not conforming to these

specifications will be rejected and shall be removed from the slope protection structure at the purchaser's expense and as directed by the Authorized Officer.

- 1402 - Stone material shall consist of hard angular quarry rock of such quality that it will not disintegrate on exposure to water or weathering, and shall be graded in accordance with these specifications.

Volume/ Cubic Foot	Average Dimension in inches	Approximate Weight in Pounds
12	27.5 x 27.5 x 27.5	2100
6	21.8 x 21.8 x 21.8	1050
4	19.1 x 19.1 x 19.1	700
3	17.3 x 17.3 x 17.3	525
1	12.0 x 12.0 x 12.0	175
2/3	10.5 x 12.0 x 12.0	120
1/2	9.5 x 9.5 x 9.5	88
1/3	8.3 x 8.3 x 8.3	60
1/4	7.6 x 7.6 x 7.6	44
1/6	6.6 x 6.6 x 6.6	30
1/8	6.0 x 6.0 x 6.0	22
1/100	2.6 x 2.6 x 2.6	2

- 1404 - The material shall be well graded from the smallest to the maximum size specified. Stones smaller than the specified ten (10) percent size shall consist of spalls and fine rock fragments so distributed as to provide a stable compact mass.

- 1405 - Rip rap shall conform to the following gradations:

TABLE 1405

Class	% of Rock Equal of Smaller by Count, Dx	Range of Intermediate Dimensions, inches	Range of Rock Mass, pounds
5	100	33-39	2900-4850
	85	23-28	990-1800
	50	17-20	400-650
	15	11-15	110-270

Rocks smaller than six inches in diameter are not counted.

- 1405a - Stone materials shall show a durability value of not less than fifty (50) as determined by AASHTO T 210.

- 1406a - The embankment shall be placed in successive horizontal layers of sufficient depth to contain the maximum size rock present in the material. Spalls and finer fragments of stone other than specified in Subsection 1405 shall be used to chock the larger stones solidly in position and to fill voids between the major stones as laid in the embankment. The exposed face of the embankment shall be reasonably smooth and uniform; material shall be prevented from escaping beyond the toe of the structure
- 1407 - Determination of the acceptability of the slope protection material gradation will be through visual inspection and physical measurements by the Authorized Officer.
- 1408 - Trenches for slope protection structures shall be excavated to the lines, elevations, and typical diagram shown on the plans. They shall be of sufficient size to permit the placing of structure footing of the full widths and length shown. Trenches shall be approved by the Authorized Officer prior to placement of slope protection material.
- 1408a - Foundation trenches and other required excavation as shown on the plans shall be approved prior to placing the slope protection material.

QUARRY AND BORROW PIT DEVELOPMENT - 1600

- 1601 - This work shall consist of quarry development and rehabilitation in accordance with these specifications and conforming to the lines, grades, dimensions, and typical cross sections shown on the plans.
- 1602 - The designated rock quarry site is located at the following location:

Willamette Meridian		
Section	T	R
23	4S	07W

A development, mining, and reclamation plan, (in accordance with appendix C1) shall be prepared by the Purchaser, and submitted for approval by the Authorized Officer prior to any Whip Up Flats Quarry activities. The Purchaser shall perform reclamation work in accordance with the requirements of Subsection 1617, as shown on the plans, and as directed by the Authorized Officer. Any surplus rock blasted, crushed, or stockpiled will belong to the BLM.

- 1603 - If the Purchaser elects to use a rock source other than the designated source, the rock material produced shall comply with applicable sections of these

specifications. If the alternate source is located on BLM ownership and a current BLM plan is not available, a development, mining, and reclamation plan shall be prepared by the Purchaser, and submitted for approval by the Authorized Officer. Development, mining, and reclamation work shall be in accordance with the approved plan and 1600 specifications.

- 1604 - If the designated source proves insufficient as to quantity and quality of the required rock material, the Purchaser shall, when ordered in writing by the Authorized Officer, move his operation to an alternate materials source or a change in gradation specifications directed by the Authorized Officer. An equitable adjustment will be made in the contract price.
- 1605c - The operation of equipment related to the production of rock aggregate and quarry operations shall be confined to the quarry operations area and to the designated tractor trails.
- 1607b - Slash, stumps, logs, and other organic debris shall be piled at the locations shown on the plans and as directed by the Authorized Officer.
- 1608 - Overburden or reject material which does not conform to the requirements of sections 700, 900, 1000, and 1200 shall be wasted as shown on the plans.
- 1609 - Overburden, trees, stumps, logs, and loose rock shall be removed back from the edge of working quarry faces for a minimum distance of ten (10) feet.
- 1610 - Waste disposal sites shall be selected and prepared to minimize erosion and establish conditions conducive to vegetative growth. Disposal areas shall be seeded and mulched in accordance with the requirements set forth in Section 1800 of these specifications.
- 1611 - The Purchaser shall notify the Authorized Officer in writing at least two (2) days prior to commencing quarry operations.
- 1611a - The Purchaser shall not commence production drilling or crushing until the Authorized Officer has inspected and approved the site development.
- 1612 - The Purchaser shall notify MSHA (Mining Safety and Health Administration) by standard form or telephone, and in accordance with part 56, Chapter 1 of Title 30 Code of Federal Regulations (CFR), of what date he intends to commence, terminate, and/or temporarily close down operations of the pit. Notice shall be submitted a minimum of ten (10) days prior to the proposed date of the action to be taken. Notification shall be submitted to:

Mining Safety and Health Administration
Albany, OR 97321
or
Mining Safety and Health Administration
Bellevue, WA 98004

The Purchaser shall also prepare and submit to MSHA the quarterly Employment Report and Injury and Illness Report for the mining operation.

- 1613 - The Purchaser shall comply with local and State Safety Codes covering quarrying operations, warning signs, seismic monitoring, and traffic control. All quarrying operations will be conducted by appropriately licensed personnel; i.e. blasting and powder handler's license, etc.
- 1613b - Controlled blasting techniques shall be employed during production blasting to contain blasted rock.
- 1614a - Existing and oversized rock on the quarry floor shall be utilized before drilling and shooting new rock. Oversized boulders shall not be wasted but shall be broken and utilized concurrent with acceptable material.
- 1615 - Operations on the quarry site shall be so conducted that, both during and after completion of work, erosion will be minimized and sediment will not enter streams or other bodies of water. Waste or disposal areas and quarry access roads shall be located, constructed, and maintained in a manner that will prevent sediment from entering live streams or other bodies of water. Noncombustible debris and silt-laden water material resulting from the quarry operations shall be placed in such waste or disposal areas as shown on the plans and as directed by the Authorized Officer.
- 1616 - Upon completion of quarrying operations, overburden and waste materials shall be disposed of in accordance with requirements of the approved pit plan or in a manner approved in writing by the Authorized Officer.
- 1617 - Upon completion of quarrying operations, required site reclamation measures shall be performed to the satisfaction of the Authorized Officer.

EROSION CONTROL - 1700

- 1701 - This work shall consist of measures to control soil erosion or water pollution during the construction operation through the use of berms, dikes, dams, sediment basins, fiber mats, netting, gravel, mulches, grasses, slope drains, and other

erosion control devices or methods in accordance with these specifications and conforming to the lines, grades, dimensions and typical cross sections shown on the plans.

- 1704 - The erosion control provisions specified under this Subsection shall be coordinated with the Soil Stabilization requirements of Section 1800 and the Geotextile requirement of Section 1300.
- 1708 - Newly constructed and renovated roads to be carried over the winter period, shall be blocked to vehicular traffic and waterbars installed prior to the wet season.
- 1708a - Road segments not completed during dry weather periods shall be winterized, by providing a well-drained roadway using waterbars, maintaining drainage, and performing additional measures necessary to minimize erosion and other damage to the roadway, as directed by the Authorized Officer. Portions of roads not having surface rock in place will be blocked or barricaded to prevent vehicular traffic. A winterization plan shall be submitted to the Authorized Officer no later than September 15th of each harvest season.
- 1711 - The Purchaser shall construct sediment catch basins with straw bales at the following locations: 4-6-7.4 (Sta. 6+33), 4-7-1.4 (MP. 0.352, 0.370), 4-7-11.2 (MP. 0.019, 0.065, 0.078, 0.298, 0.537, 0.550, 0.715, 0.730, 0.853, 0.898, 1.074, 1.088, 1.133), 4-7-13.9 (Sta. 2+56, 4+32), 4-7-15.1 (MP. 0.887, 0.905, 1.138, 1.770, 1.936, 2.028, 2.043, 2.087, 2.099, 2.355, 2.359, 2.849, 2.858, 2.951, 2.962), 4-7-24.0 (MP. 0.431, 0.457, 0.819, 0.836, 0.889), 4-7-24.0B (Sta. 11+58, 11+90), 4-7-24.1 (MP. 0.089), 4-7-27.2 (MP. 0.030, 0.084, 0.114, 0.238, 0.516), 4-7-36.0 (MP. 0.116, 0.123, 0.432, 0.441, 0.655, 0.995, 1.039, 1.137, 1.148, 1.388, 2.050, 2.072, 2.608, 2.625, 2.710, 2.803, 3.269, 3.423, 3.715, 4.058, 4.150, 4.162, 4.234, 4.627, 4.758, 4.870, 4.882, 5.409), and 5-7-22.0 (MP. 0.271, 1.145, 1.311, 1.480, 1.518, 1.794, 1.812). Construct sediment catch basins to the dimensions of the sediment catch basin detail on Pg. 53 of Exhibit C.
- 1711a - Straw bales required for sediment catch basins shall be furnished by the Purchaser. Straw bales shall be certified weed free from commercial grain fields and native grass fields. Straw bales shall be from oats, wheat, rye, or other approved grain crops and shall be free from, mold, or other objectionable material. Straw bales shall be in an air-dry condition and suitable for placement. The Purchaser shall provide the weed free certification to the Authorized Officer upon request.

SOIL STABILIZATION – 1800

- 1801 - This work shall consist of seeding on designated cut, fill, borrow, disposal, and special areas in accordance with these specifications and as shown on the plans. This work is not required for road acceptance under Section 18 of this contract. Grass seed will be furnished by the Government. Straw Mulch shall be furnished by the Government.
- 1802a - Soil stabilization work consisting of seeding and mulching shall be performed on new road construction, road renovation and improvement, landings, borrow sites, and disposal sites in accordance with these specifications and as shown on the plans. The seed shall be spread at a rate of sixty 60 pounds/acre.
- 1803 - Soil stabilization work as specified under Subsection 1802a shall be performed during the following seasonal periods:

From	To
August 1	October 15

The Authorized Officer may modify the above seasonal dates to conform to existing weather conditions and changes in the construction schedule.

- 1809 - Mulch material conforming to the requirements of Subsections 1809a and 1809b shall be furnished by the Government and shall be delivered to the work area in a dry state. Material to be used in the mulching operation may be stockpiled along the road designated for treatment provided that it is maintained in a dry state and has the approval of the Authorized Officer.
- 1809a - Straw mulch shall be from oats, wheat, rye, or other approved grain crops which are free from noxious weeds, mold, or other objectionable materials. Straw mulch shall be in an air-dry condition and suitable for placing with power spray equipment.
- 1809b - Grass straw mulch shall be from perennial grass or, if specified, an annual rye grass, from which the seed has been removed. The straw shall be free from Bentgrass, Canada Thistle, Tansy Ragwort, Skeleton weed, and other noxious weed seed. The grass straw shall be from fields which have passed the current year’s field inspection of the Oregon Grass Seed Certification program, or from fields certified by the County Agent, or by seed companies purchasing the seed.
- 1810 - Bulk mulching material required under these specifications shall be delivered to the work area bound either by twine, string or hemp rope. Wire binding will not be permitted.
- 1811 - The Purchaser shall apply to the disturbed soils that are wet and/or within fifty (50) feet each side of “live stream” locations and all disposal sites a mixture of

grass seed and straw mulch material at the application rate of six (6) pounds seed/acre and three thousand (3000) pounds straw mulch/acre (to be determined by Authorized Officer based on visual observation of trial applications).

- 1814 - The Purchaser may reduce the application rate on partially covered slopes and refrain from application on areas already well stocked with grass or on rock surfaces as determined by the Authorized Officer.
- 1815b - Dry Method - Blowers, mechanical seeders, seed drills, landscape seeders, cultipacker seeders, fertilizer spreaders, or other approved mechanical seeding equipment may be used when seed and fertilizer are to be applied in dry form.
- 1819 - The Purchaser shall notify the Authorized Officer at least three (3) days in advance of date he intends to commence the specified soil stabilization work.
- 1824 - Twine, rope, sacks, and other debris resulting from the soil-stabilization operation shall be picked up and disposed of to the satisfaction of the Authorized Officer.

ROADSIDE BRUSHING - 2100

- 2101 - This work shall consist of the removal of vegetation from the road prism - variable distance, and inside curves in accordance with these specifications and conforming to the lines, grades, dimensions, and typical cross sections shown on the Roadside Brushing Detail Sheet of this exhibit, at designated locations as shown in the plans.
- 2102 - Roadside brushing may be performed mechanically with self powered, self-propelled equipment, or manually with hand tools, including chain saws.
- 2103 - Vegetation cut manually or mechanically less than six (6) inches in diameter shall be cut to a maximum height of two (2) inches above the ground surface or above obstructions such as rocks or stumps on cut and fill slopes and all limbs below the six (6) inch area will be severed from the trunk.
- 2104 - Trees in excess of six (6) inches in diameter shall be limbed, so that no limbs extend into the treated area or over the roadbed to a height of fourteen (14) feet above the running surface of the roadway on cut and fill slopes, within the road prism-variable distance. Limbs shall be cut to within four (4) inches of the trunk to produce a smooth vertical face. Removal of trees larger than six (6) inches in diameter for sight distance or safety may be directed by the Authorized Officer.
- 2105 - Vegetation that is outside of the road prism-variable distance that protrudes into the road prism and within fourteen (14) feet in elevation above the running surface shall be cut, to within four (4) inches of the trunk to produce a smooth vertical face.

- 2106 - Vegetative growth capable of growing one (1) foot in height or higher shall be cut, within the road prism-variable distance or as directed by the Authorized Officer.

- 2107 - Inside curves shall be brushed out for a sight distance of two hundred (200) feet chord distance and/or a middle ordinate distance of twenty-five (25) feet, whichever is achieved first. Overhanging limbs and vegetation in excess of one (1) foot in height, shall be cut within these areas.

- 2109 - Debris resulting from this operation shall be scattered downslope from the roadway. Debris shall not be allowed to accumulate in concentrations. Debris in excess of one (1) foot in length and two (2) inches in diameter shall not be allowed to remain on cut slopes, ditches, roadways or water courses, or as directed by the Authorized Officer.

- 2112 - Roadside brushing shall be performed during the following seasonal periods:

*From	To
June 1	October 15

*Brushing may occur during the “wet season” given the following guidelines are followed:

- 1) Activity would be suspended when conditions exist that could generate sediment inputs into streams, such as times of intense or prolonged rainfall where water in ditches is flowing, or streamflow, as measured above and below the effects of the road, becomes discolored.

 - 2) Activity would be suspended when road surface shows signs of serious deterioration such as excessive rutting or pumping of fines from the sub-grade.

 - 3) Activity would be suspended upon decision of Authorized Officer.
-
- 2113 - Roadside brushing shall be accomplished on the following road segments: 4-7-1.4 (MP. 0.000 – 0.649), 4-7-11.2, 4-7-12.0A, 4-7-12.1, 4-7-13.0, 4-7-13.2, 4-7-13.5, 4-7-13.6, 4-7-13.7, 4-7-13.9, 4-7-13.10, 4-7-14.3, 4-7-14.11, 4-7-15.1, 4-7-24.0, 4-7-24.1, 4-7-24.2, 4-7-27.2, 4-7-36.0 (MP. 0.000 – 5.357), 5-7-3.0, 5-7-15.0 (MP. 0.000 – 1.091), and 5-7-22.0.

 - 2116 - Traffic warning signs shall be required at each end of the work area. Signs shall meet the requirements of the Manual on Uniform Traffic Devices.

SLOPE STAKING – 2300

- 2301 - This work shall consist of slope staking and referencing road locations from slope stake notes furnished by the BLM in accordance with these specifications and conforming to the lines, grades, dimensions, and typical cross sections shown on the plans.
- 2302 - Slope stakes shall consist of 1-3/4 inch x 1/4 inch smooth-finished wood slats of good quality, approximately eighteen 18 inches in length and tipped with red luminous paint.
- 2303 - Slope stakes shall be set as follows:
- (a) A slope stake shall be set at the top of the cut slope for cut and fill and full bench sections.
 - (b) For fill sections, only the uphill side shall be staked, unless otherwise specified.
 - (c) For balanced sections both sides of the road shall be staked.
 - (d) Stakes shall be set at a maximum interval of one hundred 100 feet and at a maximum interval of fifty 50 feet on curves.
 - (e) The slope stake shall be left in the slope stake location at time of staking. The Purchaser shall reset the slope stakes after completion of clearing and grubbing operations, where needed.
- 2304 - A reference marker consisting of a yellow plastic tag nailed or stapled to the base of a stump or tree shall be set for each slope stake. If no stumps or trees are available, a stake identical to that used for slope staking may be used. Reference markers shall be readily visible from the slope stake and shall be set outside of the posted right-of-way.
- 2309 - Stationing used is "L" or final location stationing.
- 2310 - Stakes shall be marked with black-lumber crayon or with a permanent waterproof felt-tip marker.
- 2311 - Slope and reference stakes shall be set to the following standards of accuracy:

maximum allowable horizontal error +/-	Two (2) feet
maximum allowable vertical error +/-	One (1) foot

- 2313 - The BLM will slope stake and reference and furnish the Purchaser the resulting notes in advance of construction on the roads shown below:

Road No.	Approximate Sta/Mi.
4-6-7.4	Sta. 5+53 – 25+77

- 2314 - Data for slope staking is available at the BLM Northwest Oregon District (Tillamook Field Office). P - Ground, Grade, Shift, and Template information shall be used to determine actual slope staked location.

HOT MIX ASPHALT CONCRETE PAVING - 2600

- 2601 - This work shall consist of furnishing, applying, and compacting Hot Mix Asphalt Concrete on prepared surfaces, in the depths, amounts, and locations as marked in field and directed by Authorized Officer.
- 2602 - Submit two copies of the bituminous job mix formula to be used on this project three weeks prior to placement of paving. The Purchaser shall have written approval of the formula by the Authorized Officer prior to placement of pavement.
- 2603 - Vehicular traffic, including heavy equipment, will not be permitted on the pavement until all rolling and compacting operations have been completed.
- 2604 - Place bituminous mixture only when air temperature is above 45 degrees F, on surfaces that do not have standing water, and when it is not raining.
- 2605 - Asphalt paving shall conform to the Oregon Department of Transportation, Level III, 1/2" dense, PG 64-22 Asphalt Binder mix for use on roadways. Furnish aggregate that conforms to the aggregate requirements for hot mix asphalt concrete by the Oregon Department of Transportation.
- 2606 - Aggregate shall be tested by AASHTO T11 and T27. The aggregate selected for use in the work shall have a gradation within the limits designated in Table 2606.

TABLE 2606

TOLERANCE GRADATION OF AGGREGATES

Total Percentage by Weight Passing Square Mesh Sieves
 (AASHTO T 11 and AASHTO T 27)

Sieve Size	Percent
------------	---------

¾ inch	100
½ inch	90-100
No. 4	JMF +/- 5
No. 8	JMF +/- 4
No. 30	JMF +/- 4
No. 200	JMF +/- 2

JMF = Job Mix Formula

- 2607 - Bituminous material shall meet the requirements of AASHTO M320.
- 2608 - Water shall be clean and free from deleterious materials.
- 2609 - The asphalt spreader shall be capable of spreading hot bituminous mixtures without tearing, shoving, or gouging and produce a finished surface of the specified grade and smoothness.
- 2610 - The number, type and weight of rollers shall be sufficient to compact the mixture to the required density without detrimentally affecting the compacted material. All rollers shall be suitable for rolling hot mix bituminous pavements and capable of being operated without turning on the mat and without loosening the surface being rolled. Rollers shall have suitable devices and apparatus to keep the rolling surfaces wet and prevent adherence of bituminous mixture.
- 2611 - Make pavement cuts with parallel, straight lines, 1 foot wider than trench width on each side of trenches.
- 2612 - Prior to laying the asphalt concrete pavement the Purchaser shall obtain written approval from the Authorized Officer by showing satisfactory test results of the crushed aggregate base course that has been tested and meets the requirements of the specifications.
- 2613 - Prior to laying the asphalt concrete, remove unsuitable material from the underlying course.
- 2615 - Restore disturbed edges of existing bituminous pavements, matching existing edges.
- 2616 - The thickness of the asphalt concrete pavement shall be as shown on the 150 sheets.
- 2617 - Plants used for the preparation of bituminous mixtures shall conform to AASHTO M156 and to Oregon Department of Transportation requirements.
- 2618 - Transport bituminous material from the mixing plant to the paving site in trucks having tight, clean, smooth beds that have been coated with a minimum amount of concentrated solution of hydrated lime and water or other approved coating to prevent adhesion of the mixture to the truck bodies. Petroleum products will not

be permitted for coating truck bodies. When the air temperature is less than 60 degrees F or if haul time is greater than 30 minutes, cover each load with canvas or other approved material of ample size to protect the mixture from the loss of heat.

- 2619 - Compact each layer of Hot Mix Asphalt Concrete to a minimum density of 91 percent of the maximum specific gravity determined by AASHTO T166 and T209. Percent compaction will be determined from at least one production sample per day.

BARRICADES AND CONTROL DEVICES - 2700

- 2701 - This work will consist of furnishing and placement of barricades, warning signs, and other protection required to prevent injury to people and damage to property due to culvert installations, brushing, and other construction work. Purchaser shall submit a site plan showing how the specifications in this section and of Sec. 44 will be accomplished.
- 2702 - Maintain condition, operation, and effectiveness of traffic control devices throughout period of use. Materials used for the temporary structures and controls are property of Contractor and shall be removed from Government land when need for their service has ended.

**United States Department of Interior
BUREAU OF LAND MANAGEMENT
NORTHWEST OREGON DISTRICT - OREGON
Road Plan Map**

T. 04S. R. 07W. Sections 1, 12, 13, 14, 15, 23, & 24 W.M. - NORTHWEST OREGON DISTRICT - OREGON
T. 04S. R. 06W Sections 6, 7, & 18 W.M. - NORTHWEST OREGON DISTRICT - OREGON
T. 05S. R. 07W. Sections 11 & 15 W.M. - NORTHWEST OREGON DISTRICT - OREGON

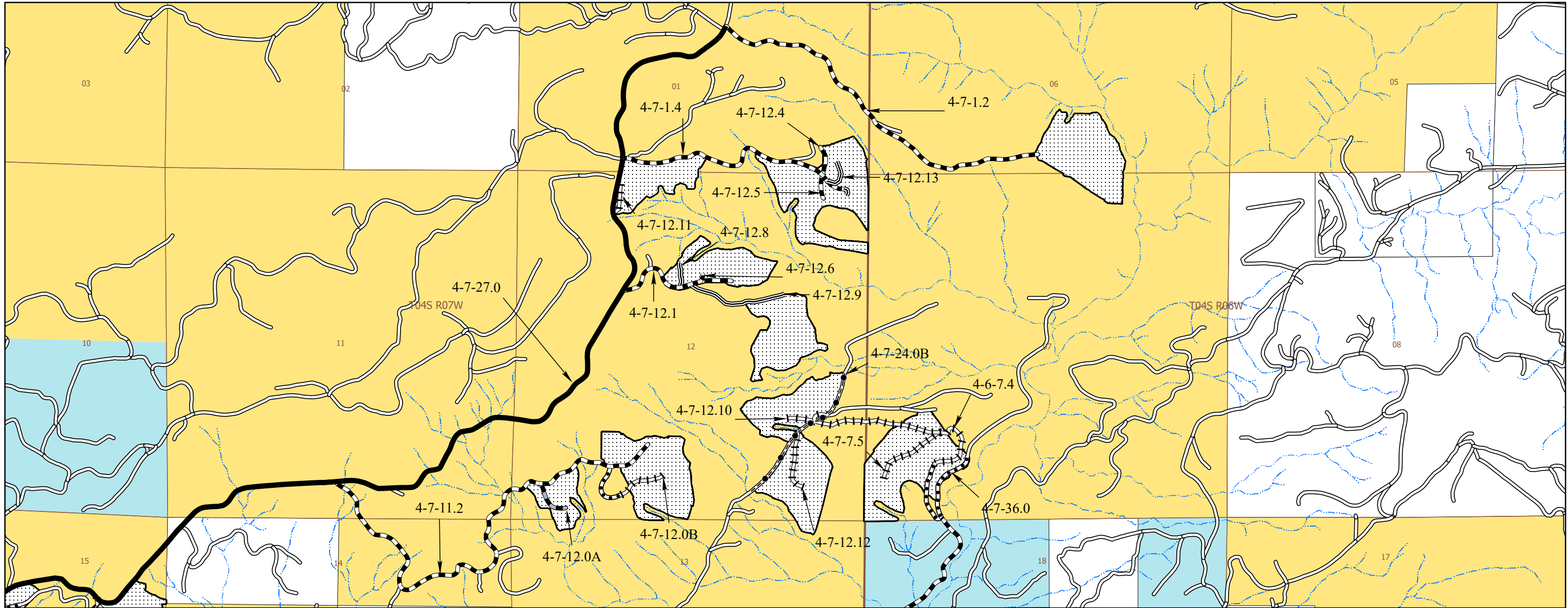

- | | |
|---|-----------------------------|
| Rocked surfaced road to be constructed, Decommission after use | Existing Roads |
| Natural surfaced road to be constructed, Decommission after use | Streams |
| Paved surfaced road to be maintained, Open after use | Coastal Chrome Project Area |
| Rocked surfaced road to be renovated, Decommission after use | Bureau of Land Management |
| Rocked surfaced road to be renovated, Open after use | State |
| Rocked surfaced road to be renovated, Stabilize after use | Private |
| Natural surfaced road to be renovated, Decommission after use | |

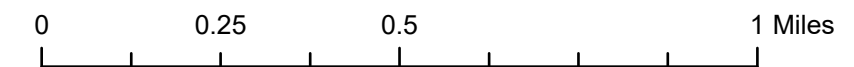

**United States Department of Interior
BUREAU OF LAND MANAGEMENT
NORTHWEST OREGON DISTRICT - OREGON
Road Plan Map**

Coastal Chrome Timber Sale
Contract NO ORN04-TS-2023-0402
Exhibit C
Page 47 of 78

T. 04S. R. 07W. Sections 1, 12, 13, 14, 15, 23, & 24 W.M. - NORTHWEST OREGON DISTRICT - OREGON
T. 04S. R. 06W Sections 6, 7, & 18 W.M. - NORTHWEST OREGON DISTRICT - OREGON
T. 05S. R. 07W. Sections 11 & 15 W.M. - NORTHWEST OREGON DISTRICT - OREGON

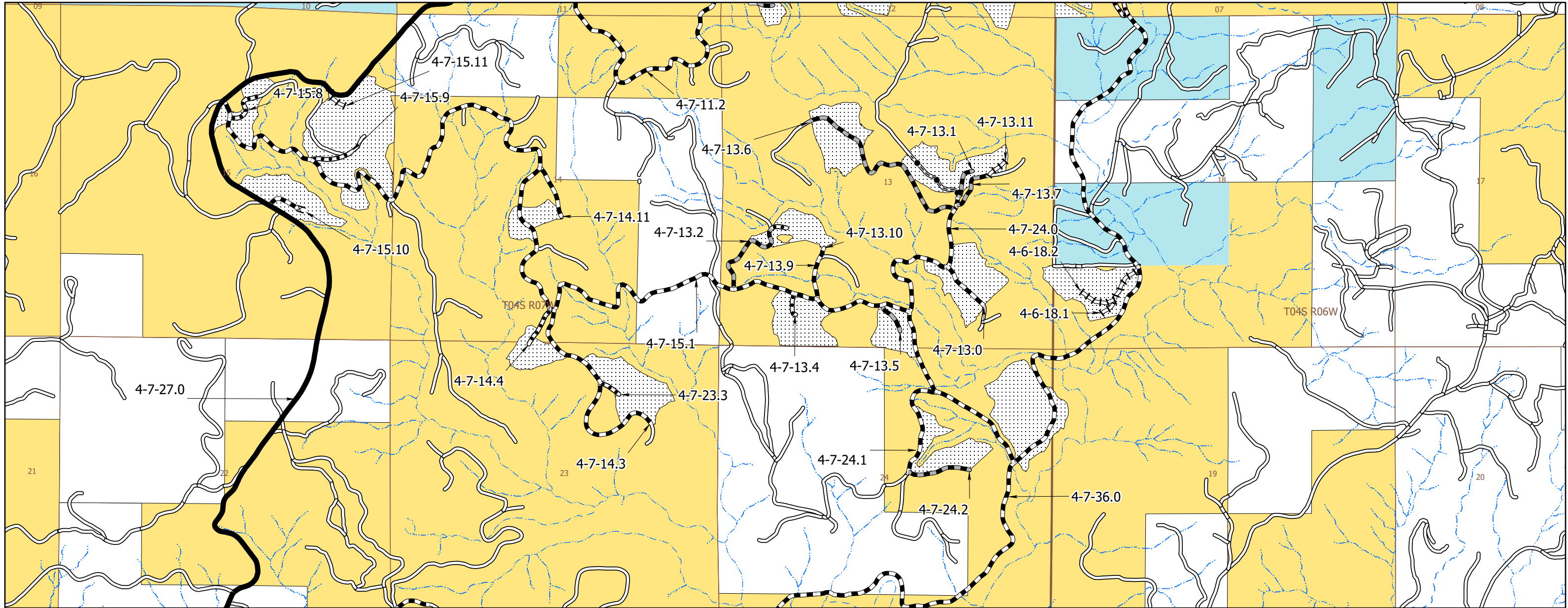

- | | |
|---|-----------------------------|
| Rocked surfaced road to be constructed, Decommission after use | Existing Roads |
| Natural surfaced road to be constructed, Decommission after use | Streams |
| Paved surfaced road to be maintained, Open after use | Coastal Chrome Project Area |
| Rocked surfaced road to be improved, Open after use | Bureau of Land Management |
| Rocked surfaced road to be renovated, Decommission after use | State |
| Rocked surfaced road to be renovated, Open after use | Private |
| Rocked surfaced road to be renovated, Stabilize after use | |
| Natural surfaced road to be renovated, Decommission after use | |

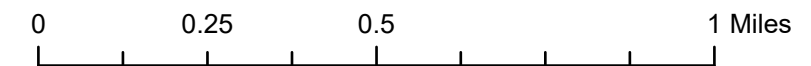

No warranty is made by the Bureau of Land Management as to the accuracy, reliability, or completeness of these data for individual or aggregate use with other data. Original data were compiled from various sources and may be updated without notification.
Prepared By: Austin Bettis

**United States Department of Interior
BUREAU OF LAND MANAGEMENT
NORTHWEST OREGON DISTRICT - OREGON
Road Plan Map**

T. 04S. R. 07W. Sections 1, 12, 13, 14, 15, 23, & 24 W.M. - NORTHWEST OREGON DISTRICT - OREGON
T. 04S. R. 06W Sections 6, 7, & 18 W.M. - NORTHWEST OREGON DISTRICT - OREGON
T. 05S. R. 07W. Sections 11 & 15 W.M. - NORTHWEST OREGON DISTRICT - OREGON

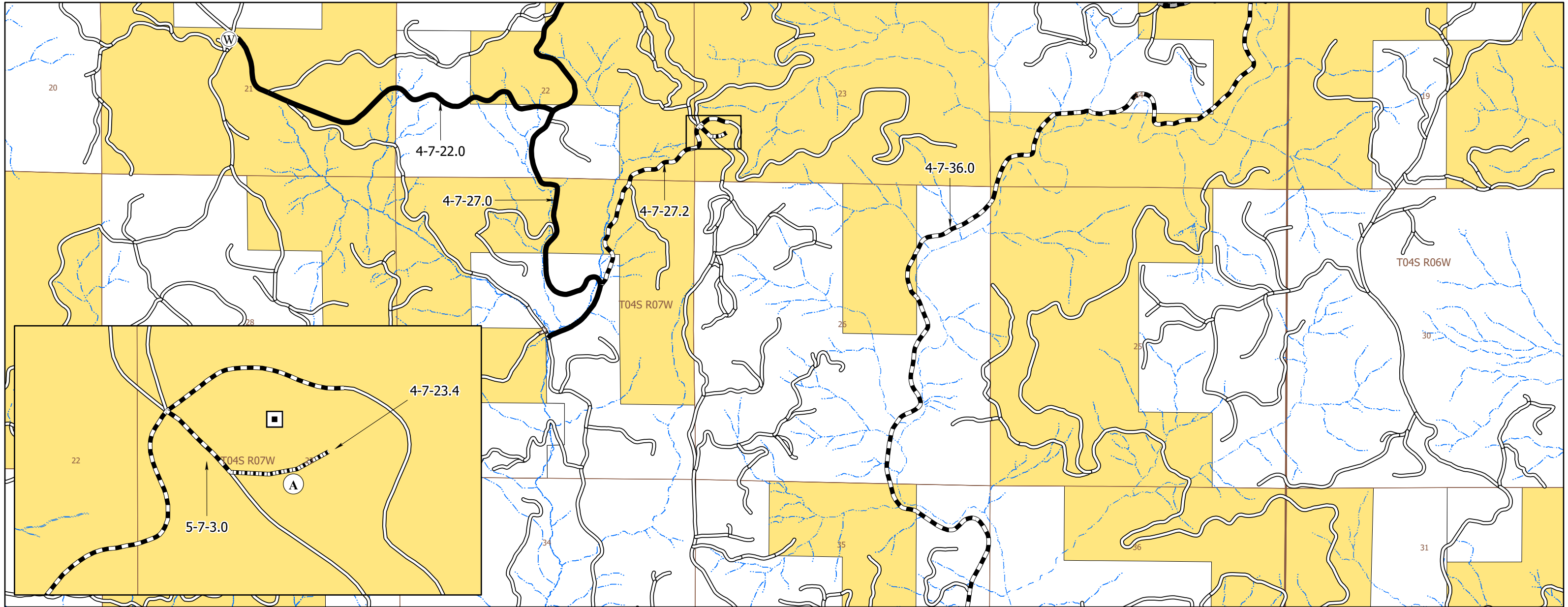

- Rocked surfaced road to be constructed, Decommission after use
- Paved surfaced road to be maintained, Open after use
- Rocked surfaced road to be renovated, Open after use
- Rocked surfaced road to be renovated, Stabilize after use
- Existing Roads
- Streams
- Whip Up Flats Quarry
- Coastal Chrome Project Area
- Bureau of Land Management
- State
- Private
- Water Source

Stockpile Sites - A, B, C

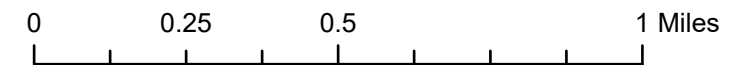

**United States Department of Interior
BUREAU OF LAND MANAGEMENT
NORTHWEST OREGON DISTRICT - OREGON
Road Plan Map**

T. 04S. R. 07W. Sections 1, 12, 13, 14, 15, 23, & 24 W.M. - NORTHWEST OREGON DISTRICT - OREGON
T. 04S. R. 06W Sections 6, 7, & 18 W.M. - NORTHWEST OREGON DISTRICT - OREGON
T. 05S. R. 07W. Sections 11 & 15 W.M. - NORTHWEST OREGON DISTRICT - OREGON

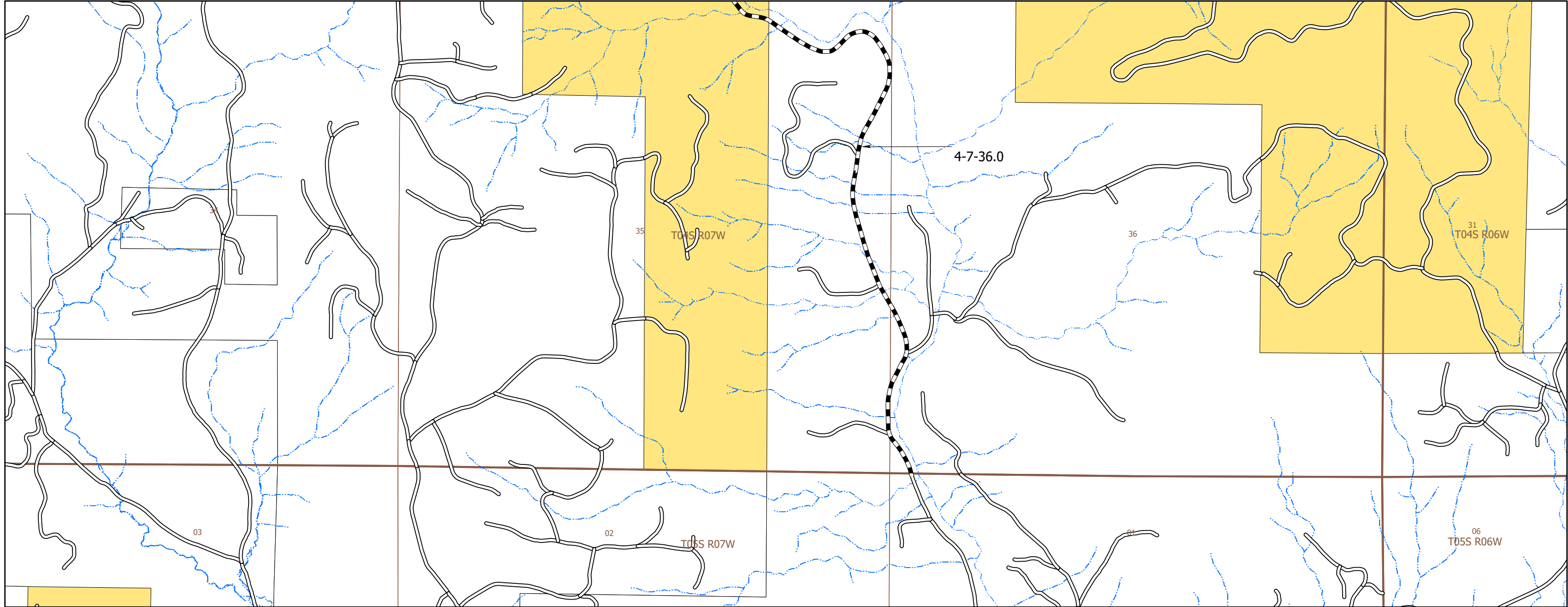

- Rocked surfaced road to be renovated, Open after use
- Existing Roads
- Streams
- Bureau of Land Management
- State
- Private

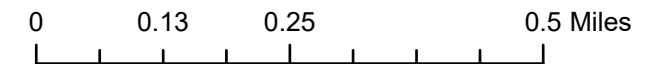

**United States Department of Interior
BUREAU OF LAND MANAGEMENT
NORTHWEST OREGON DISTRICT - OREGON
Road Plan Map**

T. 04S. R. 07W. Sections 1, 12, 13, 14, 15, 23, & 24 W.M. - NORTHWEST OREGON DISTRICT - OREGON
T. 04S. R. 06W Sections 6, 7, & 18 W.M. - NORTHWEST OREGON DISTRICT - OREGON
T. 05S. R. 07W. Sections 11 & 15 W.M. - NORTHWEST OREGON DISTRICT - OREGON

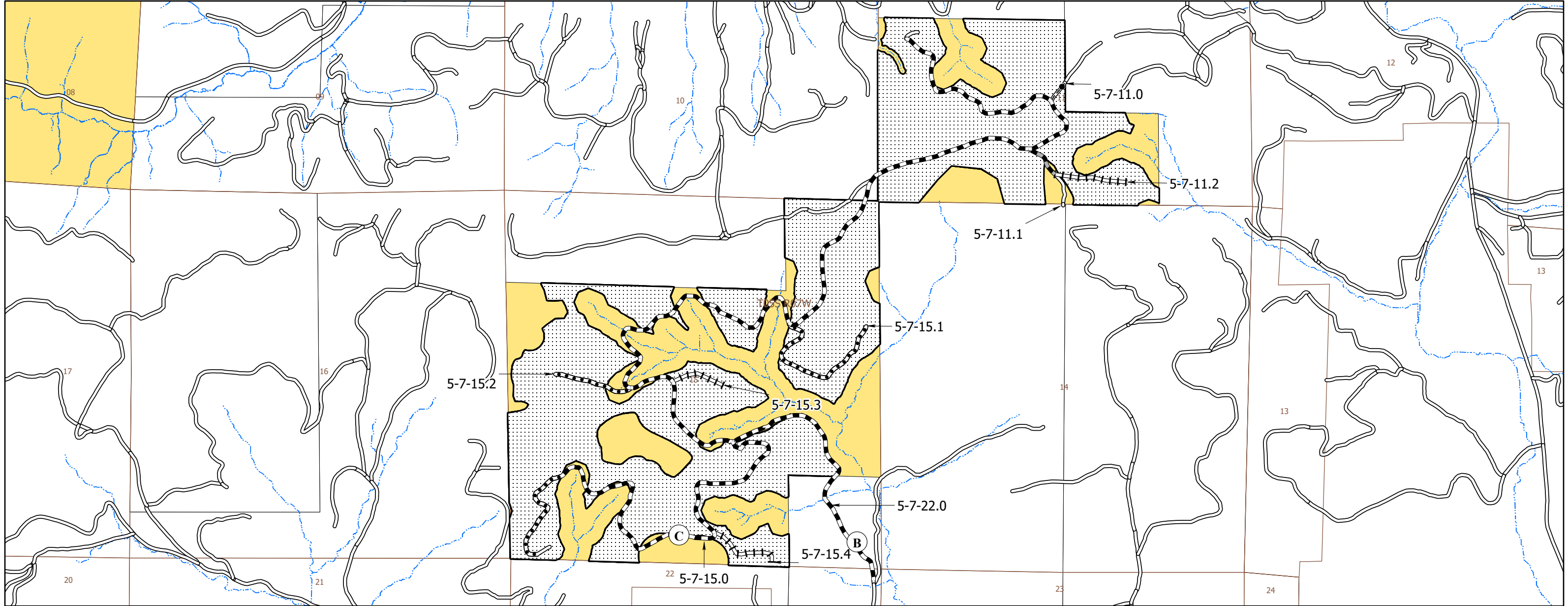

- | | |
|---|-------------------------------|
| ⚡ Natural surfaced road to be constructed, Decommission after use | — Streams |
| ●- - Rocked surfaced road to be renovated, Decommission after use | ▨ Coastal Chrome Project Area |
| ▬ Rocked surfaced road to be renovated, Open after use | ■ Bureau of Land Management |
| ▬ Rocked surfaced road to be renovated, Stabilize after use | ■ State |
| ▬ Natrual surfaced road to be renovated, Decommission after use | □ Private |
| — Existing Roads | |
- Stockpile Sites - A, B, C

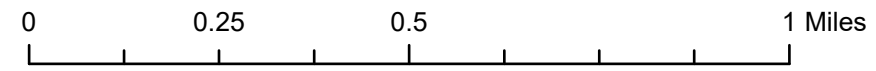

No warranty is made by the Bureau of Land Management as to the accuracy, reliability, or completeness of these data for individual or aggregate use with other data. Original data were compiled from various sources and may be updated without notification.
Prepared By: Austin Bettis

U.S. DEPT. OF THE INTERIOR
Bureau of Land Management

NORTHWEST OREGON DISTRICT OFFICE - OREGON

Earth Barricade, Waterdip, Drivable and Non-Drivable Waterbar Details

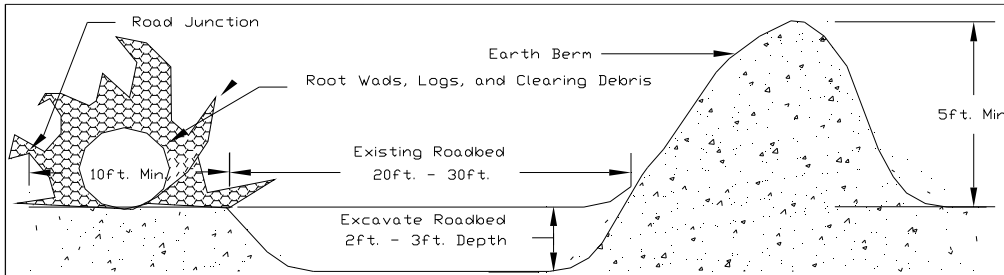

EARTH BARRICADE CONSTRUCTION

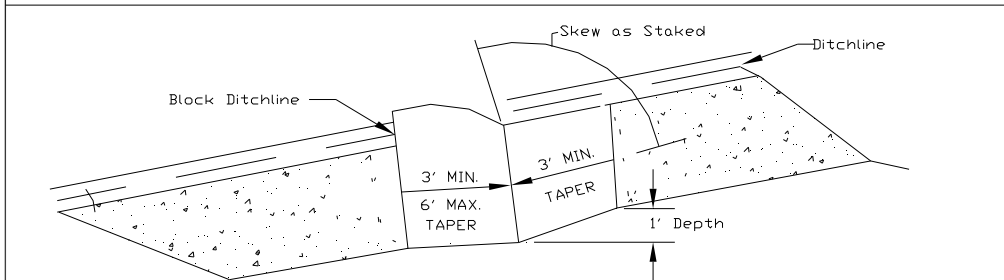

DRIVABLE WATERBAR CONSTRUCTION

- NOTE:
1. DITCHLINE IS TO BE BLOCKED WITH EXCAVATED MATERIAL TO PREVENT DITCH WATER FROM BYPASSING WATERBAR.
 2. EXCESS MATERIAL SHALL BE UNIFORMLY SPREAD ALONG ROADWAY. NO MATERIAL WILL BE ALLOWED BEYOND THE OUTER ROAD EDGE.

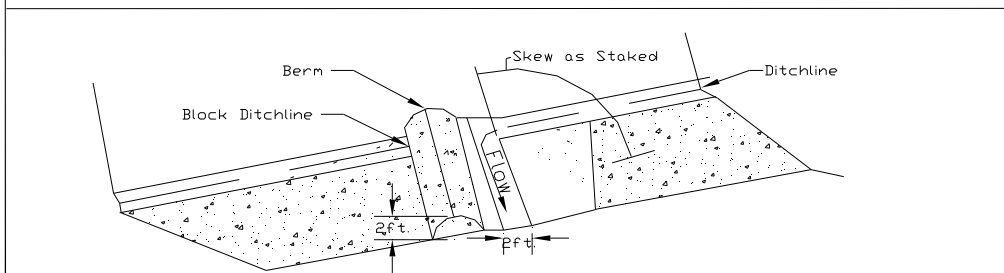

NON-DRIVABLE WATERBAR CONSTRUCTION

WATER DIP DETAIL

Not to Scale

NOTE: PLAN OF DIP SHOWN IS FOR OUTSLOPED ROLLING DIP, DIPS MAY BE EITHER INSLOPED OR OUTSLOPED. WHEN INSLOPED, DIPS SHALL DISCHARGE INTO A CULVERT, DROP INLET, OR OVERSIDE DRAIN, OR DRAINAGE DITCH. WHEN OUTSLOPED, THEY SHALL DISCHARGE INTO AN OVERSIDE DRAIN OR ON TO NATURAL GROUND. THE MINIMUM CROSS GRADE FROM "B" TO "E" IS 4% GREATER THAN THE ORIGINAL ROAD GRADE. SKEW LINE B-E TO FIT LOW POINT IN DRAW, IF LOCATED IN NATURAL DRAIN.

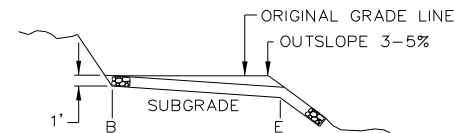
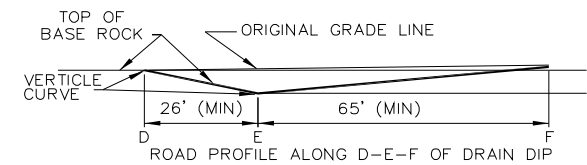
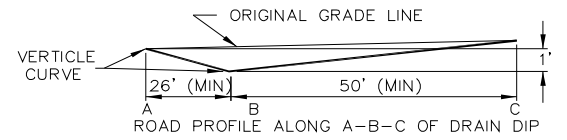
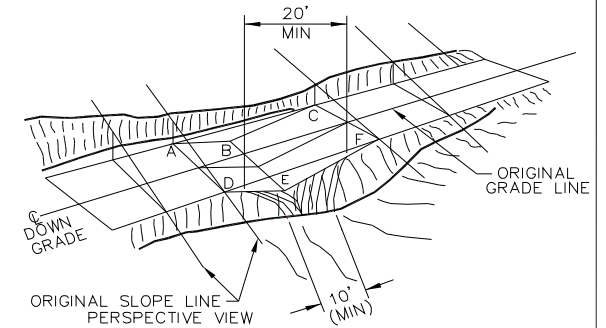

ROCK SPILL APRON 15' WIDE WITH MATERIAL AS SHOWN ON SCHEDULE OF ITEMS TO TOE OF FILL.

U.S. DEPT. OF THE INTERIOR
 Bureau of Land Management
 NORTHWEST OREGON DISTRICT OFFICE - OREGON

BRUSHING DETAILS

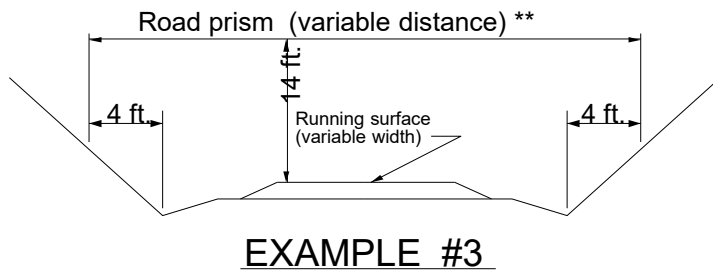
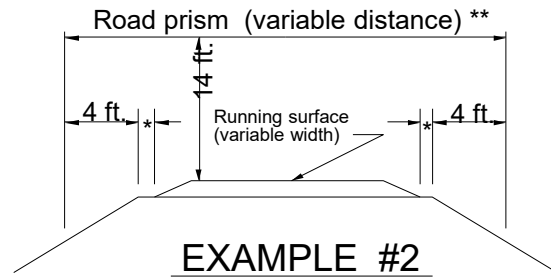
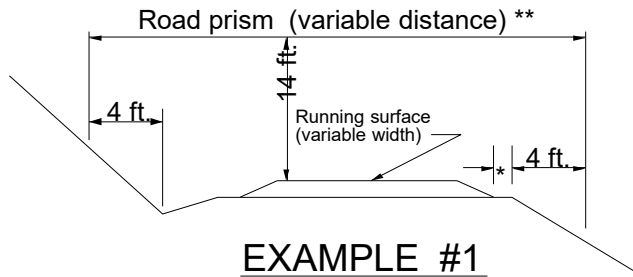

(NO SCALE)

- * Variable distance between running surface and start of fill slope
- ** All areas within the variable distance shall be free of all vegetation capable of growing one (1) foot in height or higher and all overhanging limbs and branches 14 feet in elevation above the running surface

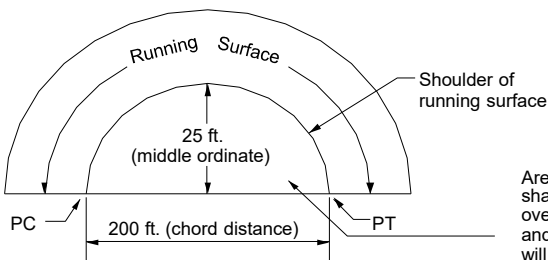

SIGHT DISTANCE DIAGRAM

Area to be cut: shall be free of overhanging limbs and all vegetation will be cut to a maximum height of one (1) foot.

U.S. DEPT. OF THE INTERIOR
Bureau of Land Management
NORTHWEST OREGON DISTRICT OFFICE - OREGON
Sediment Catch Basin with Straw Bale Details

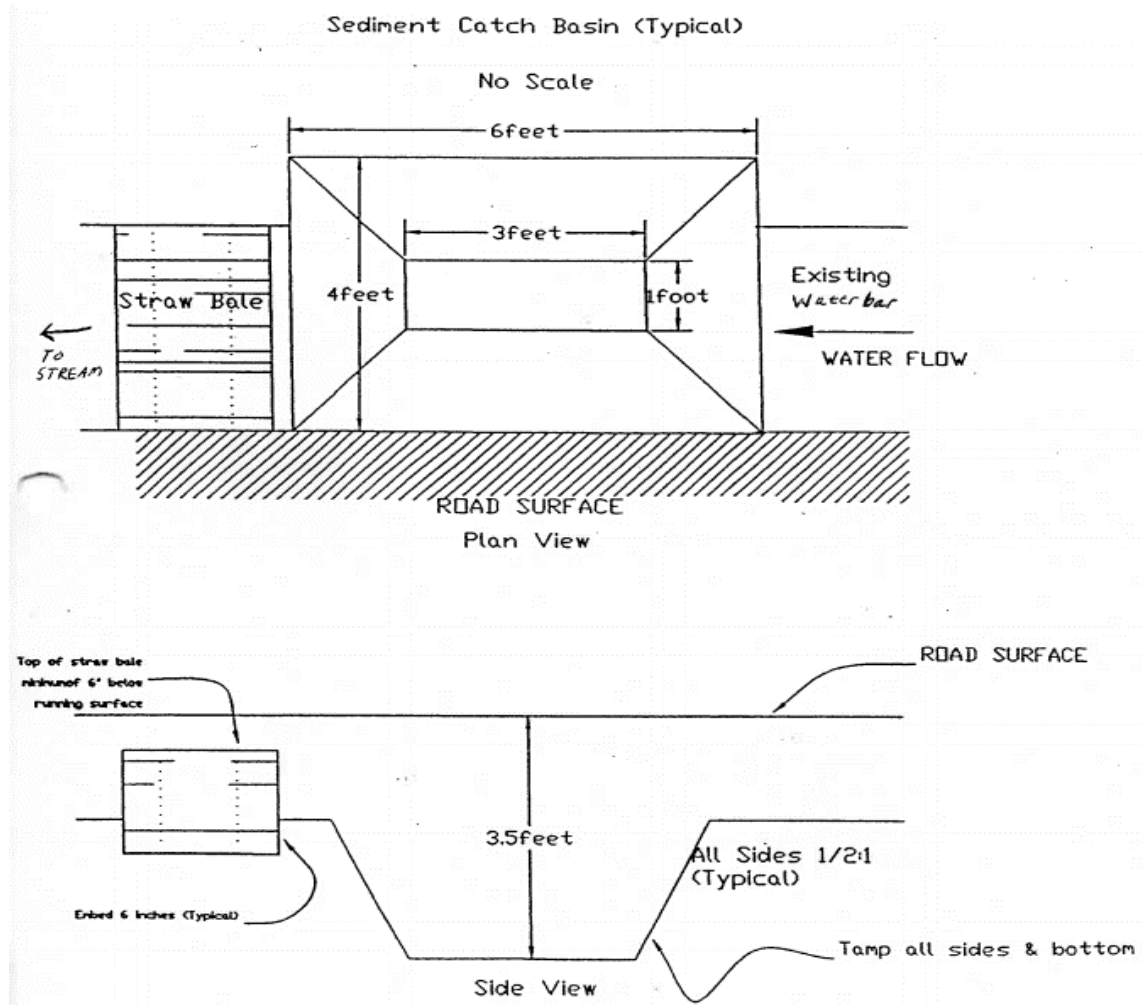

Culvert List

CULVERT LOCATIONS							DOWNSPOUT(d) or STANDPIPE(s) *4				ROCK			REMARKS *6			
DESIGNED *2											AS BUILT						
Road #	Sta./ M.P	SIZE	GAGE	LENGTH	CULVERT GRADE	INSTALL TYPE *3	SIZE	TYPE	LENGTH	TYPE OF ELBOW *5	SIZE	GAGE	LENGTH		RIP RAP (GRADING)		Structure inside pipe
														(a)	(b)		
4-6-7.4	6+09	24"	--	50'	--	--	--	--	--	--	--	--	--	--	--	--	Ephemeral Stream. Install Culvert as marked in the field and directed by Authorized Officer. Place 20 CY 1-1/2"-0" Crushed Bedding/Backfill Rock. Spread 20 CY 6" Jaw Run Base Rock over Pipe for Surfacing, capped with 15 CY 1-1/2"-0" Crushed Rock as marked. Install metal inlet marker.
	8+48	18"	--	35'	--	--	18"	1	10'	--	--	--	--	--	--	--	Install Culvert and downspout as marked in the field and directed by Authorized Officer. Place 15 CY 1-1/2"-0" Crushed Bedding/Backfill Rock. Spread 15 CY 6" Jaw Run Base Rock over Pipe for Surfacing, capped with 10 CY 1-1/2"-0" Crushed Rock as marked. Install metal inlet marker.
	14+30	18"	--	35'	--	--	--	--	--	--	--	--	--	--	--	--	Install Culvert as marked in the field and directed by Authorized Officer. Place 15 CY 1-1/2"-0" Crushed Bedding/Backfill Rock. Spread 15 CY 6" Jaw Run Base Rock over Pipe for Surfacing, capped with 10 CY 1-1/2"-0" Crushed Rock as marked. Install metal inlet marker.
	21+69	18"	--	40'	--	--	--	--	--	--	--	--	--	--	--	--	Install Culvert as marked in field and directed by Authorized Officer. Place 20 CY 1-1/2"-0" Crushed Bedding/Backfill Rock. Spread 20 CY 6" Jaw Run Base Rock over Pipe for Surfacing, capped with 15 CY 1-1/2"-0" Crushed Rock as marked. Install metal inlet marker.
	25+17	18"	--	35'	--	--	--	--	--	--	--	--	--	--	--	--	Install Culvert as marked in the field and directed by Authorized Officer. Place 15 CY 1-1/2"-0" Crushed Bedding/Backfill Rock. Spread 15 CY 6" Jaw Run Base Rock over Pipe for Surfacing, capped with 10 CY 1-1/2"-0" Crushed Rock as marked. Install metal inlet marker.
	27+30	18"	--	40'	--	--	--	--	--	--	--	--	--	--	--	--	Install Culvert as marked in field and directed by Authorized Officer. Place 20 CY 1-1/2"-0" Crushed Bedding/Backfill Rock. Spread 20 CY 6" Jaw Run Base Rock over Pipe for Surfacing, capped with 15 CY 1-1/2"-0" Crushed Rock as marked. Install metal inlet marker.
	32+12	18"	--	45'	--	--	--	--	--	--	--	--	--	--	--	--	Install Culvert as marked in field and directed by Authorized Officer. Place 20 CY 1-1/2"-0" Crushed Bedding/Backfill Rock. Spread 20 CY 6" Jaw Run Base Rock over Pipe for Surfacing, capped with 15 CY 1-1/2"-0" Crushed Rock as marked. Install metal inlet marker.
	34+77	18"	--	40'	--	--	--	--	--	--	--	--	--	--	--	--	Install Culvert as marked in field and directed by Authorized Officer. Place 20 CY 1-1/2"-0" Crushed Bedding/Backfill Rock. Spread 20 CY 6" Jaw Run Base Rock over Pipe for Surfacing, capped with 15 CY 1-1/2"-0" Crushed Rock as marked. Install metal inlet marker.
	37+82	18"	--	40'	--	--	--	--	--	--	--	--	--	--	--	--	Install Culvert as marked in field and directed by Authorized Officer. Place 20 CY 1-1/2"-0" Crushed Bedding/Backfill Rock. Spread 20 CY 6" Jaw Run Base Rock over Pipe for Surfacing, capped with 15 CY 1-1/2"-0" Crushed Rock as marked. Install metal inlet marker.
4-7-1.2	4+61	18"	--	35'	--	--	--	--	--	--	--	--	--	5	--	--	Replace Existing Culvert as marked in the field and directed by Authorized Officer. Place 15 CY 1-1/2"-0" Crushed Bedding/Backfill Rock. Spread 10 CY 1-1/2"-0" Crushed Cap Rock over 3"-0" Crushed lift. Place 5 CY Class 5 RipRap as energy dissipater at outlet. Install metal inlet marker.
	7+92	18"	--	35'	--	--	--	--	--	--	--	--	--	--	--	--	Replace Existing Culvert as marked in the field and directed by Authorized Officer. Place 15 CY 1-1/2"-0" Crushed Bedding/Backfill Rock. Spread 10 CY 1-1/2"-0" Crushed Cap Rock over 3"-0" Crushed lift. Install metal inlet marker.
	10+07	--	--	--	--	--	--	--	--	--	--	--	--	--	--	--	Install metal inlet marker on existing CMP.
	13+43	18"	--	35'	--	--	--	--	--	--	--	--	--	--	--	--	Replace Existing Culvert as marked in the field and directed by Authorized Officer. Place 15 CY 1-1/2"-0" Crushed Bedding/Backfill Rock. Spread 10 CY 1-1/2"-0" Crushed Cap Rock over 3"-0" Crushed lift. Install metal inlet marker.
	14+76	18"	--	35'	--	--	--	--	--	--	--	--	--	--	--	--	Replace Existing Culvert as marked in the field and directed by Authorized Officer (outlet shall be installed 1' lower than existing). Place 15 CY 1-1/2"-0" Crushed Bedding/Backfill Rock. Spread 10 CY 1-1/2"-0" Crushed Cap Rock over 3"-0" Crushed lift. Install metal inlet marker.
	16+35	18"	--	35'	--	--	--	--	--	--	--	--	--	--	--	--	Replace Existing Culvert as marked in the field and directed by Authorized Officer. Place 15 CY 1-1/2"-0" Crushed Bedding/Backfill Rock. Spread 10 CY 1-1/2"-0" Crushed Cap Rock over 3"-0" Crushed lift. Install metal inlet marker.
	25+12	--	--	--	--	--	18"	2	20'	--	--	--	--	--	--	--	Remove damaged half-round downspout and replace with an 18" x 20' Metal Half-Round downspout. Install metal inlet marker.
	29+55	18"	--	30'	--	--	18"	1	20'	--	--	--	--	--	--	--	Replace Existing Culvert and downspout as marked in the field and directed by Authorized Officer. Place 10 CY 1-1/2"-0" Crushed Bedding/Backfill Rock. Spread 10 CY 1-1/2"-0" Crushed Cap Rock over 3"-0" Crushed lift. Install metal inlet marker.
	35+16	18"	--	35'	--	--	18"	1	20'	--	--	--	--	--	--	--	Replace Existing Culvert and downspout as marked in the field and directed by Authorized Officer (Approx. 7' fill @ CL). Place 15 CY 1-1/2"-0" Crushed Bedding/Backfill Rock. Spread 10 CY 1-1/2"-0" Crushed Cap Rock over 3"-0" Crushed lift. Install metal inlet marker.
	41+76	--	--	--	--	--	18"	2	20'	--	--	--	--	--	--	--	Install an 18" x 20' Metal Half-Round downspout. Install metal inlet marker.
	46+47	--	--	--	--	--	--	--	--	--	--	--	--	--	--	--	Install metal inlet marker on existing CMP. Clean buried inlet and outlet of existing CMP.

Gage Chart		
Gage	Dec. Inches	
	Steel	Alum.
10	.138	.135
12	.109	.105
14	.079	.075
16	.064	.060

1. Designed culvert lengths and locations are approximate.

*2. all culverts have 2-2/3" x 1/2"

unless otherwise noted.

**** Corrugated plastic pipe (CPP), Type S (double wall) shall be used for culvert sizes 24" and smaller. All larger culverts shall be aluminized steel. All aluminized steel culverts are to have hugger type bands and neoprene gaskets. Culverts 20' in length or smaller shall be one piece (no joints). No Culvert piece shall be shorter than 6 foot. Minimization of banding is required.

*4. Downspout or Standpipe Types

- 1) Full *** Downspouts and stand pipes (under 36" diameter) shall be CPP, Type C (single wall); unless otherwise specified.
- 2) Half
- 3) Flume

*5. 1) Conventional or Fabricated

- 2) Turner type
- 3) Slip joint

*6. Include special sections, structures, headwalls, footings & other data.

Culvert List

CULVERT LOCATIONS							DOWNSPOUT(d) or STANDPIPE(s) *4				AS BUILT			ROCK			REMARKS *6
DESIGNED *2														RIP RAP (GRADING)			
Road #	Sta./ M.P	SIZE	GAGE	LENGTH	CULVERT GRADE	INSTALL TYPE *3	SIZE	TYPE	LENGTH	TYPE OF ELBOW *5	SIZE	GAGE	LENGTH	INLET	OUTLET	Structure inside pipe	
4-7-1.4/ Eastline Quarry Rd.	0.000	18"	--	60'	--	--	--	--	--	--	--	--	--	--	--	--	Install Culvert in existing ditchline as marked in the field and directed by Authorized Officer. Place 25 CY 1-1/2"-0" Crushed Bedding/Backfill Rock. Spread 20 CY 6" Jaw Run Base Rock over Pipe for Surfacing, capped with 20 CY 3/4"-0" Crushed Rock as marked. Cut/remove bituminous surfacing over culvert location and replace with 3.7 tons (approx. 4" lift) bituminous surfacing when Base/Cap Rock has been approved by Authorized Officer . Asphalt approach is 50' wide .
	0.141	18"	--	40'	--	--	--	--	--	--	--	--	--	--	--	--	Replace Existing Culvert as marked in the field and directed by Authorized Officer. Place 20 CY 1-1/2"-0" Crushed Bedding/Backfill Rock. Spread 20 CY 6" Jaw Run Base Rock capped with lift of crushed over Pipe for Surfacing as marked. Install metal inlet marker.
	0.193	18"	--	45'	--	--	--	--	--	--	--	--	--	--	--	--	Install Culvert as marked in the field and directed by Authorized Officer. Place 25 CY 1-1/2"-0" Crushed Bedding/Backfill Rock. Spread 20 CY 6" Jaw Run Base Rock capped with lift of crushed over Pipe for Surfacing as marked. Install metal inlet marker.
	0.297	18"	--	40'	--	--	--	--	--	--	--	--	--	--	--	--	Replace Existing Culvert as marked in the field and directed by Authorized Officer. Place 20 CY 1-1/2"-0" Crushed Bedding/Backfill Rock. Spread 20 CY 6" Jaw Run Base Rock capped with lift of crushed over Pipe for Surfacing as marked. Install metal inlet marker.
	0.358	24"	--	60'	--	--	--	--	--	--	--	--	--	10	60	--	Stream Crossing. Replace Existing Culvert as marked in field and directed by Authorized Officer (approx. 12' fill @ CL). Place 25 CY 1-1/2"-0" Crushed Bedding/Backfill Rock. Spread 20 CY 6" Jaw Run Base Rock capped with lift of crushed over Pipe for Surfacing as marked. Place 10 CY Class 5 RipRap @ inlet as fill armor. Place 60 CY Class 5 RipRap @ outlet as fill armor/energy dissipater. Install metal inlet marker.
	0.410	18"	--	40'	--	--	--	--	--	--	--	--	--	--	--	--	Replace Existing Culvert as marked in the field and directed by Authorized Officer (Approx. 6' fill @ CL). Place 20 CY 1-1/2"-0" Crushed Bedding/Backfill Rock. Spread 20 CY 6" Jaw Run Base Rock capped with lift of crushed over Pipe for Surfacing as marked. Install metal inlet marker.
	0.481	18"	--	30'	--	--	--	--	--	--	--	--	--	--	--	--	Replace Existing Culvert as marked in the field and directed by Authorized Officer. Place 10 CY 1-1/2"-0" Crushed Bedding/Backfill Rock. Spread 10 CY 6" Jaw Run Base Rock capped with lift of crushed over Pipe for Surfacing as marked.
	0.525	18"	--	30'	--	--	--	--	--	--	--	--	--	--	--	--	Replace Existing Culvert as marked in the field and directed by Authorized Officer. Place 10 CY 1-1/2"-0" Crushed Bedding/Backfill Rock. Spread 10 CY 6" Jaw Run Base Rock capped with lift of crushed over Pipe for Surfacing as marked. Install metal inlet marker.
	0.553	18"	--	30'	--	--	--	--	--	--	--	--	--	--	--	--	Replace Existing Culvert as marked in the field and directed by Authorized Officer. Place 10 CY 1-1/2"-0" Crushed Bedding/Backfill Rock. Spread 10 CY 6" Jaw Run Base Rock capped with lift of crushed over Pipe for Surfacing as marked.
4-7-11.2/ Bell Mntn. Ext. Rd.	0.021	24"	--	30'	--	--	--	--	--	--	--	--	--	--	--	--	Stream Crossing. Replace Existing Culvert as marked in field and directed by Authorized Officer (approx. 4' fill @ CL). Place 15 CY 1-1/2"-0" Crushed Bedding/Backfill Rock. Spread 15 CY 6" Jaw Run Base Rock over Pipe as Surfacing capped with 10 CY 1-1/2"-0" Crushed as marked. Install metal inlet marker.
	0.036	24"	--	40'	--	--	--	--	--	--	--	--	--	--	--	--	Stream Crossing. Replace Existing Culvert as marked in field and directed by Authorized Officer (approx. 5' fill @ CL). Place 20 CY 1-1/2"-0" Crushed Bedding/Backfill Rock. Spread 20 CY 6" Jaw Run Base Rock over Pipe as Surfacing capped with 15 CY 1-1/2"-0" Crushed as marked. Install metal inlet marker.
	0.071	24"	--	40'	--	--	--	--	--	--	--	--	--	5	15	--	Stream Crossing. Replace Existing Culvert as marked in field and directed by Authorized Officer (approx. 6.5' fill @ CL). Place 20 CY 1-1/2"-0" Crushed Bedding/Backfill Rock. Spread 20 CY 6" Jaw Run Base Rock over Pipe as Surfacing capped with 15 CY 1-1/2"-0" Crushed as marked. Place 5 CY Class 5 RipRap @ Inlet as Fill Armor. Place 15 CY Class 5 RipRap @ outlet as Fill Armor. Install metal inlet marker.
	0.150	--	--	--	--	--	--	--	--	--	--	--	--	--	--	--	Install metal inlet marker on existing CMP.
	0.243	18"	--	35'	--	--	--	--	--	--	--	--	--	--	--	--	Install Culvert as marked in field and directed by Authorized Officer. Place 15 CY 1-1/2"-0" Crushed Bedding/Backfill Rock. Spread 15 CY 6" Jaw Run Base Rock over Pipe as Surfacing capped with 10 CY 1-1/2"-0" Crushed as marked. Install metal inlet marker.
	0.260	24"	--	40'	--	--	--	--	--	--	--	--	--	--	10	--	Stream Crossing. Replace Existing Culvert as marked in field and directed by Authorized Officer (approx. 7' fill @ CL). Place 20 CY 1-1/2"-0" Crushed Bedding/Backfill Rock. Spread 20 CY 6" Jaw Run Base Rock over Pipe as Surfacing capped with 15 CY 1-1/2"-0" Crushed as marked. Place 10 CY Class 5 RipRap @ outlet as Fill Armor. Install metal inlet marker.
	0.292	24"	--	40'	--	--	--	--	--	--	--	--	--	5	15	--	Stream Crossing. Replace Existing Culvert as marked in field and directed by Authorized Officer (approx. 6.5' fill @ CL). Place 20 CY 1-1/2"-0" Crushed Bedding/Backfill Rock. Spread 20 CY 6" Jaw Run Base Rock over Pipe as Surfacing capped with 15 CY 1-1/2"-0" Crushed as marked. Place 5 CY Class 5 RipRap @ Inlet as Fill Armor. Place 15 CY Class 5 RipRap @ outlet as Fill Armor. Install metal inlet marker.
	0.423	--	--	--	--	--	--	--	--	--	--	--	--	--	--	--	Install metal inlet marker on existing CMP.
	0.545	24"	--	60'	--	--	--	--	--	--	--	--	--	10	40	--	Stream Crossing. Replace Existing Culvert as marked in field and directed by Authorized Officer (approx. 11.5' fill @ CL). Place 25 CY 1-1/2"-0" Crushed Bedding/Backfill Rock. Spread 20 CY 6" Jaw Run Base Rock over Pipe as Surfacing capped with 15 CY 1-1/2"-0" Crushed as marked. Place 10 CY Class 5 RipRap @ Inlet as Fill Armor. Place 40 CY Class 5 RipRap @ outlet as Fill Armor. Install metal inlet marker.
	0.723	24"	--	30'	--	--	--	--	--	--	--	--	--	5	15	--	Stream Crossing. Replace Existing Culvert as marked in field and directed by Authorized Officer (approx. 4.5' fill @ CL). Place 15 CY 1-1/2"-0" Crushed Bedding/Backfill Rock. Spread 15 CY 6" Jaw Run Base Rock over Pipe as Surfacing capped with 10 CY 1-1/2"-0" Crushed as marked. Place 5 CY Class 5 RipRap @ Inlet as Fill Armor. Place 15 CY Class 5 RipRap @ outlet as Fill Armor. Install metal inlet marker.
	0.787	18"	--	30'	--	--	--	--	--	--	--	--	--	--	--	--	Replace Existing Culvert as marked in field and directed by Authorized Officer. Place 10 CY 1-1/2"-0" Crushed Bedding/Backfill Rock. Spread 10 CY 6" Jaw Run Base Rock over Pipe as Surfacing capped with 10 CY 1-1/2"-0" Crushed as marked. Install metal inlet marker.
	0.880	24"	--	50'	--	--	--	--	--	--	--	--	--	10	20	--	Stream Crossing. Replace Existing Culvert as marked in field and directed by Authorized Officer (approx. 9.5' fill @ CL). Place 20 CY 1-1/2"-0" Crushed Bedding/Backfill Rock. Spread 20 CY 6" Jaw Run Base Rock over Pipe as Surfacing capped with 15 CY 1-1/2"-0" Crushed as marked. Place 10 CY Class 5 RipRap @ Inlet as Fill Armor. Place 20 CY Class 5 RipRap @ outlet as Fill Armor. Install metal inlet marker.

Gage Chart		
Gage	Dec. Inches	
	Steel	Alum.
10	.138	.135
12	.109	.105
14	.079	.075
16	.064	.060

1. Designed culvert lengths and locations are approximate.

*2. all culverts have 2-2/3" x 1/2"

unless otherwise noted.

**** Corrugated plastic pipe (CPP), Type S (double wall) shall be used for culvert sizes 24" and smaller. All larger culverts shall be aluminized steel. All aluminized steel culverts are to have hugger type bands and neoprene gaskets. Culverts 20' in length or smaller shall be one piece (no joints). No Culvert piece shall be shorter than 6 foot. Minimization of banding is required.

*4. Downspout or Standpipe Types

- 1) Full
- 2) Half
- 3) Flume

*** Downspouts and stand pipes (under 36" diameter) shall be CPP, Type C (single wall); unless otherwise specified.

*5. 1) Conventional or Fabricated
2) Turner type
3) Slip joint

*6. Include special sections, structures, headwalls, footings & other data.

Culvert List

CULVERT LOCATIONS							DOWNSPOUT(d) or STANDPIPE(s) *4				AS BUILT			ROCK			REMARKS *6
DESIGNED *2														RIP RAP (GRADING)			
Road #	Sta./ M.P	SIZE	GAGE	LENGTH	CULVERT GRADE	INSTALL TYPE *3	SIZE	TYPE	LENGTH	TYPE OF ELBOW *5	SIZE	GAGE	LENGTH	INLET	OUTLET	Structure inside pipe	
4-7-11.2/ Bell Mntn. Ext. Rd. (cont.)	0.984	--	--	--	--	--	--	--	--	--	--	--	--	--	--	--	Install metal inlet marker on existing CMP.
	1.082	36"	14	70'	--	--	--	--	--	--	--	--	--	20	40	--	Stream Crossing. Replace Existing Culvert as marked in field and directed by Authorized Officer (approx. 14.5' fill @ CL). Place 40 CY 1-1/2"-0" Crushed Bedding/Backfill Rock. Spread 30 CY 6" Jaw Run Base Rock over Pipe as Surfacing capped with 20 CY 1-1/2"-0" Crushed as marked. Place 20 CY Class 5 RipRap @ Inlet as Fill Armor. Place 40 CY Class 5 RipRap @ outlet as Fill Armor/Energy Dissipater. Install metal inlet marker.
	1.129	24"	--	30'	--	--	--	--	--	--	--	--	--	--	--	--	Stream Crossing. Replace Existing Culvert as marked in field and directed by Authorized Officer (approx. 5' fill @ CL). Place 20 CY 1-1/2"-0" Crushed Bedding/Backfill Rock. Spread 20 CY 6" Jaw Run Base Rock over Pipe as Surfacing capped with 15 CY 1-1/2"-0" Crushed as marked. Install metal inlet marker.
	1.175	18"	--	30'	--	--	--	--	--	--	--	--	--	--	--	--	Install Culvert as marked in field and directed by Authorized Officer. Place 10 CY 1-1/2"-0" Crushed Bedding/Backfill Rock. Spread 10 CY 6" Jaw Run Base Rock over Pipe as Surfacing capped with 10 CY 1-1/2"-0" Crushed as marked. Install metal inlet marker.
	1.245	18"	--	30'	--	--	--	--	--	--	--	--	--	5	--	--	Replace Existing Culvert as marked in field and directed by Authorized Officer. Place 10 CY 1-1/2"-0" Crushed Bedding/Backfill Rock. Spread 10 CY 6" Jaw Run Base Rock over Pipe as Surfacing capped with 10 CY 1-1/2"-0" Crushed as marked. Place 5 CY Class 5 RipRap @ outlet as Energy Dissipater. Install metal inlet marker.
4-7-12.0A	2+96	--	--	--	--	--	--	--	--	--	--	--	--	--	--	--	Clean buried inlet and outlet of existing CMP.
4-7-12.0B	4+60	18"	--	35'	--	--	--	--	--	--	--	--	--	--	--	--	Install Culvert as marked in field and directed by Authorized Officer. Place 15 CY 1-1/2"-0" Crushed Bedding/Backfill Rock. Spread 15 CY 6" Jaw Run Base Rock over Pipe as Surfacing capped with 10 CY 1-1/2"-0" Crushed as marked. Install metal inlet marker.
	7+65	18"	--	50'	--	--	--	--	--	--	--	--	--	--	--	--	Install Culvert as marked in field and directed by Authorized Officer. Place 20 CY 1-1/2"-0" Crushed Bedding/Backfill Rock. Spread 20 CY 6" Jaw Run Base Rock over Pipe as Surfacing capped with 15 CY 1-1/2"-0" Crushed as marked. Install metal inlet marker.
	10+04	18"	--	40'	--	--	--	--	--	--	--	--	--	--	--	--	Install Culvert as marked in field and directed by Authorized Officer. Place 20 CY 1-1/2"-0" Crushed Bedding/Backfill Rock. Spread 20 CY 6" Jaw Run Base Rock over Pipe as Surfacing capped with 15 CY 1-1/2"-0" Crushed as marked. Install metal inlet marker.
4-7-12.1	0+22	18"	--	45'	--	--	--	--	--	--	--	--	--	--	--	--	Install Culvert in existing ditchline as marked in the field and directed by Authorized Officer. Place 20 CY 1-1/2"-0" Crushed Bedding/Backfill Rock. Spread 20 CY 6" Jaw Run Base Rock over Pipe for Surfacing, capped with 20 CY 3/4"-0" Crushed Rock as marked. Cut/remove bituminous surfacing over culvert and replace with 3.0 tons bituminous surfacing (approx. 4" lift) when Base/Cap Rock has been approved by Authorized Officer. Asphalt approach is 40' wide .
	9+52	18"	--	35'	--	--	--	--	--	--	--	--	--	--	--	--	Install Culvert as marked in the field and directed by Authorized Officer. Place 15 CY 1-1/2"-0" Crushed Bedding/Backfill Rock. Spread 10 CY 1-1/2"-0" Crushed Cap Rock over 3"-0" Crushed lift. Install metal inlet marker.
4-7-12.9	3+96	18"	--	35'	--	--	--	--	--	--	--	--	--	--	--	--	Install Culvert as marked in the field and directed by Authorized Officer. Place 15 CY 1-1/2"-0" Crushed Bedding/Backfill Rock. Surface with lifts of Base and Cap Rock. Install metal inlet marker.
	7+06	18"	--	35'	--	--	--	--	--	--	--	--	--	--	--	--	Install Culvert as marked in the field and directed by Authorized Officer. Place 15 CY 1-1/2"-0" Crushed Bedding/Backfill Rock. Surface with lifts of Base and Cap Rock. Install metal inlet marker.
	10+23	18"	--	35'	--	--	--	--	--	--	--	--	--	--	--	--	Install Culvert as marked in the field and directed by Authorized Officer. Place 15 CY 1-1/2"-0" Crushed Bedding/Backfill Rock. Surface with lifts of Base and Cap Rock. Install metal inlet marker.
4-7-13.2	3+73	18"	--	40'	--	--	--	--	--	--	--	--	--	--	--	--	Install Culvert as marked in field and directed by Authorized Officer (Approx. 4.5' fill @ CL). Place 20 CY 1-1/2"-0" Crushed Bedding/Backfill Rock. Spread 20 CY 6" Jaw Run Base Rock over Pipe as Surfacing capped with 15 CY 1-1/2"-0" Crushed as marked. Install metal inlet marker.
	8+52	18"	--	35'	--	--	--	--	--	--	--	--	--	--	--	--	Replace Existing Culvert as marked in field and directed by Authorized Officer. Place 15 CY 1-1/2"-0" Crushed Bedding/Backfill Rock. Spread 15 CY 6" Jaw Run Base Rock over Pipe as Surfacing capped with 10 CY 1-1/2"-0" Crushed as marked. Install metal inlet marker.
4-7-13.5	0+00	18"	--	60'	--	--	--	--	--	--	--	--	--	--	--	--	Replace Existing Culvert in existing ditchline as marked in field and directed by Authorized Officer. Place 25 CY 1-1/2"-0" Crushed Bedding/Backfill Rock. Spread 25 CY 6" Jaw Run Base Rock over Pipe as Surfacing capped with 20 CY 1-1/2"-0" Crushed as marked.
4-7-13.6	0.003	--	--	--	--	--	--	--	--	--	--	--	--	--	--	--	Clean buried inlet and outlet of existing CMP.
	0.042	--	--	--	--	--	--	--	--	--	--	--	--	--	--	--	Install metal inlet marker on existing CMP.
	0.135	--	--	--	--	--	--	--	--	--	--	--	--	--	--	--	Install metal inlet marker on existing CMP.
	0.238	--	--	--	--	--	--	--	--	--	--	--	--	--	--	--	Install metal inlet marker on existing CMP.
	0.280	--	--	--	--	--	--	--	--	--	--	--	--	--	--	--	Install metal inlet marker on existing CMP.
	0.333	--	--	--	--	--	--	--	--	--	--	--	--	--	--	--	Install metal inlet marker on existing CMP.

Gage Chart		
Gage	Dec. Inches	
	Steel	Alum.
10	.138	.135
12	.109	.105
14	.079	.075
16	.064	.060

1. Designed culvert lengths and locations are approximate.

*2. all culverts have 2-2/3" x 1/2"

unless otherwise noted.

**** Corrugated plastic pipe (CPP), Type S (double wall) shall be used for culvert sizes 24" and smaller. All larger culverts shall be aluminized steel. All aluminized steel culverts are to have hugger type bands and neoprene gaskets. Culverts 20' in length or smaller shall be one piece (no joints). No Culvert piece shall be shorter than 6 foot. Minimization of banding is required.

*4. Downspout or Standpipe Types

- 1) Full
- 2) Half
- 3) Flume

*** Downspouts and stand pipes (under 36" diameter) shall be CPP, Type C (single wall); unless otherwise specified.

- *5. 1) Conventional or Fabricated
2) Turner type
3) Slip joint

*6. Include special sections, structures, headwalls, footings & other data.

Culvert List

CULVERT LOCATIONS							DOWNSPOUT(d) or STANDPIPE(s) *4				AS BUILT			ROCK			REMARKS *6
DESIGNED *2														RIP RAP (GRADING)			
Road #	Sta./ M.P	SIZE	GAGE	LENGTH	CULVERT GRADE	INSTALL TYPE *3	SIZE	TYPE	LENGTH	TYPE OF ELBOW *5	SIZE	GAGE	LENGTH	INLET	OUTLET	Structure inside pipe	
4-7-13.7	5+03	18"	--	40'	--	--	--	--	--	--	--	--	--	--	--	--	Replace Culvert as marked in the field and directed by Authorized Officer. Place 20 CY 1-1/2"-0" Crushed Bedding/Backfill Rock. Spread 20 CY 6" Jaw Run Base Rock over Pipe for Surfacing, capped with 15 CY 1-1/2"-0" Crushed Rock. Install metal inlet marker.
4-7-13.9	2+82	36"	14	50'	--	--	--	--	--	--	--	--	--	20	35	--	Stream Crossing. Replace Existing Culvert as marked in field and directed by Authorized Officer (approx. 11' fill @ CL). Place 30 CY 1-1/2"-0" Crushed Bedding/Backfill Rock. Spread 25 CY 6" Jaw Run Base Rock over Pipe as Surfacing capped with 20 CY 1-1/2"-0" Crushed as marked. Place 20 CY Class 5 RipRap @ Inlet as Fill Armor. Place 35 CY Class 5 RipRap @ outlet as Fill Armor. Install metal inlet marker.
	4+09	24"	--	40'	--	--	--	--	--	--	--	--	--	10	20	--	Stream Crossing. Replace Existing Culvert as marked in field and directed by Authorized Officer (approx. 10' fill @ CL). Place 20 CY 1-1/2"-0" Crushed Bedding/Backfill Rock. Spread 20 CY 6" Jaw Run Base Rock over Pipe as Surfacing capped with 15 CY 1-1/2"-0" Crushed as marked. Place 10 CY Class 5 RipRap @ Inlet as Fill Armor. Place 20 CY Class 5 RipRap @ outlet as Fill Armor. Install metal inlet marker.
	5+88	18"	--	40'	--	--	--	--	--	--	--	--	--	--	--	--	Replace Existing Culvert as marked in field and directed by Authorized Officer (approx. 6' fill @ CL). Place 20 CY 1-1/2"-0" Crushed Bedding/Backfill Rock. Spread 20 CY 6" Jaw Run Base Rock over Pipe as Surfacing capped with 15 CY 1-1/2"-0" Crushed as marked. Install metal inlet marker.
4-7-13.11	0+55	18"	--	60'	--	--	--	--	--	--	--	--	--	--	--	--	Install Culvert in existing ditchline as marked in field and directed by Authorized Officer. Place 25 CY 1-1/2"-0" Crushed Bedding/Backfill Rock. Spread 20 CY 6" Jaw Run Base Rock over Pipe as Surfacing capped with 15 CY 1-1/2"-0" Crushed as marked.
4-7-14.3	22+06	18"	--	35'	--	--	18"	1	10'	--	--	--	--	--	--	--	Replace Culvert and downspout as marked in the field and directed by Authorized Officer. Place 15 CY 1-1/2"-0" Crushed Bedding/Backfill Rock. Spread 15 CY 6" Jaw Run Base Rock over Pipe for Surfacing, capped with 10 CY 1-1/2"-0" Crushed Rock. Install metal inlet marker.
4-7-14.4	5+24	--	--	--	--	--	--	--	--	--	--	--	--	--	--	--	Install metal inlet marker on existing CMP.
4-7-14.11	0.000	18"	--	40'	--	--	--	--	--	--	--	--	--	--	--	--	Install Culvert in existing ditchline as marked in field and directed by Authorized Officer. Place 20 CY 1-1/2"-0" Crushed Bedding/Backfill Rock. Spread 20 CY 6" Jaw Run Base Rock over Pipe as Surfacing capped with 15 CY 1-1/2"-0" Crushed as marked.
4-7-15.1/ Homestead Tie Rd.	0.010	18"	--	45'	--	--	--	--	--	--	--	--	--	--	--	--	Install Culvert as marked in field and directed by Authorized Officer. Place 20 CY 1-1/2"-0" Crushed Bedding/Backfill Rock. Spread 20 CY 6" Jaw Run Base Rock over Pipe as Surfacing capped with 15 CY 1-1/2"-0" Crushed as marked. Install metal inlet marker.
	0.102	18"	--	40'	--	--	--	--	--	--	--	--	--	--	--	--	Replace Culvert as marked in the field and directed by Authorized Officer. Place 20 CY 1-1/2"-0" Crushed Bedding/Backfill Rock. Spread 20 CY 6" Jaw Run Base Rock over Pipe for Surfacing, capped with 15 CY 1-1/2"-0" Crushed Rock. Install metal inlet marker.
	0.172	--	--	--	--	--	--	--	--	--	--	--	--	--	--	--	Install metal inlet marker on existing CMP.
	0.209	--	--	--	--	--	--	--	--	--	--	--	--	--	--	--	Install metal inlet marker on existing CMP.

Gage Chart		
Gage	Dec. Inches	
	Steel	Alum.
10	.138	.135
12	.109	.105
14	.079	.075
16	.064	.060

1. Designed culvert lengths and locations are approximate.

*2. all culverts have 2-2/3" x 1/2"

unless otherwise noted.

**** Corrugated plastic pipe (CPP), Type S (double wall) shall be used for culvert sizes 24" and smaller. All larger culverts shall be aluminized steel. All aluminized steel culverts are to have hugger type bands and neoprene gaskets. Culverts 20' in length or smaller shall be one piece (no joints). No Culvert piece shall be shorter than 6 foot. Minimization of banding is required.

*4. Downspout or Standpipe Types

- 1) Full *** Downspouts and stand pipes (under 36" diameter) shall be CPP, Type C (single wall); unless otherwise specified.
- 2) Half
- 3) Flume

- *5. 1) Conventional or Fabricated
- 2) Turner type
- 3) Slip joint

*6. Include special sections, structures, headwalls, footings & other data.

Culvert List

CULVERT LOCATIONS							DOWNSPOUT(d) or STANDPIPE(s) *4				AS BUILT			ROCK RIP RAP (GRADING)			REMARKS *6		
DESIGNED *2														(a)				(b)	
Road #	Sta./ M.P	SIZE	GAGE	LENGTH	CULVERT GRADE	INSTALL TYPE *3	SIZE	TYPE	LENGTH	TYPE OF ELBOW *5	SIZE	GAGE	LENGTH	INLET	OUTLET	Structure inside pipe			
4-7-15.1 /Homestead Tie Rd (cont.)	0.434	18"	--	35'	--	--	--	--	--	--	--	--	--	--	10	--	Replace Culvert as marked in the field and directed by Authorized Officer. Place 15 CY 1-1/2"-0" Crushed Bedding/Backfill Rock. Spread 15 CY 6" Jaw Run Base Rock over Pipe for Surfacing, capped with 10 CY 1-1/2"-0" Crushed Rock. Place 10 CY Class 5 RipRap @ outlet as fill armor. Install metal inlet marker.		
	0.565	--	--	--	--	--	--	--	--	--	--	--	--	--	--	--	Replace existing marker with metal inlet marker on existing CMP.		
	0.623	--	--	--	--	--	--	--	--	--	--	--	--	--	--	--	Install metal inlet marker on existing CPP.		
	0.663	18"	--	30'	--	--	--	--	--	--	--	--	--	--	--	--	Install Culvert as marked in the field and directed by Authorized Officer. Place 10 CY 1-1/2"-0" Crushed Bedding/Backfill Rock. Spread 10 CY 6" Jaw Run Base Rock over Pipe for Surfacing, capped with 10 CY 1-1/2"-0" Crushed Rock. Install metal inlet marker.		
	0.774	18"	--	40'	--	--	--	--	--	--	--	--	--	--	--	--	Replace Culvert as marked in the field and directed by Authorized Officer. Place 20 CY 1-1/2"-0" Crushed Bedding/Backfill Rock. Spread 20 CY 6" Jaw Run Base Rock over Pipe for Surfacing, capped with 15 CY 1-1/2"-0" Crushed Rock. Install metal inlet marker.		
	0.822	18"	--	50'	--	--	--	--	--	--	--	--	--	--	--	--	Install Culvert as marked in the field and directed by Authorized Officer (Approx. 8' fill @ CL). Place 25 CY 1-1/2"-0" Crushed Bedding/Backfill Rock. Spread 25 CY 6" Jaw Run Base Rock over Pipe for Surfacing, capped with 20 CY 1-1/2"-0" Crushed Rock. Install metal inlet marker.		
	1.013	--	--	--	--	--	--	--	--	--	--	--	--	--	--	--	Install metal inlet marker on existing CMP.		
	1.242	--	--	--	--	--	--	--	--	--	--	--	--	--	--	--	Clean buried inlet and outlet. Install metal inlet marker on existing CMP.		
	1.329	18"	--	40'	--	--	18"	1	10'	--	--	--	--	--	--	--	Replace Culvert and downspout as marked in the field and directed by Authorized Officer (Approx. 7' fill @ CL). Place 20 CY 1-1/2"-0" Crushed Bedding/Backfill Rock. Spread 20 CY 6" Jaw Run Base Rock over Pipe for Surfacing, capped with 15 CY 1-1/2"-0" Crushed Rock. Install metal inlet marker.		
	1.493	18"	--	50'	--	--	--	--	--	--	--	--	--	--	--	--	Replace Culvert as marked in the field and directed by Authorized Officer. Place 20 CY 1-1/2"-0" Crushed Bedding/Backfill Rock. Spread 20 CY 6" Jaw Run Base Rock over Pipe for Surfacing, capped with 15 CY 1-1/2"-0" Crushed Rock. Construct a lead-off ditch from culvert outlet as directed. Install metal inlet marker.		
	1.604	18"	--	40'	--	--	18"	1	10'	--	--	--	--	--	--	--	Replace Culvert and downspout as marked in the field and directed by Authorized Officer. Place 20 CY 1-1/2"-0" Crushed Bedding/Backfill Rock. Spread 20 CY 6" Jaw Run Base Rock over Pipe for Surfacing, capped with 15 CY 1-1/2"-0" Crushed Rock. Install metal inlet marker.		
	1.764	24"	--	55'	--	--	--	--	--	--	--	--	20	40	--	--	Stream Crossing. Replace Existing Culvert as marked in field and directed by Authorized Officer (approx. 12' fill @ CL). Place 20 CY 1-1/2"-0" Crushed Bedding/Backfill Rock. Spread 20 CY 6" Jaw Run Base Rock over Pipe as Surfacing capped with 15 CY 1-1/2"-0" Crushed as marked. Place 20 CY Class 5 RipRap @ Inlet as Fill Armor. Place 40 CY Class 5 RipRap @ outlet as Fill Armor. Install metal inlet marker.		
	1.898	--	--	--	--	--	--	--	--	--	--	--	--	--	--	--	Install metal inlet marker on existing CMP.		
	1.940	30"	14	50'	--	--	--	--	--	--	--	--	10	40	--	--	Stream Crossing. Replace Existing Culvert as marked in field and directed by Authorized Officer (existing: approx. 9' fill @ CL). New installation to be deeper/steeper as directed. Place 30 CY 1-1/2"-0" Crushed Bedding/Backfill Rock. Spread 25 CY 6" Jaw Run Base Rock over Pipe as Surfacing capped with 20 CY 1-1/2"-0" Crushed as marked. Place 10 CY Class 5 RipRap @ Inlet as Fill Armor. Place 40 CY Class 5 RipRap @ outlet as Stabilization Wall/Energy Dissipater. Install metal inlet marker.		
	2.036	24"	--	65'	--	--	--	--	--	--	--	--	20	90	--	--	Stream Crossing. Replace Existing Culvert as marked in field and directed by Authorized Officer (approx. 15' fill @ CL). Remove log fill. Place 25 CY 1-1/2"-0" Crushed Bedding/Backfill Rock. Spread 20 CY 6" Jaw Run Base Rock over Pipe as Surfacing capped with 15 CY 1-1/2"-0" Crushed as marked. Place 20 CY Class 5 RipRap @ Inlet as Fill Armor. Place 90 CY Class 5 RipRap @ outlet as Stabilization Wall. Existing RipRap on fill slope may be salvaged and utilized. Install metal inlet marker.		
	2.138	36"	14	40'	--	--	--	--	--	--	--	--	--	10	--	--	Stream Crossing. Replace Existing Culvert as marked in field and directed by Authorized Officer (approx. 5' fill @ CL). Place 20 CY 1-1/2"-0" Crushed Bedding/Backfill Rock. Spread 20 CY 6" Jaw Run Base Rock over Pipe as Surfacing capped with 15 CY 1-1/2"-0" Crushed as marked. Place 10 CY Class 5 RipRap @ outlet as Fill Armor. Install metal inlet marker.		
	2.219	18"	--	35'	--	--	--	--	--	--	--	--	--	--	--	--	Replace Culvert as marked in the field and directed by Authorized Officer. Place 15 CY 1-1/2"-0" Crushed Bedding/Backfill Rock. Spread 15 CY 6" Jaw Run Base Rock over Pipe for Surfacing, capped with 10 CY 1-1/2"-0" Crushed Rock. Install metal inlet marker.		
	2.357	--	--	--	--	--	--	--	--	--	--	--	--	--	--	--	Install metal inlet marker on existing CMP.		
	2.438	--	--	--	--	--	--	--	--	--	--	--	--	--	--	--	Clean buried inlet and Catch Basin. Replace metal inlet marker on existing CMP.		
	2.570	18"	--	35'	--	--	--	--	--	--	--	--	--	10	--	--	Replace Existing Culvert as marked in field and directed by Authorized Officer (Approx. 6' fill @ CL). Place 15 CY 1-1/2"-0" Crushed Bedding/Backfill Rock. Spread 15 CY 6" Jaw Run Base Rock over Pipe as Surfacing capped with 10 CY 1-1/2"-0" Crushed as marked. Spread an additional 30 CY 6" Jaw Run Base Rock on inside of road corner. Place 10 CY Class 5 RipRap @ outlet as fill armor. Install metal inlet marker.		
	2.768	--	--	--	--	--	--	--	--	--	--	--	--	--	--	--	Install metal inlet marker on existing CMP.		
	2.957	36"	14	70'	--	--	--	--	--	--	--	--	30	65	--	--	Stream Crossing. Replace Existing Culvert as marked in field and directed by Authorized Officer (approx. 17' fill @ CL). Place 40 CY 1-1/2"-0" Crushed Bedding/Backfill Rock. Spread 30 CY 6" Jaw Run Base Rock over Pipe as Surfacing capped with 20 CY 1-1/2"-0" Crushed as marked. Place 30 CY Class 5 RipRap @ Inlet as Fill Armor. Place 65 CY Class 5 RipRap @ outlet as Stabilization Wall/Energy Dissipater. Install metal inlet marker.		
	3.115	18"	--	30'	--	--	--	--	--	--	--	--	--	--	--	--	Replace Culvert as marked in the field and directed by Authorized Officer. Place 10 CY 1-1/2"-0" Crushed Bedding/Backfill Rock. Spread 10 CY 6" Jaw Run Base Rock over Pipe for Surfacing, capped with 10 CY 1-1/2"-0" Crushed Rock. Install metal inlet marker.		
4-7-15.8	0+18	18"	--	50'	--	--	--	--	--	--	--	--	--	--	--	--	Install Culvert as marked in the field and directed by Authorized Officer. Place 20 CY 1-1/2"-0" Crushed Bedding/Backfill Rock. Spread 20 CY 6" Jaw Run Base Rock over Pipe for Surfacing, capped with 15 CY 1-1/2"-0" Crushed Rock.		
4-7-15.9	0+13	18"	--	50'	--	--	--	--	--	--	--	--	--	--	--	--	Install Culvert as marked in the field and directed by Authorized Officer. Place 20 CY 1-1/2"-0" Crushed Bedding/Backfill Rock. Spread 20 CY 6" Jaw Run Base Rock over Pipe for Surfacing, capped with 15 CY 1-1/2"-0" Crushed Rock.		

Gage Chart		
Gage	Dec. Inches	
	Steel	Alum.
10	.138	.135
12	.109	.105
14	.079	.075
16	.064	.060

1. Designed culvert lengths and locations are approximate.

*2. all culverts have 2-2/3" x 1/2" unless otherwise noted.

*4. Downspout or Standpipe Types
1) Full
2) Half
3) Flume

*** Downspouts and stand pipes (under 36" diameter) shall be CPP, Type C (single wall); unless otherwise specified.

**** Corrugated plastic pipe (CPP), Type S (double wall) shall be used for culvert sizes 24" and smaller. All larger culverts shall be aluminized steel. All aluminized steel culverts are to have hugger type bands and neoprene gaskets. Culverts 20' in length or smaller shall be one piece (no joints). No Culvert piece shall be shorter than 6 foot. Minimization of banding is required.

*5. 1) Conventional or Fabricated
2) Turner type
3) Slip joint

*6. Include special sections, structures, headwalls, footings & other data.

Culvert List

CULVERT LOCATIONS							DOWNSPOUT(d) or STANDPIPE(s) *4				AS BUILT			ROCK RIP RAP (GRADING)			REMARKS *6
DESIGNED *2														(a) (b)			
Road #	Sta./ M.P	SIZE	GAGE	LENGTH	CULVERT GRADE	INSTALL TYPE *3	SIZE	TYPE	LENGTH	TYPE OF ELBOW *5	SIZE	GAGE	LENGTH	INLET	OUTLET	Structure inside pipe	
4-7-24.0/ Homestead Rd.	0.169	--	--	--	--	--	--	--	--	--	--	--	--	--	--	--	Clean buried inlet and outlet. Install metal inlet marker on existing CMP.
	0.424	--	--	--	--	--	--	--	--	--	--	--	--	--	10	--	Stream. Existing CMP Good. Place 10 CY Class 5 RipRap @ outlet as energy dissipater.
	0.453	24"	--	35'	--	--	--	--	--	--	--	--	--	--	--	--	Stream Crossing. Replace Existing Culvert as marked in field and directed by Authorized Officer (existing: approx. 5' fill @ CL). Place 15 CY 1-1/2"-0" Crushed Bedding/Backfill Rock. Spread 15 CY 6" Jaw Run Base Rock over Pipe as Surfacing capped with 10 CY 1-1/2"-0" Crushed as marked. Install metal inlet marker.
	0.558	18"	--	35'	--	--	--	--	--	--	--	--	--	--	--	--	Replace Existing Culvert as marked in field and directed by Authorized Officer. Place 15 CY 1-1/2"-0" Crushed Bedding/Backfill Rock. Spread 15 CY 6" Jaw Run Base Rock over Pipe for Surfacing capped with 10 CY 1-1/2"-0" Crushed Rock. Install metal inlet marker.
	0.609	18"	--	40'	--	--	--	--	--	--	--	--	--	--	--	--	Replace Existing Culvert as marked in field and directed by Authorized Officer (Approx. 5' fill @ CL). Place 20 CY 1-1/2"-0" Crushed Bedding/Backfill Rock. Spread 20 CY 6" Jaw Run Base Rock over Pipe for Surfacing capped with 15 CY 1-1/2"-0" Crushed Rock. Install metal inlet marker.
	0.717	18"	--	55'	--	--	--	--	--	--	--	--	--	--	40	--	Replace Existing Culvert as marked in field and directed by Authorized Officer (Approx. 12' fill @ CL). Place 25 CY 1-1/2"-0" Crushed Bedding/Backfill Rock. Spread 25 CY 6" Jaw Run Base Rock over Pipe for Surfacing capped with 20 CY 1-1/2"-0" Crushed Rock. Place 40 CY Class 5 RipRap @ outlet as fill armor. Install metal inlet marker.
	0.946	--	--	--	--	--	--	--	--	--	--	--	--	--	--	--	Install metal inlet marker on existing CMP.
	0.998	--	--	--	--	--	--	--	--	--	--	--	--	--	--	--	Install metal inlet marker on existing CMP.
	1.037	--	--	--	--	--	--	--	--	--	--	--	--	--	--	--	Install metal inlet marker on existing CMP.
	1.118	18"	--	40'	--	--	--	--	--	--	--	--	--	--	--	--	Replace Existing Culvert as marked in field and directed by Authorized Officer. Place 20 CY 1-1/2"-0" Crushed Bedding/Backfill Rock. Spread 20 CY 6" Jaw Run Base Rock over Pipe for Surfacing capped with 15 CY 1-1/2"-0" Crushed Rock. Install metal inlet marker.
	1.216	18"	--	30'	--	--	--	--	--	--	--	--	--	--	--	--	Install Culvert as marked in field and directed by Authorized Officer. Place 10 CY 1-1/2"-0" Crushed Bedding/Backfill Rock. Spread 10 CY 6" Jaw Run Base Rock over Pipe for Surfacing capped with 10 CY 1-1/2"-0" Crushed Rock. Install metal inlet marker.
	1.270	18"	--	40'	--	--	--	--	--	--	--	--	--	--	--	--	Install Culvert as marked in field and directed by Authorized Officer. Place 20 CY 1-1/2"-0" Crushed Bedding/Backfill Rock. Spread 20 CY 6" Jaw Run Base Rock over Pipe for Surfacing capped with 15 CY 1-1/2"-0" Crushed Rock. Install metal inlet marker.
	1.295	18"	--	30'	--	--	--	--	--	--	--	--	--	--	--	--	Install Culvert as marked in field and directed by Authorized Officer. Place 10 CY 1-1/2"-0" Crushed Bedding/Backfill Rock. Spread 10 CY 6" Jaw Run Base Rock over Pipe for Surfacing capped with 10 CY 1-1/2"-0" Crushed Rock. Install metal inlet marker.
4-7-24.0B	2+33	18"	--	40'	--	--	--	--	--	--	--	--	--	--	--	--	Install Culvert as marked in field and directed by Authorized Officer. Place 20 CY 1-1/2"-0" Crushed Bedding/Backfill Rock. Spread 20 CY 6" Jaw Run Base Rock over Pipe for Surfacing capped with 15 CY 1-1/2"-0" Crushed Rock. Install metal inlet marker.
	7+55	18"	--	40'	--	--	--	--	--	--	--	--	--	--	--	--	Install Culvert as marked in field and directed by Authorized Officer. Place 20 CY 1-1/2"-0" Crushed Bedding/Backfill Rock. Spread 20 CY 6" Jaw Run Base Rock over Pipe for Surfacing capped with 15 CY 1-1/2"-0" Crushed Rock. Install metal inlet marker.
	11+78	24"	--	45'	--	--	--	--	--	--	--	--	10	10	--	--	Stream Crossing. Install Culvert as marked in field and directed by Authorized Officer (approx. 5' fill @ CL). Place 20 CY 1-1/2"-0" Crushed Bedding/Backfill Rock. Spread 20 CY 6" Jaw Run Base Rock over Pipe for Surfacing, capped with 15 CY 1-1/2"-0" Crushed Rock. Place 10 CY Class 5 RipRap @ Inlet as fill armor. Place 10 CY Class 5 RipRap @ outlet as fill armor. Install metal inlet marker.
	13+20	18"	--	40'	--	--	--	--	--	--	--	--	--	--	--	--	Install Culvert as marked in field and directed by Authorized Officer. Place 20 CY 1-1/2"-0" Crushed Bedding/Backfill Rock. Spread 20 CY 6" Jaw Run Base Rock over Pipe for Surfacing capped with 15 CY 1-1/2"-0" Crushed Rock. Install metal inlet marker.
	18+90	18"	--	40'	--	--	--	--	--	--	--	--	--	--	--	--	Install Culvert as marked in field and directed by Authorized Officer. Place 20 CY 1-1/2"-0" Crushed Bedding/Backfill Rock. Spread 20 CY 6" Jaw Run Base Rock over Pipe for Surfacing capped with 15 CY 1-1/2"-0" Crushed Rock. Install metal inlet marker.
		Gage Chart		<p>1. Designed culvert lengths and locations are approximate.</p> <p>*2. all culverts have 2-2/3" x 1/2" unless otherwise noted.</p> <p>**** Corrugated plastic pipe (CPP), Type S (double wall) shall be used for culvert sizes 24" and smaller. All larger culverts shall be aluminized steel. All aluminized steel culverts are to have hugger type bands and neoprene gaskets. Culverts 20' in length or smaller shall be one piece (no joints). No Culvert piece shall be shorter than 6 foot. Minimization of banding is required.</p>													
		Dec. Inches		<p>*4. Downspout or Standpipe Types</p> <p>1) Full *** Downspouts and stand pipes (under 36" diameter) shall be CPP, Type C (single wall); unless otherwise specified.</p> <p>2) Half</p> <p>3) Flume</p>													
		Steel Alum.		<p>*5. 1) Conventional or Fabricated 2) Turner type 3) Slip joint</p> <p>*6. Include special sections, structures, headwalls, footings & other data.</p>													
		10 .138 .135															
		12 .109 .105															
		14 .079 .075															
		16 .064 .060															

Culvert List

CULVERT LOCATIONS DESIGNED *2							DOWNSPOUT(d) or STANDPIPE(s) *4				AS BUILT			ROCK RIP RAP (GRADING)			REMARKS *6	
Road #	Sta./ M.P	SIZE	GAGE	LENGTH	CULVERT GRADE	INSTALL TYPE *3	SIZE	TYPE	LENGTH	TYPE OF ELBOW *5	SIZE	GAGE	LENGTH	INLET	OUTLET	Structure inside pipe		
4-7-24.1	0.000	18"	--	60'	--	--	--	--	--	--	--	--	--	--	--	--	Install Culvert as marked in field and directed by Authorized Officer. Place 25 CY 1-1/2"-0" Crushed Bedding/Backfill Rock. Spread 25 CY 6" Jaw Run Base Rock over Pipe for Surfacing capped with 20 CY 1-1/2"-0" Crushed Rock. Construct lead-off ditch from outlet as directed.	
	0.085	24"	--	50'	--	--	--	--	--	--	--	--	--	--	10	--	Stream Crossing. Replace Existing Culvert as marked in field and directed by Authorized Officer (existing: approx. 6' fill @ CL). Place 20 CY 1-1/2"-0" Crushed Bedding/Backfill Rock. Spread 20 CY 6" Jaw Run Base Rock over Pipe as Surfacing capped with 15 CY 1-1/2"-0" Crushed as marked. Place 10 CY Class 5 RipRap @ outlet as fill armor. Install metal inlet marker.	
	0.192	18"	--	40'	--	--	--	--	--	--	--	--	--	--	--	--	Replace Culvert as marked in field and directed by Authorized Officer. Place 20 CY 1-1/2"-0" Crushed Bedding/Backfill Rock. Spread 20 CY 6" Jaw Run Base Rock over Pipe for Surfacing capped with 15 CY 1-1/2"-0" Crushed Rock. Install metal inlet marker.	
4-7-27.2	0.025	--	--	--	--	--	--	--	--	--	--	--	--	--	--	--	Stream Crossing. Install metal inlet marker on existing CMP.	
	0.110	--	--	--	--	--	--	--	--	--	--	--	--	--	--	--	Stream Crossing. Install metal inlet marker on existing CMP.	
	0.172	18"	--	40'	--	--	18"	1	10'	--	--	--	--	--	--	--	Replace Existing Culvert and downspout as marked in the field and directed by Authorized Officer. Place 20 CY 1-1/2"-0" Crushed Bedding/Backfill Rock. Spread 20 CY 6" Jaw Run Base Rock capped with lift of crushed rock over Pipe for Surfacing as marked. Install metal inlet marker.	
	0.235	24"	--	45'	--	--	--	--	--	--	--	--	--	--	10	--	Stream Crossing. Replace Existing Culvert as marked in field and directed by Authorized Officer. Place 20 CY 1-1/2"-0" Crushed Bedding/Backfill Rock. Spread 20 CY 6" Jaw Run Base Rock capped with lift of crushed rock over Pipe as Surfacing as marked. Place 10 CY Class 5 RipRap @ outlet as fill armor. Install metal inlet marker.	
	0.293	--	--	--	--	--	--	--	--	--	--	--	--	--	--	--	Existing CMP Good. Install metal inlet marker.	
	0.347	18"	--	50'	--	--	--	--	--	--	--	--	--	--	--	--	Install Culvert as marked in field and directed by Authorized Officer. Place 20 CY 1-1/2"-0" Crushed Bedding/Backfill Rock. Spread 20 CY 6" Jaw Run Base Rock capped with lift of crushed rock over Pipe for Surfacing as marked.	
	0.451	--	--	--	--	--	--	--	--	--	--	--	--	--	--	--	Install metal inlet marker on existing CMP.	
	0.511	18"	--	50'	--	--	--	--	--	--	--	--	--	--	25	--	Replace Existing Culvert as marked in field and directed by Authorized Officer (Approx. 9.5' fill @ CL). Place 20 CY 1-1/2"-0" Crushed Bedding/Backfill Rock. Spread 20 CY 6" Jaw Run Base Rock capped with lift of crushed rock over Pipe for Surfacing as marked. Place 25 CY Class 5 RipRap @ outlet as fill armor/energy dissipater. Install metal inlet marker.	
	0.744	18"	--	40'	--	--	--	--	--	--	--	--	--	--	--	--	Replace Existing Culvert as marked in the field and directed by Authorized Officer. Place 20 CY 1-1/2"-0" Crushed Bedding/Backfill Rock. Surface with the lifts of Jaw-Run capped with lift of Crushed Rock as marked. Install metal inlet marker.	
4-7-36.0/ Willamina Cr. Rd.	0.119	--	--	--	--	--	--	--	--	--	--	--	--	--	--	--	Stream Crossing. Install metal inlet marker on existing CMP.	
	0.252	--	--	--	--	--	--	--	--	--	--	--	--	5	--	--	Stream Crossing. Place 5 CY Class 5 RipRap @ inlet as fill armor. Install metal inlet marker.	
	0.372	--	--	--	--	--	--	--	--	--	--	--	--	--	--	--	Stream Crossing. Install metal inlet marker on existing CPP.	
	0.436	--	--	--	--	--	--	--	--	--	--	--	--	--	--	--	Stream Crossing. Install metal inlet marker on existing CPP.	
	0.511	--	--	--	--	--	--	--	--	--	--	--	--	--	--	--	Stream Crossing. Install metal inlet marker on existing CMP.	
	0.566	--	--	--	--	--	--	--	--	--	--	--	--	--	--	--	Stream Crossing. Install metal inlet marker on existing CPP.	
	0.630	18"	--	40'	--	--	--	--	--	--	--	--	--	--	--	--	Install Culvert as marked in the field and directed by Authorized Officer (Approx. 6.5' fill @ CL). Place 20 CY 1-1/2"-0" Crushed Bedding/Backfill Rock. Spread 20 CY 6" Jaw Run Base Rock over Pipe capped with lift of crushed rock for Surfacing Rock as marked. Install metal inlet marker.	
	0.647	--	--	--	--	--	--	--	--	--	--	--	--	--	--	--	Stream Crossing. Install metal inlet marker on existing CPP.	
	0.675	--	--	--	--	--	--	--	--	--	--	--	--	--	--	--	Install metal inlet marker on existing CPP.	
	0.695 - 0.735	--	--	--	--	--	--	--	--	--	--	--	--	--	--	--	Through-Fill/Exact Location unclear. Clean buried inlet and outlet. Install metal inlet marker on existing CMP.	
	0.806	--	--	--	--	--	--	--	--	--	--	--	--	--	--	--	Install metal inlet marker on existing CPP.	
	1.008	--	--	--	--	--	--	--	--	--	--	--	--	--	--	--	Stream Crossing. Install metal inlet marker on existing CMP.	
	1.037	--	--	--	--	--	--	--	--	--	--	--	--	--	--	--	Stream Crossing. Install metal inlet marker on existing CMP.	
	1.072	--	--	--	--	--	--	--	--	--	--	--	--	--	--	--	Stream Crossing. Install metal inlet marker on existing CMP.	
	1.085	18"	--	45'	--	--	18"	1	10'	--	--	--	--	--	--	--	Install Culvert and downspout as marked in field and directed by Authorized Officer. Place 20 CY 1-1/2"-0" Crushed Bedding/Backfill Rock. Spread 20 CY 6" Jaw Run Base Rock over Pipe as Surfacing capped with 15 CY 1-1/2"-0" Crushed as marked. Install metal inlet marker.	
		Gage Chart		<p>1. Designed culvert lengths and locations are approximate.</p> <p>*2. all culverts have 2-2/3" x 1/2" unless otherwise noted.</p> <p>*4. Downspout or Standpipe Types 1) Full 2) Half 3) Flume</p> <p>*** Downspouts and stand pipes (under 36" diameter) shall be CPP, Type C (single wall).</p> <p>*5. 1) Conventional or Fabricated 2) Turner type 3) Slip joint</p> <p>*6. Include special sections, structures, headwalls, footings & other data.</p> <p>**** Corrugated plastic pipe (CPP), Type S (double wall) shall be used for culvert sizes 24" and smaller. All larger culverts shall be aluminized steel. All aluminized steel culverts are to have hugger type bands and neoprene gaskets. Culverts 20' in length or smaller shall be one piece (no joints). No Culvert piece shall be shorter than 6 foot. Minimization of banding is required.</p>														
		Dec. Inches																
		Steel	Alum.															
		10	.138	.135														
		12	.109	.105														
		14	.079	.075														
		16	.064	.060														

Culvert List

CULVERT LOCATIONS DESIGNED *2							DOWNSPOUT(d) or STANDPIPE(s) *4				AS BUILT			ROCK RIP RAP (GRADING)			REMARKS *6				
Road #	Sta./ M.P	SIZE	GAGE	LENGTH	CULVERT GRADE	INSTALL TYPE *3	SIZE	TYPE	LENGTH	TYPE OF ELBOW *5	SIZE	GAGE	LENGTH	INLET	OUTLET	Structure inside pipe					
4-7-36.0/ Willamina Cr. Rd. (cont.)	1.141	--	--	--	--	--	--	--	--	--	--	--	--	--	60	--	Stream. Existing CMP Good. Place 60 CY Class 5 RipRap @ outlet as fill armor/stabilization wall.				
	1.247	18"	--	40'	--	--	18"	1	10'	--	--	--	--	--	--	--	Install Culvert and downspout as marked in field and directed by Authorized Officer. Place 20 CY 1-1/2"-0" Crushed Bedding/Backfill Rock. Spread 20 CY 6" Jaw Run Base Rock capped with lift of crushed rock over Pipe as Surfacing Rock as marked. Install metal inlet marker.				
	1.281	--	--	--	--	--	--	--	--	--	--	--	--	--	--	--	Stream Crossing. Install metal inlet marker on existing CMP.				
	1.303	--	--	--	--	--	--	--	--	--	--	--	--	--	--	--	Stream Crossing. Install metal inlet marker on existing CMP.				
	1.320	18"	--	50'	--	--	--	--	--	--	--	--	--	--	--	--	Install Culvert as marked in field and directed by Authorized Officer. Place 20 CY 1-1/2"-0" Crushed Bedding/Backfill Rock. Spread 20 CY 6" Jaw Run Base Rock capped with lift of crushed rock over Pipe as Surfacing Rock as marked. Install metal inlet marker.				
	1.394	--	--	--	--	--	--	--	--	--	--	--	--	--	--	--	Stream Crossing. Install metal inlet marker on existing CMP.				
	1.421	--	--	--	--	--	--	--	--	--	--	--	--	--	--	--	Stream Crossing. Install metal inlet marker on existing CMP.				
	1.452	18"	--	45'	--	--	--	--	--	--	--	--	--	--	--	--	Install Culvert as marked in field and directed by Authorized Officer (Approx. 6' fill @ CL). Place 20 CY 1-1/2"-0" Crushed Bedding/Backfill Rock. Spread 20 CY 6" Jaw Run Base Rock capped with lift of crushed rock over Pipe as marked. Install metal inlet marker.				
	1.688	--	--	--	--	--	--	--	--	--	--	--	--	--	--	--	Install metal inlet marker on existing CPP.				
	1.828	--	--	--	--	--	--	--	--	--	--	--	--	--	--	--	Clean buried inlet. Install metal inlet marker on existing CPP.				
	1.976	--	--	--	--	--	--	--	--	--	--	--	--	--	--	--	Install metal inlet marker on existing CMP.				
	2.168	18"	--	45'	--	--	18"	1	10'	--	--	--	--	--	--	--	Install Culvert and downspout as marked in field and directed by Authorized Officer (Approx. 7' fill @ CL). Place 20 CY 1-1/2"-0" Crushed Bedding/Backfill Rock. Spread 20 CY 6" Jaw Run Base Rock over Pipe for Surfacing, capped with 15 CY 1-1/2"-0" Crushed Rock. Re-use existing RipRap as fill armor after culvert installation. Install metal inlet marker.				
	2.186	36"	14	40'	--	--	--	--	--	--	--	--	--	--	10	--	Stream Crossing. Replace Existing Culvert as marked in the field and directed by Authorized Officer (Approx. 5' fill @ CL). Place 25 CY 1-1/2"-0" Crushed Bedding/Backfill Rock. Spread 20 CY 6" Jaw Run Base Rock over Pipe for Surfacing capped with 20 CY 1-1/2"-0" Crushed Rock. Place 10 CY Class 5 RipRap @ outlet as fill armor. Install metal inlet marker.				
	2.375	18"	--	45'	--	--	18"	1	20'	--	--	--	--	--	75	--	Replace Existing Culvert and downspout as marked in the field and directed by Authorized Officer (Approx. 9' fill @ CL). Place 20 CY 1-1/2"-0" Crushed Bedding/Backfill Rock. Spread 40 CY 6" Jaw Run Base Rock capped with lift of crushed rock over Pipe for Surfacing as marked. Place 75 CY Class 5 RipRap @ outlet as Stabilization Wall. Excavate road down and construct a 6' side bench to start RipRap placement to repair fill slope. Install metal inlet marker.				
	2.659	--	--	--	--	--	--	--	--	--	--	--	--	--	--	--	Seep. Install metal inlet marker on existing CPP.				
	2.798	48"	14	50'	--	--	--	--	--	--	--	--	--	10	420	--	Stream Crossing. Replace Existing Culvert as marked in the field and directed by Authorized Officer (Approx. 10' fill @ CL). Place 50 CY 1-1/2"-0" Crushed Bedding/Backfill Rock. Spread 40 CY 6" Jaw Run Base Rock over Pipe for Surfacing, capped with 30 CY 1-1/2"-0" Crushed Rock. Place 10 CY Class 5 RipRap @ inlet as fill armor. Between MP 2.786 - 2.798: Place 420 CY Class 5 RipRap @ as Stabilization Wall. Stabilization Wall will continue through culvert installation area. Culvert shall be placed on top of a portion of the Stabilization Wall, which will then act as an energy dissipater. Install metal inlet marker.				
	3.025	18"	--	45'	--	--	18"	1	10'	--	--	--	--	--	--	--	Replace Existing Culvert and downspout as marked in the field and directed by Authorized Officer. Place 20 CY 1-1/2"-0" Crushed Bedding/Backfill Rock. Spread 20 CY 6" Jaw Run Base Rock over Pipe for Surfacing capped with 15 CY of 1-1/2"-0" Crushed Rock. Install metal inlet marker.				
	3.143	18"	--	40'	--	--	18"	1	10'	--	--	--	--	--	--	--	Replace Existing Culvert and downspout as marked in the field and directed by Authorized Officer. Place 20 CY 1-1/2"-0" Crushed Bedding/Backfill Rock. Spread 20 CY 6" Jaw Run Base Rock over Pipe for Surfacing capped with 15 CY of 1-1/2"-0" Crushed Rock. Install metal inlet marker.				
	3.384	--	--	--	--	--	--	--	--	--	--	--	--	--	--	--	Install metal inlet marker on existing CPP.				
	3.417	--	--	--	--	--	--	--	--	--	--	--	--	--	--	--	Stream Crossing. Install metal inlet marker on existing CPP.				
	3.586	--	--	--	--	--	--	--	--	--	--	--	--	--	--	--	Install metal inlet marker on existing CPP.				
	3.759	--	--	--	--	--	--	--	--	--	--	--	--	--	--	--	Clean buried inlet and repair. Install metal inlet marker on existing CMP.				
	3.824	18"	--	45'	--	--	--	--	--	--	--	--	--	--	--	--	Install Culvert as marked in the field and directed by Authorized Officer. Place 20 CY 1-1/2"-0" Crushed Bedding/Backfill Rock. Spread 20 CY 6" Jaw Run Base Rock over Pipe for Surfacing capped with 15 CY of 1-1/2"-0" Crushed Rock. Ditchline ends on left after culvert. Install metal inlet marker.				
	3.846	--	--	--	--	--	--	--	--	--	--	--	--	--	--	--	Install metal inlet marker on existing CMP. Ditchline on left resumes.				
	3.966	18"	--	45'	--	--	--	--	--	--	--	--	--	--	--	--	Install Culvert as marked in the field and directed by Authorized Officer. Place 20 CY 1-1/2"-0" Crushed Bedding/Backfill Rock. Spread 20 CY 6" Jaw Run Base Rock over Pipe for Surfacing capped with 15 CY of 1-1/2"-0" Crushed Rock. Install metal inlet marker.				
	4.007	--	--	--	--	--	--	--	--	--	--	--	--	--	--	--	Install metal inlet marker on existing CMP.				
	4.078	--	--	--	--	--	--	--	--	--	--	--	--	--	--	--	Install metal inlet marker on existing CMP.				
	4.157	--	--	--	--	--	--	--	--	--	--	--	--	--	--	--	Stream Crossing Install metal inlet marker on existing CMP.				
			Dec. Inches	and locations are approximate.							*4. Downspout or Standpipe Types			2) Turner type			*6. Include special sections, structures, headwalls, footings & other data.				
			Steel	Alum.	*2. all culverts have 2-2/3" x 1/2"							1) Full			*** Downspouts and stand pipes (under 36" diameter) shall be CPP, Type C (single wall).			3) Slip joint			
			10	.138	.135	unless otherwise noted.							2) Half								
			12	.109	.105								3) Flume								
			14	.079	.075																
			16	.064	.060																
**** Corrugated plastic pipe (CPP), Type S (double wall) shall be used for culvert sizes 24" and smaller. All larger culverts shall be aluminized steel. All aluminized steel culverts are to have hugger type bands and neoprene gaskets. Culverts 20' in length or smaller shall be one piece (no joints). No Culvert piece shall be shorter than 6 foot. Minimization of banding is required.																					

Culvert List

CULVERT LOCATIONS							DOWNSPOUT(d) or STANDPIPE(s) *4				AS BUILT			ROCK			REMARKS *6
DESIGNED *2														RIP RAP (GRADING)			
Road #	Sta./ M.P	SIZE	GAGE	LENGTH	CULVERT GRADE	INSTALL TYPE *3	SIZE	TYPE	LENGTH	TYPE OF ELBOW *5	SIZE	GAGE	LENGTH	INLET	OUTLET	Structure inside pipe	
4-7-36.0/ Willamina Cr. Rd. (cont.)	4.225	--	--	--	--	--	--	--	--	--	--	--	--	--	--	--	Stream Crossing. Install metal inlet marker on existing CPP.
	4.229	--	--	--	--	--	--	--	--	--	--	--	--	--	--	--	Stream Crossing. Install metal inlet marker on existing CPP.
	4.316	--	--	--	--	--	--	--	--	--	--	--	--	--	--	--	Install metal inlet marker on existing CPP.
	4.536	18"	--	50'	--	--	--	--	--	--	--	--	--	--	--	--	Replace Existing Culvert as marked in field and directed by Authorized Officer. Place 20 CY 1-1/2"-0" Crushed Bedding/Backfill Rock. Spread 20 CY 6" Jaw Run Base Rock over Pipe as Surfacing capped with 15 CY 1-1/2"-0" Crushed as marked. Install metal inlet marker.
	4.550	--	--	--	--	--	--	--	--	--	--	--	--	--	--	--	Stream Crossing. Install metal inlet marker on existing CPP.
	4.633	--	--	--	--	--	--	--	--	--	--	--	--	--	--	--	Stream Crossing. Install metal inlet marker on existing CPP.
	4.684	--	--	--	--	--	--	--	--	--	--	--	--	--	--	--	Stream Crossing. Install metal inlet marker on existing CMP. Spread 30 CY 6" Jaw-Run Base Rock on right side of road to build up and allow appropriate width.
	4.720	18"	--	40'	--	--	--	--	--	--	--	--	--	--	--	--	Replace Existing Culvert as marked in field and directed by Authorized Officer. Place 20 CY 1-1/2"-0" Crushed Bedding/Backfill Rock. Spread 20 CY 6" Jaw Run Base Rock over Pipe as Surfacing capped 15 CY 1-1/2"-0" Crushed as marked. Install metal inlet marker.
	4.755	--	--	--	--	--	--	--	--	--	--	--	--	--	--	--	Stream Crossing. Install metal inlet marker on existing CPP.
	4.974	18"	--	40'	--	--	--	--	--	--	--	--	--	--	--	--	Install existing Culvert as marked in field and directed by Authorized Officer. Place 20 CY 1-1/2"-0" Crushed Bedding/Backfill Rock. Spread 30 CY 6" Jaw Run Base Rock over Pipe as Surfacing capped 15 CY 1-1/2"-0" Crushed as marked. Install metal inlet marker.
	5.014	18"	--	40'	--	--	--	--	--	--	--	--	--	--	--	--	Install Culvert as marked in field and directed by Authorized Officer. Place 20 CY 1-1/2"-0" Crushed Bedding/Backfill Rock. Spread 20 CY 6" Jaw Run Base Rock over Pipe as Surfacing capped 15 CY 1-1/2"-0" Crushed as marked. Install metal inlet marker.
	5.065	--	--	--	--	--	--	--	--	--	--	--	--	--	--	--	Stream Crossing. Install metal inlet marker on existing CMP.
	5.188	--	--	--	--	--	--	--	--	--	--	--	--	--	--	--	Install metal inlet marker on existing CMP.
	5.242	--	--	--	--	--	--	--	--	--	--	--	--	--	--	--	Install metal inlet marker on existing CMP.
	5.339	18"	--	40'	--	--	18"	1	10'	--	--	--	--	--	--	--	Install Culvert and downspout as marked in the field and directed by Authorized Officer. Place 20 CY 1-1/2"-0" Crushed Bedding/Backfill Rock. Spread 20 CY 6" Jaw Run Base Rock over Pipe for Surfacing capped with 15 CY 1-1/2"-0" Crushed Rock. Install metal inlet marker.
	5.373	18"	--	35'	--	--	18"	1	10'	--	--	--	--	--	--	--	Install Culvert and downspout as marked in the field and directed by Authorized Officer. Place 15 CY 1-1/2"-0" Crushed Bedding/Backfill Rock. Spread 15 CY 6" Jaw Run Base Rock over Pipe for Surfacing capped with 10 CY 1-1/2"-0" Crushed Rock. Install metal inlet marker.
	5.402	24"	--	40'	--	--	24"	1	10'	--	--	--	10	20	--	--	Stream Crossing. Replace Existing Culvert and downspout as marked in the field and directed by Authorized Officer. Place 20 CY 1-1/2"-0" Crushed Bedding/Backfill Rock. Spread 20 CY 6" Jaw Run Base Rock over Pipe for Surfacing, capped with 15 CY 1-1/2"-0" Crushed Rock. Place 10 CY Class 5 RipRap @ inlet as fill armor. Place 20 CY Class 5 RipRap @ outlet as fill armor. One culvert was removed, but another existing CMP was left. It needs to be removed and new culvert installation will be deeper (at stream level). Install metal inlet marker.
	5.448	18"	--	40'	--	--	18"	1	10'	--	--	--	--	--	--	--	Install Culvert and downspout as marked in the field and directed by Authorized Officer. Place 20 CY 1-1/2"-0" Crushed Bedding/Backfill Rock. Spread 20 CY 6" Jaw Run Base Rock over Pipe for Surfacing capped with 15 CY 1-1/2"-0" Crushed Rock. Install metal inlet marker.
	5.484	18"	--	35'	--	--	18"	1	10'	--	--	--	--	--	--	--	Install Culvert and downspout as marked in the field and directed by Authorized Officer. Place 15 CY 1-1/2"-0" Crushed Bedding/Backfill Rock. Spread 15 CY 6" Jaw Run Base Rock over Pipe for Surfacing capped with 10 CY of 1-1/2"-0" Crushed Rock. Install metal inlet marker.
							and locations are approximate.				*4. Downspout or Standpipe Types			2) Turner type 3) Slip joint			*6. Include special sections, structures, headwalls, footings & other data.
							*2. all culverts have 2-2/3" x 1/2"				1) Full 2) Half 3) Flume			*** Downspouts and stand pipes (under 36" diameter) shall be CPP, Type C (single wall).			
							unless otherwise noted.										
							**** Corrugated plastic pipe (CPP), Type S (double wall) shall be used for culvert sizes 24" and smaller. All larger culverts shall be aluminized steel. All aluminized steel culverts are to have hugger type bands and neoprene gaskets. Culverts 20' in length or smaller shall be one piece (no joints). No Culvert piece shall be shorter than 6 foot. Minimization of banding is required.										

Culvert List

CULVERT LOCATIONS							DOWNSPOUT(d) or STANDPIPE(s) *4				AS BUILT			ROCK			REMARKS *6			
DESIGNED *2														RIP RAP (GRADING)						
Road #	Sta./ M.P	SIZE	GAGE	LENGTH	CULVERT GRADE	INSTALL TYPE *3	SIZE	TYPE	LENGTH	TYPE OF ELBOW *5	SIZE	GAGE	LENGTH	INLET	OUTLET	Structure inside pipe				
5-7-15.0	0.000	18"	--	65'	--	--	--	--	--	--	--	--	--	--	--	--	Remove both existing culverts across the 5-7-15.0 & 5-7-22.0. Spread 40 CY 6" Jaw-Run Base Rock over culvert removals (20 CY over each removal). Replace Existing Culverts as marked in field and directed by Authorized Officer. Place 30 CY 1-1/2"-0" Crushed Bedding/Backfill Rock. Spread 30 CY 6" Jaw Run Base Rock over Pipe as Surfacing capped with 25 CY 1-1/2"-0" Crushed as marked.			
	0.043	18"	--	35'	--	--	--	--	--	--	--	--	--	--	--	--	Replace Existing Culvert as marked in field and directed by Authorized Officer. Place 15 CY 1-1/2"-0" Crushed Bedding/Backfill Rock. Spread 15 CY 6" Jaw Run Base Rock over Pipe as Surfacing capped with 10 CY 1-1/2"-0" Crushed as marked. Install metal inlet marker.			
	0.211	18"	--	30'	--	--	--	--	--	--	--	--	--	--	--	--	Replace Existing Culvert as marked in field and directed by Authorized Officer. Place 10 CY 1-1/2"-0" Crushed Bedding/Backfill Rock. Spread 10 CY 6" Jaw Run Base Rock over Pipe as Surfacing capped with 10 CY 1-1/2"-0" Crushed as marked. Install metal inlet marker.			
	0.259	18"	--	30'	--	--	--	--	--	--	--	--	--	--	--	--	Replace Existing Culvert as marked in field and directed by Authorized Officer. Place 10 CY 1-1/2"-0" Crushed Bedding/Backfill Rock. Spread 10 CY 6" Jaw Run Base Rock over Pipe as Surfacing capped with 10 CY 1-1/2"-0" Crushed as marked. Install metal inlet marker.			
	0.317	18"	--	35'	--	--	--	--	--	--	--	--	--	--	--	--	Replace Existing Culvert as marked in field and directed by Authorized Officer. Place 15 CY 1-1/2"-0" Crushed Bedding/Backfill Rock. Spread 15 CY 6" Jaw Run Base Rock over Pipe as Surfacing capped with 10 CY 1-1/2"-0" Crushed as marked. Install metal inlet marker.			
	0.541	18"	--	30'	--	--	--	--	--	--	--	--	--	--	--	--	Replace Existing Culvert as marked in field and directed by Authorized Officer. Place 10 CY 1-1/2"-0" Crushed Bedding/Backfill Rock. Spread 10 CY 6" Jaw Run Base Rock over Pipe as Surfacing capped with 10 CY 1-1/2"-0" Crushed as marked. Install metal inlet marker.			
	0.648	18"	--	30'	--	--	--	--	--	--	--	--	--	--	--	--	Replace Existing Culvert as marked in field and directed by Authorized Officer. Place 10 CY 1-1/2"-0" Crushed Bedding/Backfill Rock. Spread 10 CY 6" Jaw Run Base Rock over Pipe as Surfacing capped with 10 CY 1-1/2"-0" Crushed as marked. Install metal inlet marker.			
	0.693	18"	--	30'	--	--	--	--	--	--	--	--	--	--	--	--	Replace Existing Culvert as marked in field and directed by Authorized Officer. Place 10 CY 1-1/2"-0" Crushed Bedding/Backfill Rock. Spread 10 CY 6" Jaw Run Base Rock over Pipe as Surfacing capped 10 CY 1-1/2"-0" Crushed as marked. Install metal inlet marker.			
	0.724	18"	--	30'	--	--	--	--	--	--	--	--	--	--	--	--	Replace Existing Culvert as marked in field and directed by Authorized Officer. Place 10 CY 1-1/2"-0" Crushed Bedding/Backfill Rock. Spread 10 CY 6" Jaw Run Base Rock over Pipe as Surfacing capped 10 CY 1-1/2"-0" Crushed as marked. Install metal inlet marker.			
	0.816	18"	--	30'	--	--	--	--	--	--	--	--	--	--	--	--	Replace Existing Culvert as marked in field and directed by Authorized Officer. Place 10 CY 1-1/2"-0" Crushed Bedding/Backfill Rock. Spread 10 CY 6" Jaw Run Base Rock over Pipe as Surfacing capped 10 CY 1-1/2"-0" Crushed as marked. Install metal inlet marker.			
	0.860	24"	--	45'	--	--	--	--	--	--	--	--	--	20	--	--	Stream Crossing. Replace Existing Culvert as marked in the field and directed by Authorized Officer (Approx. 6' fill @ CL). Place 20 CY 1-1/2"-0" Crushed Bedding/Backfill Rock. Spread 20 CY 6" Jaw Run Base Rock over Pipe for Surfacing capped with 15 CY 1-1/2"-0" Crushed Rock. Place 20 CY Class 5 RipRap @ outlet as fill armor. Install metal inlet marker.			
	0.924	18"	--	35'	--	--	--	--	--	--	--	--	--	--	--	--	Replace Existing Culvert as marked in field and directed by Authorized Officer. Place 15 CY 1-1/2"-0" Crushed Bedding/Backfill Rock. Spread 15 CY 6" Jaw Run Base Rock over Pipe as Surfacing capped with 10 CY 1-1/2"-0" Crushed as marked. Install metal inlet marker.			
	0.981	18"	--	35'	--	--	--	--	--	--	--	--	--	--	--	--	Replace Existing Culvert as marked in field and directed by Authorized Officer. Place 15 CY 1-1/2"-0" Crushed Bedding/Backfill Rock. Spread 15 CY 6" Jaw Run Base Rock over Pipe as Surfacing capped with 10 CY 1-1/2"-0" Crushed as marked. Install metal inlet marker.			
	1.044	24"	--	40'	--	--	--	--	--	--	--	--	--	--	--	--	Stream Crossing. Replace Existing Culvert as marked in the field and directed by Authorized Officer (Approx. 4.5' fill @ CL). Place 20 CY 1-1/2"-0" Crushed Bedding/Backfill Rock. Spread 20 CY 6" Jaw Run Base Rock over Pipe for Surfacing, capped with 15 CY 1-1/2"-0" Crushed Rock. Install metal inlet marker.			
	1.108	18"	--	30'	--	--	--	--	--	--	--	--	--	--	--	--	Install Culvert as marked in field and directed by Authorized Officer. Place 10 CY 1-1/2"-0" Crushed Bedding/Backfill Rock. Spread 10 CY 6" Jaw Run Base Rock over Pipe as Surfacing capped 10 CY 1-1/2"-0" Crushed as marked. Install metal inlet marker.			
	1.336	18"	--	35'	--	--	--	--	--	--	--	--	--	--	--	--	Install Culvert and downspout as marked in the field and directed by Authorized Officer. Place 15 CY 1-1/2"-0" Crushed Bedding/Backfill Rock. Spread 15 CY 6" Jaw Run Base Rock over Pipe for Surfacing capped with 10 CY 1-1/2"-0" Crushed Rock. Install metal inlet marker.			
		Dec. Inches		and locations are approximate.							*4. Downspout or Standpipe Types			2) Turner type			*6. Include special sections, structures, headwalls, footings & other data.			
Gage		Steel	Alum.	*2. all culverts have 2-2/3" x 1/2" unless otherwise noted.							1) Full			*** Downspouts and stand pipes (under 36" diameter) shall be CPP, Type C (single wall).				3) Slip joint		
10		.138	.135								3) Flume									
12		.109	.105																	
14		.079	.075																	
16		.064	.060																	
**** Corrugated plastic pipe (CPP), Type S (double wall) shall be used for culvert sizes 24" and smaller. All larger culverts shall be aluminized steel. All aluminized steel culverts are to have hugger type bands and neoprene gaskets. Culverts 20' in length or smaller shall be one piece (no joints). No Culvert piece shall be shorter than 6 foot. Minimization of banding is required.																				

Culvert List

CULVERT LOCATIONS							DOWNSPOUT(d) or STANDPIPE(s) *4				AS BUILT			ROCK			REMARKS *6	
DESIGNED *2														RIP RAP (GRADING)				
Road #	Sta./ M.P	SIZE	GAGE	LENGTH	CULVERT GRADE	INSTALL TYPE *3	SIZE	TYPE	LENGTH	TYPE OF ELBOW *5	SIZE	GAGE	LENGTH	INLET	OUTLET	Structure inside pipe		
5-7-22.0/Indian Creek Rd	0.142	18"	--	40'	--	--	--	--	--	--	--	--	--	--	--	--	Replace Existing Culvert as marked in field and directed by Authorized Officer. Place 20 CY 1-1/2"-0" Crushed Bedding/Backfill Rock. Spread 20 CY 6" Jaw Run Base Rock over Pipe as Surfacing capped with 15 CY 1-1/2"-0" Crushed as marked. Install metal inlet marker.	
	0.264	--	--	--	--	--	--	--	--	--	--	--	--	--	--	--	Stream Crossing. Install metal inlet marker on existing CMP. Spread 30 CY 6" Jaw-Run Base Rock over newly widened subgrade.	
	0.467	--	--	--	--	--	--	--	--	--	--	--	--	--	--	--	Install metal inlet marker on existing CMP.	
	0.548	18"	--	30'	--	--	--	--	--	--	--	--	--	--	--	--	Replace Existing Culvert as marked in field and directed by Authorized Officer. Place 10 CY 1-1/2"-0" Crushed Bedding/Backfill Rock. Spread 10 CY 6" Jaw Run Base Rock over Pipe as Surfacing capped with 10 CY 1-1/2"-0" Crushed as marked. Install metal inlet marker.	
	0.630	18"	--	40'	--	--	--	--	--	--	--	--	--	--	--	--	Replace Existing Culvert as marked in field and directed by Authorized Officer (Approx. 7' fill @ CL). Place 20 CY 1-1/2"-0" Crushed Bedding/Backfill Rock. Spread 20 CY 6" Jaw Run Base Rock over Pipe as Surfacing capped with 15 CY 1-1/2"-0" Crushed as marked. Install metal inlet marker.	
	0.794	18"	--	40'	--	--	--	--	--	--	--	--	--	--	--	--	Replace Existing Culvert as marked in field and directed by Authorized Officer (Approx. 4' fill @ CL). Place 20 CY 1-1/2"-0" Crushed Bedding/Backfill Rock. Spread 20 CY 6" Jaw Run Base Rock over Pipe as Surfacing capped with 15 CY 1-1/2"-0" Crushed as marked. Install metal inlet marker.	
	0.864	18"	--	30'	--	--	--	--	--	--	--	--	--	--	--	--	Replace Existing Culvert as marked in field and directed by Authorized Officer. Place 10 CY 1-1/2"-0" Crushed Bedding/Backfill Rock. Spread 10 CY 6" Jaw Run Base Rock over Pipe as Surfacing capped with 10 CY 1-1/2"-0" Crushed as marked. Install metal inlet marker.	
	1.048	18"	--	35'	--	--	--	--	--	--	--	--	--	--	--	--	Replace Existing Culvert as marked in field and directed by Authorized Officer. Place 15 CY 1-1/2"-0" Crushed Bedding/Backfill Rock. Spread 15 CY 6" Jaw Run Base Rock over Pipe as Surfacing capped with 10 CY 1-1/2"-0" Crushed as marked. Install metal inlet marker.	
	1.111	18"	--	40'	--	--	--	--	--	--	--	--	--	--	--	--	Install Culvert as marked in field and directed by Authorized Officer. Place 20 CY 1-1/2"-0" Crushed Bedding/Backfill Rock. Spread 20 CY 6" Jaw Run Base Rock over Pipe as Surfacing capped 15 CY 1-1/2"-0" Crushed as marked.	
	1.137	36"	14	40'	--	--	--	--	--	--	--	--	--	--	--	--	Stream Crossing. Replace Existing Culvert as marked in the field and directed by Authorized Officer (Approx. 5' fill @ CL). Place 20 CY 1-1/2"-0" Crushed Bedding/Backfill Rock. Spread 20 CY 6" Jaw Run Base Rock over Pipe for Surfacing capped with 15 CY 1-1/2"-0" Crushed Rock. Install metal inlet marker.	
	1.259	18"	--	30'	--	--	--	--	--	--	--	--	--	--	--	--	Replace Existing Culvert as marked in field and directed by Authorized Officer. Place 10 CY 1-1/2"-0" Crushed Bedding/Backfill Rock. Spread 10 CY 6" Jaw Run Base Rock over Pipe as Surfacing capped 10 CY 1-1/2"-0" Crushed as marked. Install metal inlet marker.	
	1.305	36"	14	60'	--	--	--	--	--	--	--	--	--	10	--	--	Stream Crossing. Replace Existing Culvert as marked in the field and directed by Authorized Officer (Approx. 9' fill @ CL). Place 20 CY 1-1/2"-0" Crushed Bedding/Backfill Rock. Spread 20 CY 6" Jaw Run Base Rock over Pipe for Surfacing capped with 15 CY 1-1/2"-0" Crushed Rock. Place 10 CY @ Outlet as Energy Dissipater. Install metal inlet marker.	
	1.402	--	--	--	--	--	--	--	--	--	--	--	--	--	--	--	Install metal inlet marker on existing CMP.	
	1.497	30"	14	40'	--	--	--	--	--	--	--	--	--	10	--	--	Stream Crossing. Replace Existing Culvert as marked in the field and directed by Authorized Officer (Approx. 8' fill @ CL). Place 20 CY 1-1/2"-0" Crushed Bedding/Backfill Rock. Spread 20 CY 6" Jaw Run Base Rock over Pipe for Surfacing capped with 15 CY 1-1/2"-0" Crushed Rock. Place 10 CY @ Outlet as Fill Armor. Install metal inlet marker.	
	1.511	24"	--	35'	--	--	--	--	--	--	--	--	--	--	--	--	Stream Crossing. Install Culvert as marked in the field and directed by Authorized Officer. Place 15 CY 1-1/2"-0" Crushed Bedding/Backfill Rock. Spread 15 CY 6" Jaw Run Base Rock over Pipe for Surfacing, capped with 10 CY 1-1/2"-0" Crushed Rock. Install metal inlet marker.	
	1.582	18"	--	40'	--	--	--	--	--	--	--	--	--	--	--	--	Replace Existing Culvert as marked in field and directed by Authorized Officer. Place 20 CY 1-1/2"-0" Crushed Bedding/Backfill Rock. Spread 20 CY 6" Jaw Run Base Rock over Pipe as Surfacing capped 15 CY 1-1/2"-0" Crushed as marked. Install metal inlet marker.	
	1.746	18"	--	30'	--	--	--	--	--	--	--	--	--	--	--	--	Replace Existing Culvert as marked in field and directed by Authorized Officer. Place 10 CY 1-1/2"-0" Crushed Bedding/Backfill Rock. Spread 10 CY 6" Jaw Run Base Rock over Pipe as Surfacing capped with 10 CY 1-1/2"-0" Crushed as marked. Install metal inlet marker.	
	1.804	36"	14	50'	--	--	--	--	--	--	--	--	--	40	--	--	Stream Crossing. Replace Existing Culvert as marked in the field and directed by Authorized Officer (Approx. 8.5' fill @ CL). Place 30 CY 1-1/2"-0" Crushed Bedding/Backfill Rock. Spread 25 CY 6" Jaw Run Base Rock over Pipe for Surfacing, capped with 20 CY 1-1/2"-0" Crushed Rock. Place 40 CY Class 5 RipRap @ Outlet as Fill Armor. Install metal inlet marker.	
	1.869	18"	--	30'	--	--	--	--	--	--	--	--	--	--	--	--	Replace Existing Culvert as marked in field and directed by Authorized Officer. Place 10 CY 1-1/2"-0" Crushed Bedding/Backfill Rock. Spread 10 CY 6" Jaw Run Base Rock over Pipe as Surfacing capped with 10 CY 1-1/2"-0" Crushed as marked. Install metal inlet marker.	
	1.964	18"	--	30'	--	--	--	--	--	--	--	--	--	--	--	--	Replace Existing Culvert as marked in field and directed by Authorized Officer. Place 10 CY 1-1/2"-0" Crushed Bedding/Backfill Rock. Spread 10 CY 6" Jaw Run Base Rock over Pipe as Surfacing capped with 10 CY 1-1/2"-0" Crushed as marked. Install metal inlet marker.	
	2.131	18"	--	30'	--	--	--	--	--	--	--	--	--	--	--	--	Replace Existing Culvert as marked in field and directed by Authorized Officer. Place 10 CY 1-1/2"-0" Crushed Bedding/Backfill Rock. Spread 10 CY 6" Jaw Run Base Rock over Pipe as Surfacing capped with 10 CY 1-1/2"-0" Crushed as marked. Install metal inlet marker.	
		Dec. Inches		and locations are approximate.							*4. Downspout or Standpipe Types			2) Turner type			*6. Include special sections, structures, headwalls, footings & other data.	
		Gage	Steel	Alum.	*2. all culverts have 2-2/3" x 1/2"							1) Full			*** Downspouts and stand pipes (under 36" diameter) shall be CPP, Type C (single wall).			
		10	.138	.135	unless otherwise noted.							2) Half			3) Slip joint			
		12	.109	.105								3) Flume						
		14	.079	.075														
		16	.064	.060														
		**** Corrugated plastic pipe (CPP), Type S (double wall) shall be used for culvert sizes 24" and smaller. All larger culverts shall be aluminized steel. All aluminized steel culverts are to have hugger type bands and neoprene gaskets. Culverts 20' in length or smaller shall be one piece (no joints). No Culvert piece shall be shorter than 6 foot. Minimization of banding is required.																

Culvert List

CULVERT LOCATIONS							DOWNSPOUT(d) or STANDPIPE(s) *4				AS BUILT			ROCK			REMARKS *6	
DESIGNED *2														RIP RAP (GRADING)				
Road #	Sta./ M.P	SIZE	GAGE	LENGTH	CULVERT GRADE	INSTALL TYPE *3	SIZE	TYPE	LENGTH	TYPE OF ELBOW *5	SIZE	GAGE	LENGTH	INLET	OUTLET	Structure inside pipe		
5-7-22.0 /Indian Creek Rd (cont.)	2.255	18"	--	30'	--	--	--	--	--	--	--	--	--	--	--	--	Replace Existing Culvert as marked in field and directed by Authorized Officer. Place 10 CY 1-1/2"-0" Crushed Bedding/Backfill Rock. Spread 10 CY 6" Jaw Run Base Rock over Pipe as Surfacing capped with 10 CY 1-1/2"-0" Crushed as marked. Install metal inlet marker.	
	2.852	18"	--	30'	--	--	--	--	--	--	--	--	--	--	--	--	Replace Existing Culvert as marked in field and directed by Authorized Officer. Place 10 CY 1-1/2"-0" Crushed Bedding/Backfill Rock. Spread 10 CY 6" Jaw Run Base Rock over Pipe as Surfacing capped with 10 CY 1-1/2"-0" Crushed as marked. Install metal inlet marker.	
	2.991	18"	--	30'	--	--	--	--	--	--	--	--	--	--	--	--	Replace Existing Culvert as marked in field and directed by Authorized Officer. Place 10 CY 1-1/2"-0" Crushed Bedding/Backfill Rock. Spread 10 CY 6" Jaw Run Base Rock over Pipe as Surfacing capped with 10 CY 1-1/2"-0" Crushed as marked. Install metal inlet marker.	
	3.084	18"	--	35'	--	--	--	--	--	--	--	--	--	--	--	--	Replace Existing Culvert as marked in field and directed by Authorized Officer. Place 15 CY 1-1/2"-0" Crushed Bedding/Backfill Rock. Spread 15 CY 6" Jaw Run Base Rock over Pipe as Surfacing capped with 10 CY 1-1/2"-0" Crushed as marked. Install metal inlet marker.	
	3.157	18"	--	40'	--	--	--	--	--	--	--	--	--	--	--	--	Replace Existing Culvert as marked in field and directed by Authorized Officer. Place 20 CY 1-1/2"-0" Crushed Bedding/Backfill Rock. Spread 20 CY 6" Jaw Run Base Rock over Pipe as Surfacing capped with 15 CY 1-1/2"-0" Crushed as marked. Install metal inlet marker.	
	3.217	18"	--	30'	--	--	--	--	--	--	--	--	--	--	--	--	Replace Existing Culvert as marked in field and directed by Authorized Officer. Place 10 CY 1-1/2"-0" Crushed Bedding/Backfill Rock. Spread 10 CY 6" Jaw Run Base Rock over Pipe as Surfacing capped with 10 CY 1-1/2"-0" Crushed as marked. Install metal inlet marker.	
	3.291	18"	--	40'	--	--	--	--	--	--	--	--	--	--	--	--	Replace Existing Culvert as marked in field and directed by Authorized Officer. Place 20 CY 1-1/2"-0" Crushed Bedding/Backfill Rock. Spread 20 CY 6" Jaw Run Base Rock over Pipe as Surfacing capped with 15 CY 1-1/2"-0" Crushed as marked. Install metal inlet marker.	
	3.413	18"	--	30'	--	--	--	--	--	--	--	--	--	--	--	--	Replace Existing Culvert as marked in field and directed by Authorized Officer. Place 10 CY 1-1/2"-0" Crushed Bedding/Backfill Rock. Spread 10 CY 6" Jaw Run Base Rock over Pipe as Surfacing capped with 10 CY 1-1/2"-0" Crushed as marked. Install metal inlet marker.	
							and locations are approximate.				*4. Downspout or Standpipe Types			2) Turner type			*6. Include special sections, structures, headwalls, footings & other data.	
							*2. all culverts have 2-2/3" x 1/2"				1) Full			*** Downspouts and stand pipes (under 36" diameter) shall be CPP, Type C (single wall).				3) Slip joint
							unless otherwise noted.				2) Half							
											3) Flume							
							**** Corrugated plastic pipe (CPP), Type S (double wall) shall be used for culvert sizes 24" and smaller. All larger culverts shall be aluminized steel. All aluminized steel culverts are to have hugger type bands and neoprene gaskets. Culverts 20' in length or smaller shall be one piece (no joints). No Culvert piece shall be shorter than 6 foot. Minimization of banding is required.											

U.S. DEPT. OF THE INTERIOR
 Bureau of Land Management
 NORTHWEST OREGON DISTRICT OFFICE - OREGON
CULVERT BAND DETAILS

NOTE:
 DESIGN VARIATIONS IN FASTENERS,
 (STRAPS, BARS & WELDS) WHICH
 PROVIDE A TENSILE STRENGTH OF
 7500 LBS. ARE PERMISSIBLE.

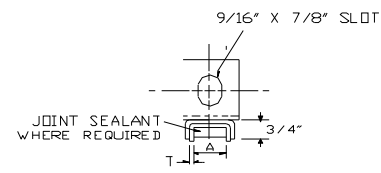
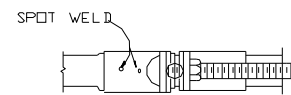
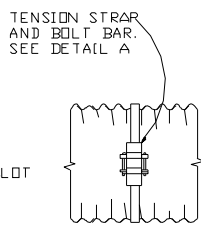
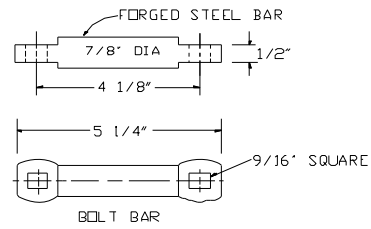
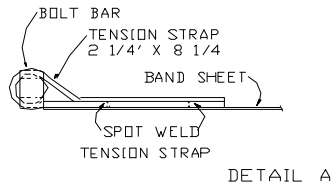

DIMENSIONS IN INCHES

T	A	PIPE WALL THICKNESS
.179	3/4	.109 OR LIGHTER
.109	1	.138 OR HEAVIER

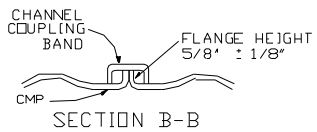
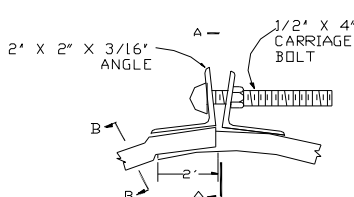

CHANNEL
 BAND
 COUPLER

NOTE:
 AS AN ALTERNATE TO SWEDGE, AN
 OVERSIZE BRIDGE CLIP MAY BE USED.

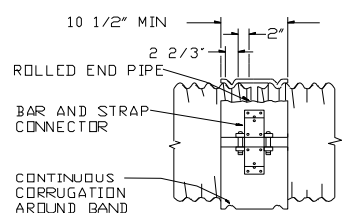

THE HUGGER COUPLER BAND OR AN APPROVED EQUIVALENT COUPLER BAND SHALL BE MADE OF THE SAME MATERIAL AND FINISH AS THE PIPES JOINED. THE COUPLER BANDS SHALL HAVE A MINIMUM WIDTH OF 10 1/2 INCHES AND MAY BE TWO NUMERICAL THICKNESSES LIGHTER THAN THE GAGE OR THICKNESS DESIGNATED FOR THE CONDUIT JOINED. THE BAND SHALL BE DESIGNED TO BE DRAWN TOGETHER WITH TWO 1/2 INCH BOLTS THROUGH USE OF A BAR AND STRAP SUITABLY WELDED TO THE BAND. THE BAND SHALL ENGAGE AND MESH WITH THE SECOND ANNULAR CORRUGATION INWARD FROM THE END OF EACH OF THE CONDUIT SECTIONS JOINED.

STANDARD CONSTRUCTION IS 1 PIECE 12' THRU 48" AND 2 PIECE 54" AND ABOVE

GASKETS AND "HUGGER" TYPE BANDS, OR AN APPROVED EQUIVALENT COUPLER, SHALL BE INSTALLED INSTALLED ON ALL 48" AND LARGER METAL PIPES.

"HUGGER" COUPLER BANDS

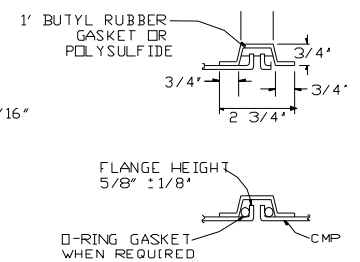
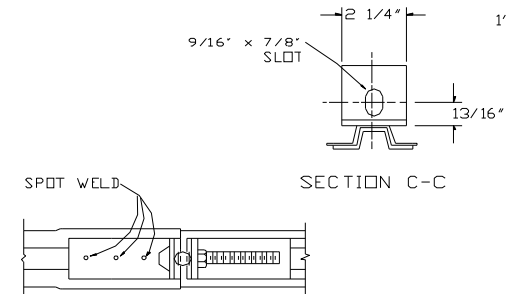

SECTION D-D
 SHOWN WITH ALTERNATE TYPES
 OF JOINT SEALERS

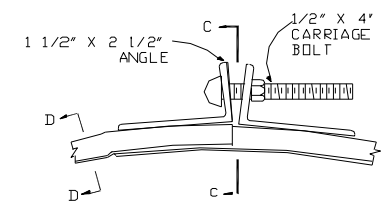

FLANGED END COUPLER

CULVERT SIZE INCHES	STANDARD COUPLER BANDS CORRUGATED							
	STD. ANNULAR		HELICAL		3' x 1'		6' x 1'	
	WIDTH	NO. OF BOLTS	WIDTH	NO. OF BOLTS	WIDTH	NO. OF BOLTS	WIDTH	NO. OF BOLTS
UNDER 18	7	2	7	2				
18 TO 54	12	3	12	3	14	3	18	3
OVER 54	24	5	24	5	24	5	24	4

DATA IN THIS BLOCK DOES NOT APPLY TO PERFORATED PIPE UNDERDRAIN. FOR BANDS WITH "PUNCH-OUT" TYPE CONNECTIONS, 2 BOLTS ARE PERMISSIBLE FOR EACH LAP. BANDS SHALL LAP 1/2 WIDTH ONTO EACH SECTION OF PIPE AND MUST FULLY ENCLOSE THE JOINT FORMING A NEARLY WATERTIGHT CONNECTION.

- Ⓐ BANDS WITH ANGLES
- Ⓑ BANDS WITH TENSION TYPE CONNECTIONS

U.S. DEPT. OF THE INTERIOR
 Bureau of Land Management
 NORTHWEST OREGON DISTRICT OFFICE - OREGON
CULVERT INSTALLATION DETAILS

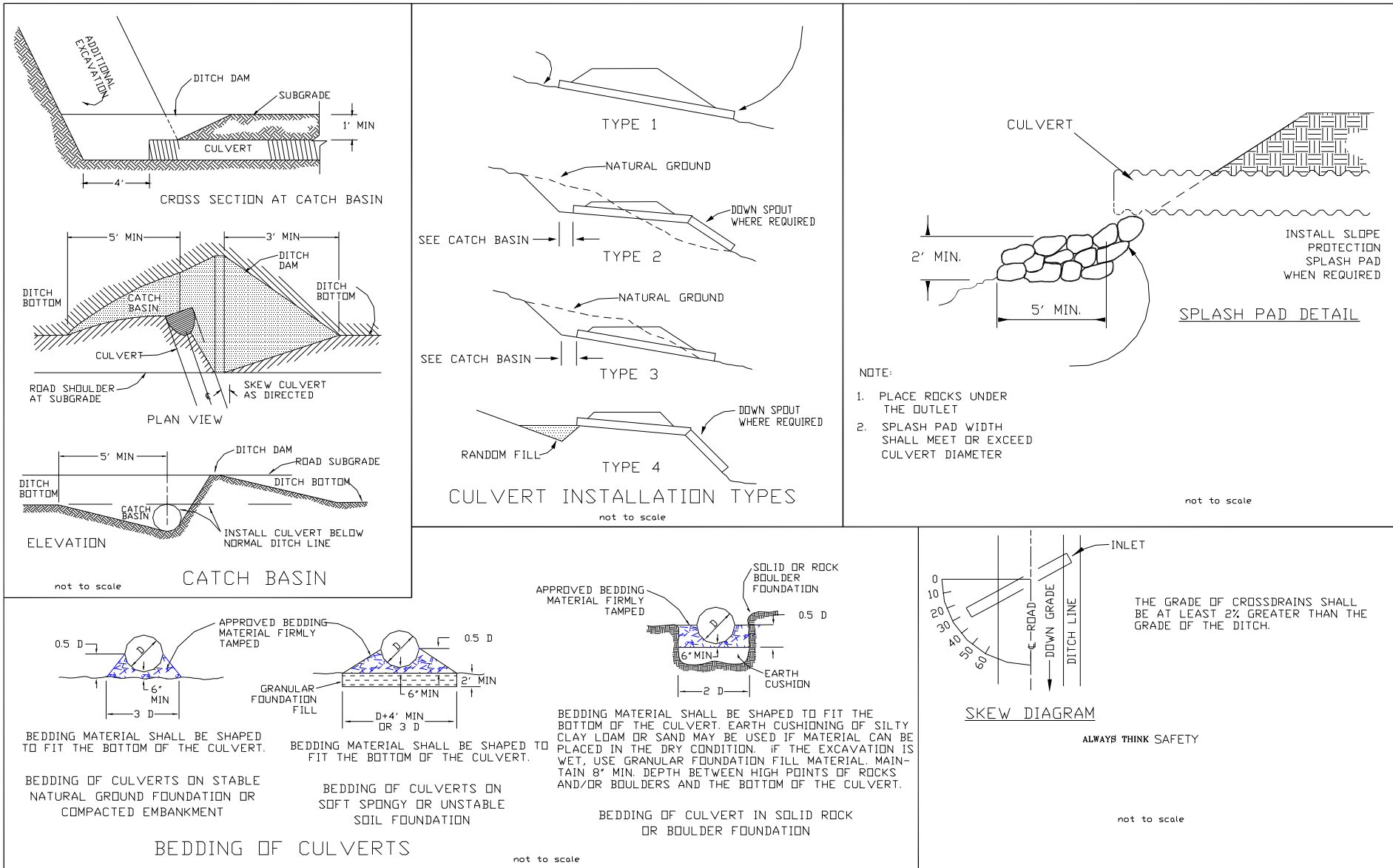

ROCK VOLUMES TOTALS

ROAD SEGMENT: 4-6-7.4			STATION: 0+00 - 41+62				
Application	Rock Size and Type	Location	Compacted Depth	Volume per Station/Item (CY)	Approx. Total (CY)	Curve Widening (CY)	Summary Totals
Road Rock	1-1/2"-0"	Cap Spot Rock	--	--	--	--	10
Road Rock	6" Jaw Run	Base Spot Rock	--	--	--	--	20
Culverts	1-1/2"-0"	Cap Spot Rock	--	--	--	--	125
Culverts	6" Jaw Run	Base Spot Rock	---	---	---	---	165
Culverts	1-1/2"-0"	Bedding/Backfill	---	---	---	---	165

ROAD SEGMENT: 4-6-18.1			STATION: 0+00 - 9+28				
Application	Rock Size and Type	Location	Compacted Depth	Volume per Station/Item (CY)	Approx. Total (CY)	Curve Widening (CY)	Summary Totals
Road Rock	1-1/2"-0"	Cap Spot Rock	--	--	--	--	10
Road Rock	6" Jaw Run	Base Spot Rock	---	---	---	---	20

ROAD SEGMENT: 4-7-1.2			STATION: 0+00 - 48+65				
Application	Rock Size and Type	Location	Compacted Depth	Volume per Station/Item (CY)	Approx. Total (CY)	Curve Widening (CY)	Summary Totals
Road Rock	1-1/2"-0"	Cap Spot Rock	--	--	--	--	30
Road Rock	3"-0"	Cap Rock: 0+00 - 48+65	8"	40	1,928	233	2,161
Road Rock	6" Jaw Run	Base Spot Rock	---	---	---	---	240
Culverts	1-1/2"-0"	Cap Spot Rock	--	--	--	--	70
Culverts	1-1/2"-0"	Bedding/Backfill	---	---	---	---	100
Energy Dissipater Outlet	RipRap: Class 5	Sta. 4+61	---	---	---	---	5

ROAD SEGMENT: 4-7-1.4 (Eastline Quarry Rd)			MILEAGE: 0.000 - 0.672				
Application	Rock Size and Type	Location	Compacted Depth	Volume per Station/Item	Approx. Total (CY)	Curve Widening	Summary Totals
Asphalt Surfacing	Level III/1/2" dense/PG 64-22	MP 0.000	4"	--	--	--	3.7 Tons
Road Rock	3-4"-0"	Cap Rock: MP 0.000	--	--	--	--	20
Road Rock	1-1/2"-0"	Cap Rock: 0.018 - 0.672	4"	20	691	77	768
Road Rock	1-1/2"-0"	Cap Spot Rock	---	---	---	---	70
Road Rock	6" Jaw Run	Base Rock: MP 0.649 - 0.672	9"	50	62	0	62
Road Rock	6" Jaw Run	Base Spot Rock	---	---	---	---	130
Lined Ditch	Pit-Run	MP 0.358 - 0.370	---	---	---	---	10
Culverts	6" Jaw Run	Base Spot Rock	---	---	---	---	150
Culverts	1-1/2"-0"	Bedding/Backfill	---	---	---	---	165
Fill Armor Inlet	RipRap: Class 5	MP 0.358	---	---	---	---	10
Fill Armor/Energy Dissipater Outlet	RipRap: Class 5	MP 0.358	---	---	---	---	60

ROCK VOLUMES TOTALS

ROAD SEGMENT:		4-7-11.2 (Bell Mntn Ext Rd)		MILEAGE:			0.000 - 1.277	
Application	Rock Size and Type	Location/Number	Compacted Depth	Volume per Station/Item (CY)	Approx. Total (CY)	Curve Widening (CY)	Summary Totals	
Road Rock	1-1/2"-0"	Cap Spot Rock	--	--	--	--	10	
Road Rock	6" Jaw Run	Base Spot Rock	---	---	---	---	30	
Lined Ditch	Pit-Run	MP 0.864 - 0.880	---	---	---	---	20	
Culverts	1-1/2"-0"	Cap Spot Rock	--	--	--	--	185	
Culverts	6" Jaw Run	Base Spot Rock	---	---	---	---	245	
Culverts	1-1/2"-0"	Bedding/Backfill	---	---	---	---	260	
Fill Armor Inlet	RipRap: Class 5	MP 0.071, 0.292, 0.545, 0.723, 0.880, & 1.082	---	---	---	---	55	
Fill Armor Outlet	RipRap: Class 5	MP 0.071, 0.260, 0.292, 0.545, 0.723, & 0.880	---	---	---	---	115	
Energy Dissipater Outlet	RipRap: Class 5	MP 1.245	---	---	---	---	5	
Fill Armor/Energy Dissipater Outlet	RipRap: Class 5	MP 1.082	---	---	---	---	40	

ROAD SEGMENT:		4-7-12.0A		STATION:			0+00 - 5+05	
Application	Rock Size and Type	Location	Compacted Depth	Volume per Station/Item (CY)	Approx. Total (CY)	Curve Widening (CY)	Summary Totals	
Road Rock	1-1/2"-0"	Cap Spot Rock	---	---	---	---	10	
Road Rock	6" Jaw Run	Base Spot Rock	---	---	---	---	20	

ROAD SEGMENT:		4-7-12.0B		STATION:			0+00 - 14+78	
Application	Rock Size and Type	Location/Number	Compacted Depth	Volume per Station/Item (CY)	Approx. Total (CY)	Curve Widening (CY)	Summary Totals	
Culverts	1-1/2"-0"	Cap Spot Rock	---	---	---	---	40	
Culverts	6" Jaw Run	Base Spot Rock	---	---	---	---	55	
Culverts	1-1/2"-0"	Bedding/Backfill	---	---	---	---	55	

ROAD SEGMENT:		4-7-12.1		STATION:			0+00 - 17+16	
Application	Rock Size and Type	Location/Number	Compacted Depth	Volume per Station/Item (CY)	Approx. Total (CY)	Curve Widening (CY)	Summary Totals	
Asphalt Surfacing	Level III/1/2" dense/PG 64-22	Sta. 0+22	4"	--	--	--	3.0 Tons	
Road Rock	3-4"-0"	Cap Rock: Sta. 0+22	--	--	--	--	20	
Road Rock	1-1/2"-0"	Cap Spot Rock	---	---	---	---	20	
Road Rock	3"-0" Crushed	Base Rock: Sta. 0+33 - 17+16	8"	40	673	178	851	
Road Rock	6" Jaw Run	Base Spot Rock	---	---	---	---	60	
Culverts	1-1/2"-0"	Cap Spot Rock	---	---	---	---	10	
Culverts	6" Jaw Run	Base Spot Rock	---	---	---	---	20	
Culverts	1-1/2"-0"	Bedding/Backfill	---	---	---	---	35	

ROCK VOLUMES TOTALS

ROAD SEGMENT: 4-7-12.4			MILEAGE: 0.000 - 0.050				
Application	Rock Size and Type	Location	Compacted Depth	Volume per Station/Item (CY)	Approx. Total (CY)	Curve Widening (CY)	Summary Totals
Road Rock	1-1/2"-0"	Cap Spot Rock	---	---	---	---	20

ROAD SEGMENT: 4-7-12.5			STATION: 0+00 - 3+60				
Application	Rock Size and Type	Location/Number	Compacted Depth	Volume per Station/Item (CY)	Approx. Total (CY)	Curve Widening (CY)	Summary Totals
Road Rock	1-1/2"-0"	Cap Rock: 0+00 - 3+60	4"	20	72	9	81
Road Rock	1-1/2"-0"	Cap Spot Rock	---	---	---	---	60
Road Rock	6" Jaw Run	Base Spot Rock	---	---	---	---	90

ROAD SEGMENT: 4-7-12.6			STATION: 0+00 - 1+43				
Application	Rock Size and Type	Location	Compacted Depth	Volume per Station/Item (CY)	Approx. Total (CY)	Curve Widening (CY)	Summary Totals
Road Rock	1-1/2"-0"	Cap Rock: 0+00 - 1+43	4"	20	29	2	31
Road Rock	1-1/2"-0"	Cap Spot Rock	---	---	---	---	40
Road Rock	6" Jaw Run	Base Rock: MP 0+00 - 1+43	9"	50	72	3	75
Road Rock	6" Jaw Run	Base Spot Rock	---	---	---	---	70

ROAD SEGMENT: 4-7-12.8			STATION: 0+00 - 3+88				
Application	Rock Size and Type	Location	Compacted Depth	Volume per Station/Item (CY)	Approx. Total (CY)	Curve Widening (CY)	Summary Totals
Road Rock	1-1/2"-0"	Cap Rock: 0+00 - 3+88	4"	20	78	10	88
Road Rock	1-1/2"-0"	Cap Spot Rock	---	---	---	---	40
Road Rock	6" Jaw Run	Base Rock: MP 0+00 - 3+88	9"	50	194	35	229
Road Rock	6" Jaw Run	Base Spot Rock	---	---	---	---	70

ROAD SEGMENT: 4-7-12.9			STATION: 0+00 - 15+28				
Application	Rock Size and Type	Location	Compacted Depth	Volume per Station/Item (CY)	Approx. Total (CY)	Curve Widening (CY)	Summary Totals
Road Rock	1-1/2"-0"	Cap Rock: 0+00 - 15+28	4"	20	306	39	345
Road Rock	1-1/2"-0"	Cap Spot Rock	--	--	--	--	70
Road Rock	6" Jaw Run	Base Rock: MP 0+00 - 15+28	9"	50	764	136	900
Road Rock	6" Jaw Run	Base Spot Rock	---	---	---	---	130
Culverts	1-1/2"-0"	Bedding/Backfill	---	---	---	---	45

ROAD SEGMENT: 4-7-12.11			STATION: 0+00 - 2+34				
Application	Rock Size and Type	Location	Compacted Depth	Volume per Station/Item (CY)	Approx. Total (CY)	Curve Widening (CY)	Summary Totals
Road Rock	1-1/2"-0"	Cap Spot Rock	--	--	--	--	10
Road Rock	6" Jaw Run	Base Spot Rock	---	---	---	---	20

ROCK VOLUMES TOTALS

ROAD SEGMENT: 4-7-12.13			STATION: 0+00 - 3+96				
Application	Rock Size and Type	Location	Compacted Depth	Volume per Station/Item (CY)	Approx. Total (CY)	Curve Widening (CY)	Summary Totals
Road Rock	1-1/2"-0"	Cap Spot Rock	---	---	---	---	10
Road Rock	6" Jaw Run	Base Rock: 0+00 - 3+96	9"	46	182	22	204
Road Rock	6" Jaw Run	Base Spot Rock	---	---	---	---	120

ROAD SEGMENT: 4-7-13.0			MILEAGE: 0.000 - 0.148				
Application	Rock Size and Type	Location/Number	Compacted Depth	Volume per Station/Item (CY)	Approx. Total (CY)	Curve Widening (CY)	Summary Totals
Road Rock	1-1/2"-0"	Cap Spot Rock	---	---	---	---	20
Road Rock	6" Jaw Run	Base Spot Rock	---	---	---	---	20

ROAD SEGMENT: 4-7-13.1			STATION: 0+00 - 4+15				
Application	Rock Size and Type	Location/Number	Compacted Depth	Volume per Station/Item (CY)	Approx. Total (CY)	Curve Widening (CY)	Summary Totals
Road Rock	1-1/2"-0"	Cap Spot Rock	---	---	---	---	20

ROAD SEGMENT: 4-7-13.2			STATION: 0+00 - 16+70				
Application	Rock Size and Type	Location/Number	Compacted Depth	Volume per Station/Item (CY)	Approx. Total (CY)	Curve Widening (CY)	Summary Totals
Road Rock	1-1/2"-0"	Cap Spot Rock	---	---	---	---	20
Road Rock	6" Jaw Run	Base Spot Rock	---	---	---	---	40
Culverts	1-1/2"-0"	Cap Spot Rock	---	---	---	---	25
Culverts	6" Jaw Run	Base Spot Rock	---	---	---	---	35
Culverts	1-1/2"-0"	Bedding/Backfill	---	---	---	---	35

ROAD SEGMENT: 4-7-13.4			STATION: 0+00 - 3+70				
Application	Rock Size and Type	Location/Number	Compacted Depth	Volume per Station/Item (CY)	Approx. Total (CY)	Curve Widening (CY)	Summary Totals
Road Rock	1-1/2"-0"	Cap Spot Rock	---	---	---	---	10
Road Rock	6" Jaw Run	Base Spot Rock	---	---	---	---	20

ROAD SEGMENT: 4-7-13.5			STATION: 0+00 - 4+90				
Application	Rock Size and Type	Location	Compacted Depth	Volume per Station/Item (CY)	Approx. Total (CY)	Curve Widening (CY)	Summary Totals
Road Rock	1-1/2"-0"	Cap Spot Rock	--	--	--	--	20
Culverts	1-1/2"-0"	Cap Spot Rock	---	---	---	---	20
Culverts	6" Jaw Run	Base Spot Rock	---	---	---	---	25
Culverts	1-1/2"-0"	Bedding/Backfill	---	---	---	---	25

ROCK VOLUMES TOTALS

ROAD SEGMENT: 4-7-13.6			MILEAGE: 1.000 - 0.565				
Application	Rock Size and Type	Location	Compacted Depth	Volume per Station/Item (CY)	Approx. Total (CY)	Curve Widening (CY)	Summary Totals
Road Rock	1-1/2"-0"	Cap Spot Rock	---	---	---	---	20
Road Rock	3"-0" Crushed	Base Spot Rock	---	---	---	---	70

ROAD SEGMENT: 4-7-13.7			STATION: 0+00 - 6+73				
Application	Rock Size and Type	Location	Compacted Depth	Volume per Station/Item (CY)	Approx. Total (CY)	Curve Widening (CY)	Summary Totals
Road Rock	1-1/2"-0"	Cap Spot Rock	---	---	---	---	20
Road Rock	3"-0" Crushed	Base Spot Rock	---	---	---	---	20
Culverts	1-1/2"-0"	Cap Spot Rock	---	---	---	---	15
Culverts	6" Jaw Run	Base Spot Rock	---	---	---	---	20
Culverts	1-1/2"-0"	Bedding/Backfill	---	---	---	---	20

ROAD SEGMENT: 4-7-13.9			STATION: 0+00 - 5+88				
Application	Rock Size and Type	Location	Compacted Depth	Volume per Station/Item (CY)	Approx. Total (CY)	Curve Widening (CY)	Summary Totals
Road Rock	1-1/2"-0"	Cap Spot Rock	---	---	---	---	20
Road Rock	6" Jaw Run	Base Spot Rock	---	---	---	---	50
Culverts	1-1/2"-0"	Cap Spot Rock	---	---	---	---	50
Culverts	6" Jaw Run	Base Spot Rock	---	---	---	---	65
Culverts	1-1/2"-0"	Bedding/Backfill	---	---	---	---	70
Fill Armor Inlet	RipRap: Class 5	Sta. 2+82 & 4+09	---	---	---	---	30
Fill Armor Outlet	RipRap: Class 5	Sta. 2+82 & 4+09	---	---	---	---	55

ROAD SEGMENT: 4-7-13.10			STATION: 0+00 - 1+58				
Application	Rock Size and Type	Location	Compacted Depth	Volume per Station/Item (CY)	Approx. Total (CY)	Curve Widening (CY)	Summary Totals
Road Rock	6" Jaw Run	Base Spot Rock	---	---	---	---	50

ROAD SEGMENT: 4-7-13.11			STATION: 0+00 - 4+73				
Application	Rock Size and Type	Location	Compacted Depth	Volume per Station/Item (CY)	Approx. Total (CY)	Curve Widening (CY)	Summary Totals
Road Rock	1-1/2"-0"	Cap Spot Rock	---	---	---	---	10
Road Rock	6" Jaw Run	Base Spot Rock	---	---	---	---	20
Culverts	1-1/2"-0"	Cap Spot Rock	---	---	---	---	15
Culverts	6" Jaw Run	Base Spot Rock	---	---	---	---	20
Culverts	1-1/2"-0"	Bedding/Backfill	---	---	---	---	25

ROCK VOLUMES TOTALS

ROAD SEGMENT:		4-7-14.3		STATION: 0+00 - 30+78			
Application	Rock Size and Type	Location	Compacted Depth	Volume per Station/Item (CY)	Approx. Total (CY)	Curve Widening (CY)	Summary Totals
Road Rock	1-1/2"-0"	Cap Spot Rock	---	---	---	---	15
Road Rock	6" Jaw Run	Base Spot Rock	---	---	---	---	50
Culverts	1-1/2"-0"	Cap Spot Rock	---	---	---	---	10
Culverts	6" Jaw Run	Base Spot Rock	---	---	---	---	15
Culverts	1-1/2"-0"	Bedding/Backfill	---	---	---	---	15

ROAD SEGMENT:		4-7-14.4		STATION: 0+00 - 6+45			
Application	Rock Size and Type	Location	Compacted Depth	Volume per Station/Item (CY)	Approx. Total (CY)	Curve Widening (CY)	Summary Totals
Road Rock	1-1/2"-0"	Cap Spot Rock	---	---	---	---	10
Road Rock	6" Jaw Run	Base Spot Rock	---	---	---	---	20

ROAD SEGMENT:		4-7-14.11		MILEAGE: 0.000 - 0.152			
Application	Rock Size and Type	Location	Compacted Depth	Volume per Station/Item (CY)	Approx. Total (CY)	Curve Widening (CY)	Summary Totals
Road Rock	1-1/2"-0"	Cap Spot Rock	---	---	---	---	20
Culverts	1-1/2"-0"	Cap Spot Rock	---	---	---	---	15
Culverts	6" Jaw Run	Base Spot Rock	---	---	---	---	20
Culverts	1-1/2"-0"	Bedding/Backfill	---	---	---	---	20

ROAD SEGMENT:		4-7-15.1 (Homestead Tie Rd)		MILEAGE: 0.000 - 3.173			
Application	Rock Size and Type	Location	Compacted Depth	Volume per Station/Item (CY)	Approx. Total (CY)	Curve Widening (CY)	Summary Totals
Road Rock	1-1/2"-0"	Cap Spot Rock	---	---	---	---	640
Road Rock	6" Jaw Run	Base Spot Rock	---	---	---	---	270
Culverts	1-1/2"-0"	Cap Spot Rock	---	---	---	---	245
Culverts	6" Jaw Run	Base Spot Rock	---	---	---	---	325
Culverts	1-1/2"-0"	Bedding/Backfill	---	---	---	---	345
Fill Armor Inlet	RipRap: Class 5	MP 1.764, 1.940, 2.036, & 2.957	---	---	---	---	80
Fill Armor Outlet	RipRap: Class 5	MP 0.434, 1.764, 2.138, & 2.570	---	---	---	---	70
Stabilization Wall/Energy Dissipater Outlet	RipRap: Class 5	MP 1.940 & 2.957	---	---	---	---	105
Stabilization Wall Outlet	RipRap: Class 5	MP 2.036	---	---	---	---	90

ROCK VOLUMES TOTALS

ROAD SEGMENT: 4-7-15.8			STATION: 0+00 - 6+88				
Application	Rock Size and Type	Location	Compacted Depth	Volume per Station/Item (CY)	Approx. Total (CY)	Curve Widening (CY)	Summary Totals
Road Rock	1-1/2"-0"	Cap Spot Rock	---	---	---	---	10
Road Rock	6" Jaw Run	Base Spot Rock	---	---	---	---	20
Culverts	1-1/2"-0"	Cap Spot Rock	---	---	---	---	15
Culverts	6" Jaw Run	Base Spot Rock	---	---	---	---	20
Culverts	1-1/2"-0"	Bedding/Backfill	---	---	---	---	20

ROAD SEGMENT: 4-7-15.9			STATION: 0+00 - 6+70				
Application	Rock Size and Type	Location	Compacted Depth	Volume per Station/Item (CY)	Approx. Total (CY)	Curve Widening (CY)	Summary Totals
Road Rock	1-1/2"-0"	Cap Spot Rock	---	---	---	---	10
Road Rock	6" Jaw Run	Base Spot Rock	---	---	---	---	20
Culverts	1-1/2"-0"	Cap Spot Rock	---	---	---	---	15
Culverts	6" Jaw Run	Base Spot Rock	---	---	---	---	20
Culverts	1-1/2"-0"	Bedding/Backfill	---	---	---	---	20

ROAD SEGMENT: 4-7-15.10			STATION: 0+00 - 5+90				
Application	Rock Size and Type	Location	Compacted Depth	Volume per Station/Item (CY)	Approx. Total (CY)	Curve Widening (CY)	Summary Totals
Road Rock	1-1/2"-0"	Cap Rock: Sta 0+30 - 5+90	4"	20	112	9	121
Road Rock	1-1/2"-0"	Cap Spot Rock	---	---	---	---	10
Road Rock	6" Jaw Run	Base Rock: Sta 0+30 - 5+90	9"	50	280	34	314
Road Rock	6" Jaw Run	Base Spot Rock	---	---	---	---	20

ROAD SEGMENT: 4-7-15.11			STATION: 0+00 - 3+30				
Application	Rock Size and Type	Location	Compacted Depth	Volume per Station/Item (CY)	Approx. Total (CY)	Curve Widening (CY)	Summary Totals
Application	Rock Size and Type	Location	Compacted Depth	Volume per Station/Item (CY)	Approx. Total (CY)	Curve Widening (CY)	Summary Totals
Road Rock	1-1/2"-0"	Cap Spot Rock	---	---	---	---	10
Road Rock	6" Jaw Run	Base Spot Rock	---	---	---	---	20

ROAD SEGMENT: 4-7-23.3			STATION: 0+00 - 3+55				
Application	Rock Size and Type	Location	Compacted Depth	Volume per Station/Item (CY)	Approx. Total (CY)	Curve Widening (CY)	Summary Totals
Road Rock	1-1/2"-0"	Cap Spot Rock	---	---	---	---	10
Road Rock	6" Jaw Run	Base Spot Rock	---	---	---	---	20

ROCK VOLUMES TOTALS

ROAD SEGMENT: 4-7-23.4			STATION: 0+00 - 3+65				
Application	Rock Size and Type	Location	Compacted Depth	Volume per Station/Item (CY)	Approx. Total (CY)	Curve Widening (CY)	Summary Totals
Road Rock	1-1/2"-0"	Cap Spot Rock	---	---	---	---	10
Road Rock	6" Jaw Run	Base Rock: Sta 0+00 - 2+15	9"	50	108	5	113
Road Rock	6" Jaw Run	Base Spot Rock	---	---	---	---	20

ROAD SEGMENT: 4-7-24.0 (Homestead Road)			MILEAGE: 0.000 - 1.364				
Application	Rock Size and Type	Location	Compacted Depth	Volume per Station/Item (CY)	Approx. Total (CY)	Curve Widening (CY)	Summary Totals
Road Rock	1-1/2"-0"	Cap Spot Rock	---	---	---	---	75
Road Rock	3"-0"	Base Spot Rock	---	---	---	---	90
Road Rock	6" Jaw Run	Base Spot Rock	---	---	---	---	100
Culverts	1-1/2"-0"	Cap Spot Rock	---	---	---	---	105
Culverts	6" Jaw Run	Base Spot Rock	---	---	---	---	135
Culverts	1-1/2"-0"	Bedding/Backfill	---	---	---	---	135
Fill Armor Outlet	RipRap: Class 5	MP 0.717	---	---	---	---	40
Energy Dissipater Outlet	RipRap: Class 5	MP 0.424	---	---	---	---	10

ROAD SEGMENT: 4-7-24.0B			STATION: 0+00 - 20+10				
Application	Rock Size and Type	Location	Compacted Depth	Volume per Station/Item (CY)	Approx. Total (CY)	Curve Widening (CY)	Summary Totals
Culverts	1-1/2"-0"	Cap Spot Rock	---	---	---	---	75
Culverts	6" Jaw Run	Base Spot Rock	---	---	---	---	100
Culverts	1-1/2"-0"	Bedding/Backfill	---	---	---	---	100
Fill Armor Inlet	RipRap: Class 5	Sta. 11+78	---	---	---	---	10
Fill Armor Outlet	RipRap: Class 5	Sta. 11+78	---	---	---	---	10

ROAD SEGMENT: 4-7-24.1			MILEAGE: 0.000 - 0.304				
Application	Rock Size and Type	Location	Compacted Depth	Volume per Station/Item (CY)	Approx. Total (CY)	Curve Widening (CY)	Summary Totals
Road Rock	1-1/2"-0"	Cap Spot Rock	---	---	---	---	10
Culverts	1-1/2"-0"	Cap Spot Rock	---	---	---	---	50
Culverts	6" Jaw Run	Base Spot Rock	---	---	---	---	65
Culverts	1-1/2"-0"	Bedding/Backfill	---	---	---	---	65
Fill Armor Outlet	RipRap: Class 5	MP 0.085	---	---	---	---	10

ROCK VOLUMES TOTALS

ROAD SEGMENT:			4-7-24.2		MILEAGE:			0.000 - 0.163	
Application	Rock Size and Type	Location	Compacted Depth	Volume per Station/Item (CY)	Approx. Total (CY)	Curve Widening (CY)	Summary Totals		
Road Rock	1-1/2"-0"	Cap Spot Rock	---	---	---	---	10		
Road Rock	6" Jaw Run	Base Spot Rock	---	---	---	---	30		

ROAD SEGMENT:			4-7-27.2		MILEAGE:			0.000 - 0.771	
Application	Rock Size and Type	Location	Compacted Depth	Volume per Station/Item (CY)	Approx. Total (CY)	Curve Widening (CY)	Summary Totals		
Road Rock	1-1/2"-0"	Cap Rock: MP 0.000 - 0.771	4"	21	855	138	993		
Road Rock	1-1/2"-0"	Cap Spot Rock	--	--	--	--	30		
Road Rock	6" Jaw Run	Base Rock: MP 0.676 - 0.771	9"	53	266	40	306		
Road Rock	6" Jaw Run	Base Spot Rock	---	---	---	---	30		
Lined Ditch	Pit-Run	MP 0.293 - 0.325	---	---	---	---	15		
Culverts	6" Jaw Run	Base Spot Rock	---	---	---	---	80		
Culverts	1-1/2"-0"	Bedding/Backfill	---	---	---	---	100		
Fill Armor Outlet	RipRap: Class 5	MP 0.235	---	---	---	---	10		
Fill Armor/Energy Dissipater Outlet	RipRap: Class 5	MP 0.511	---	---	---	---	25		

ROAD SEGMENT:			4-7-36.0 (Willamina Cr Rd)		MILEAGE:			0.000 - 5.558	
Application	Rock Size and Type	Location	Compacted Depth	Volume per Station/Item (CY)	Approx. Total (CY)	Curve Widening (CY)	Summary Totals		
Road Rock	1-1/2"-0"	Cap Rock: MP 0.466 - 0.799, MP 0.995 - 1.039, MP 1.119 - 1.155, MP 1.247 - 1.452, MP 2.030 - 2.116, & 2.357 - 2.433	4"	23	947	47	994		
Road Rock	1-1/2"-0"	Cap Spot Rock	---	---	---	---	1,110		
Road Rock	6" Jaw Run	Base Spot Rock	---	---	---	---	530		
Lined Ditch	Pit-Run	MP 0.252 - 0.348 & MP 1.394 - 1.421	---	---	---	---	50		
Culverts	1-1/2"-0"	Cap Spot Rock	---	---	---	---	265		
Culverts	6" Jaw Run	Base Spot Rock	---	---	---	---	470		
Culverts	1-1/2"-0"	Bedding/Backfill	---	---	---	---	465		
Fill Armor Inlet	RipRap: Class 5	MP 0.252, 2.798, & 5.402	---	---	---	---	25		
Fill Armor Outlet	RipRap: Class 5	MP 2.186 & 5.402	---	---	---	---	30		
Fill Armor/Stabilization Wall Outlet	RipRap: Class 5	MP 1.141	---	---	---	---	60		
Stabilization Wall Outlet	RipRap: Class 5	MP 2.375 & MP 2.786 - 2.798	---	---	---	---	495		

ROCK VOLUMES TOTALS

ROAD SEGMENT:			5-7-3.0		STATION:			0+00 - 2+17	
Application	Rock Size and Type	Location	Compacted Depth	Volume per Station/Item (CY)	Approx. Total (CY)	Curve Widening (CY)	Summary Totals		
Application	Rock Size and Type	Location	Compacted Depth	Volume per Station/Item (CY)	Approx. Total (CY)	Curve Widening (CY)	Summary Totals		
Road Rock	1-1/2"-0"	Cap Spot Rock	--	--	--	--	10		
Road Rock	6" Jaw Run	Base Rock: Sta. 0+00 - 2+17	9"	46	100	10	110		
Road Rock	6" Jaw Run	Base Spot Rock	---	---	---	---	20		

ROAD SEGMENT:			5-7-11.0		STATION:			0+00 - 2+80	
Application	Rock Size and Type	Location	Compacted Depth	Volume per Station/Item (CY)	Approx. Total (CY)	Curve Widening (CY)	Summary Totals		
Application	Rock Size and Type	Location	Compacted Depth	Volume per Station/Item (CY)	Approx. Total (CY)	Curve Widening (CY)	Summary Totals		
Road Rock	1-1/2"-0"	Cap Spot Rock	---	---	---	---	10		
Road Rock	6" Jaw Run	Base Spot Rock	---	---	---	---	20		

ROAD SEGMENT:			5-7-11.1		STATION:			0+00 - 5+35	
Application	Rock Size and Type	Location	Compacted Depth	Volume per Station/Item (CY)	Approx. Total (CY)	Curve Widening (CY)	Summary Totals		
Application	Rock Size and Type	Location	Compacted Depth	Volume per Station/Item (CY)	Approx. Total (CY)	Curve Widening (CY)	Summary Totals		
Road Rock	1-1/2"-0"	Cap Spot Rock	--	--	--	--	10		
Road Rock	6" Jaw Run	Base Spot Rock	---	---	---	---	20		

ROAD SEGMENT:			5-7-15.0		MILEAGE:			0.000 - 1.386	
Application	Rock Size and Type	Location	Compacted Depth	Volume per Station/Item (CY)	Approx. Total (CY)	Curve Widening (CY)	Summary Totals		
Application	Rock Size and Type	Location	Compacted Depth	Volume per Station/Item (CY)	Approx. Total (CY)	Curve Widening (CY)	Summary Totals		
Road Rock	1-1/2"-0"	Cap Spot Rock	---	---	---	---	20		
Road Rock	6" Jaw Run	Base Spot Rock	---	---	---	---	180		
Culverts	1-1/2"-0"	Cap Spot Rock	---	---	---	---	185		
Culverts	6" Jaw Run	Base Spot Rock	---	---	---	---	265		
Culverts	1-1/2"-0"	Bedding/Backfill	---	---	---	---	225		
Fill Armor Outlet	RipRap: Class 5	MP 0.860	---	---	---	---	20		

ROAD SEGMENT:			5-7-15.1		STATION:			0+00 - 23+95	
Application	Rock Size and Type	Location	Compacted Depth	Volume per Station/Item (CY)	Approx. Total (CY)	Curve Widening (CY)	Summary Totals		
Application	Rock Size and Type	Location	Compacted Depth	Volume per Station/Item (CY)	Approx. Total (CY)	Curve Widening (CY)	Summary Totals		
Road Rock	1-1/2"-0"	Cap Spot Rock	--	--	--	--	10		
Road Rock	6" Jaw Run	Base Spot Rock	---	---	---	---	20		

ROCK VOLUMES TOTALS

ROAD SEGMENT:			5-7-15.2		STATION:			0+00 - 11+52	
Application	Rock Size and Type	Location	Compacted Depth	Volume per Station/Item (CY)	Approx. Total (CY)	Curve Widening (CY)	Summary Totals		
Road Rock	1-1/2"-0"	Cap Spot Rock	---	---	---	---	10		
Road Rock	6" Jaw Run	Base Spot Rock	---	---	---	---	20		

ROAD SEGMENT:			5-7-15.3		STATION:			0+00 - 6+66	
Application	Rock Size and Type	Location	Compacted Depth	Volume per Station/Item (CY)	Approx. Total (CY)	Curve Widening (CY)	Summary Totals		
Road Rock	1-1/2"-0"	Cap Spot Rock	--	--	--	--	10		
Road Rock	6" Jaw Run	Base Spot Rock	---	---	---	---	20		

ROAD SEGMENT:			5-7-15.4		STATION:			0+00 - 9+38	
Application	Rock Size and Type	Location	Compacted Depth	Volume per Station/Item (CY)	Approx. Total (CY)	Curve Widening (CY)	Summary Totals		
Road Rock	1-1/2"-0"	Cap Spot Rock	--	--	--	--	10		
Road Rock	6" Jaw Run	Base Spot Rock	---	---	---	---	20		

ROAD SEGMENT:			5-7-22.0/Indian Creek Rd		MILEAGE:			0.000 - 3.466	
Application	Rock Size and Type	Location	Compacted Depth	Volume per Station/Item (CY)	Approx. Total (CY)	Curve Widening (CY)	Summary Totals		
Road Rock	6" Jaw Run	Base Spot Rock	---	---	---	---	240		
Culverts	1-1/2"-0"	Cap Spot Rock	---	---	---	---	320		
Culverts	6" Jaw Run	Base Spot Rock	---	---	---	---	390		
Culverts	1-1/2"-0"	Bedding/Backfill	---	---	---	---	395		
Fill Armor Outlet	RipRap: Class 5	MP 1.497 & 1.804	---	---	---	---	50		
Energy Dissipater Outlet	RipRap: Class 5	MP 1.305	---	---	---	---	10		

**United States Department of Interior
BUREAU OF LAND MANAGEMENT
NORTHWEST OREGON DISTRICT - OREGON
Whip Up Flats Quarry Plan - Appendix C1**

Coastal Chrome Timber Sale
Contract NO ORN04-TS-2023-0401
Appendix C1

T. 04S. R. 07W. Sections 1, 12, 13, 14, 15, 23, & 24 W.M. - NORTHWEST OREGON DISTRICT - OREGON

T. 04S. R. 06W Sections 6, 7, & 18 W.M. - NORTHWEST OREGON DISTRICT - OREGON

T. 05S. R. 07W. Sections 11 & 15 W.M. - NORTHWEST OREGON DISTRICT - OREGON

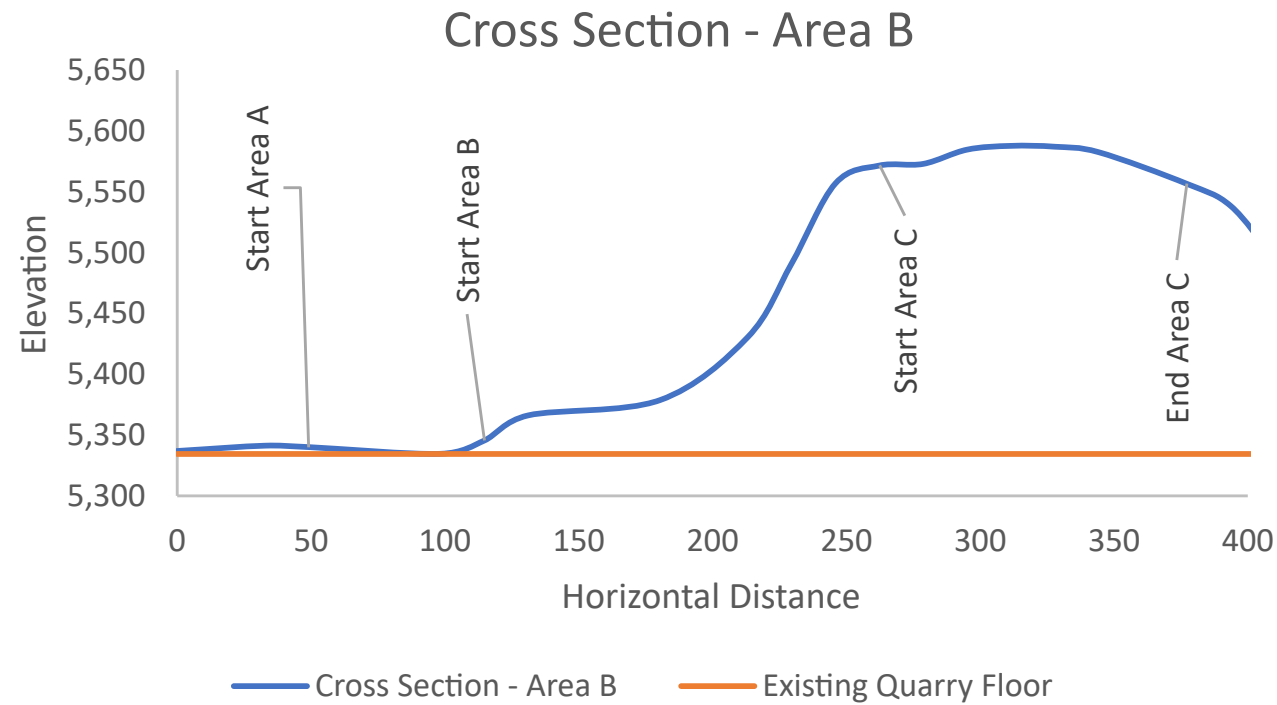

Whip Up Flats Quarry Specifications

Area A - Existing Quarry Floor. Utilize for crushing operations and temporary stockpile location.

Area B - Designated Coastal Chrome Timber Sale Development Area.

Area C - Designated stockpile site and designated waste area location for all overburden, reject material, and organic debris.

Area D - Potential additional stockpile sites and waste area locations upon approval of Authorized Officer.

Whip Up Flats Quarry Specifications may be changed at the discretion of the Authorized Officer.

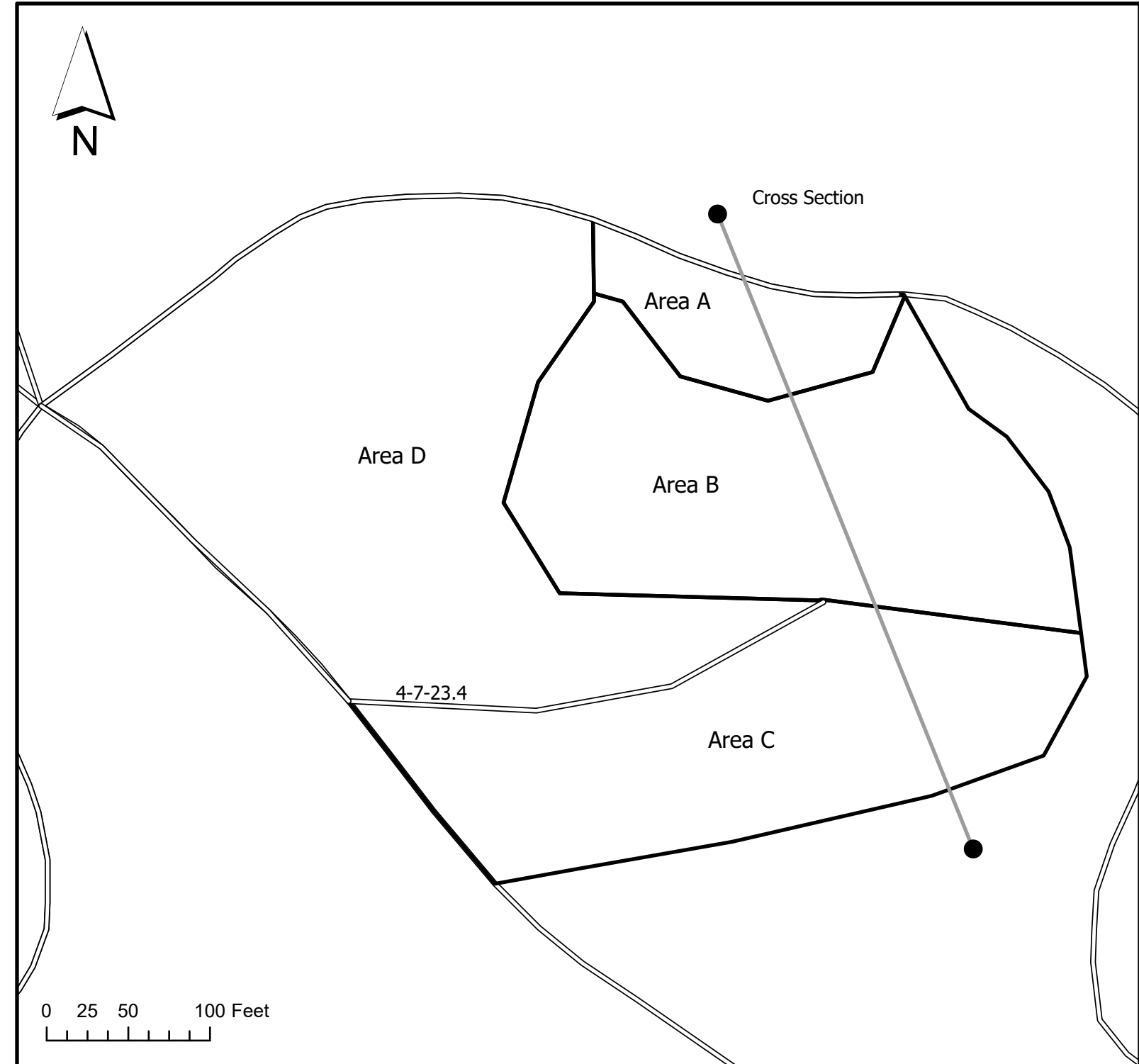

No warranty is made by the Bureau of Land Management as to the accuracy, reliability, or completeness of these data for individual or aggregate use with other data. Original data were compiled from various sources and may be updated without notification.
Prepared By: Austin Bettis

**United States Department of Interior
BUREAU OF LAND MANAGEMENT
NORTHWEST OREGON DISTRICT - OREGON**

Coastal Chrome Timber Sale
Contract NO ORN04-TS-2023-0401
Appendix C1

Whip Up Flats Quarry Plan - Appendix C1

T. 04S. R. 07W. Sections 1, 12, 13, 14, 15, 23, & 24 W.M. - NORTHWEST OREGON DISTRICT - OREGON

T. 04S. R. 06W Sections 6, 7, & 18 W.M. - NORTHWEST OREGON DISTRICT - OREGON

T. 05S. R. 07W. Sections 11 & 15 W.M. - NORTHWEST OREGON DISTRICT - OREGON

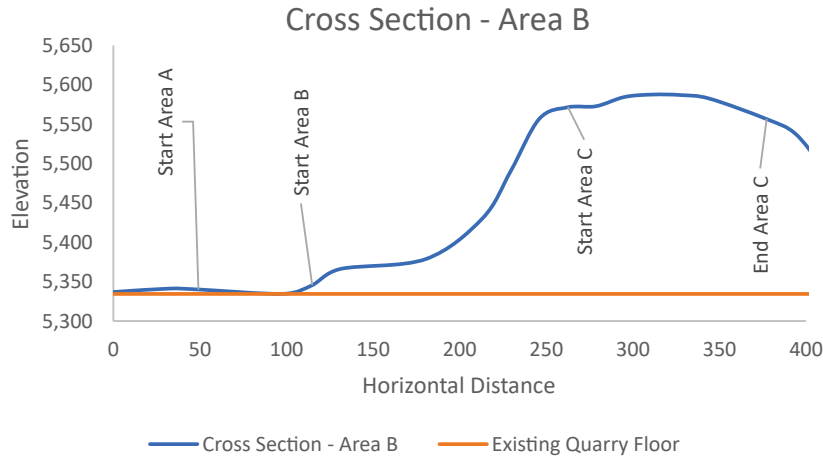

Whip Up Flats Quarry Specifications

Area A - Existing Quarry Floor. Utilize for crushing operations and temporary stockpile location.

Area B - Designated Coastal Chrome Timber Sale Development Area.

Area C - Designated stockpile site and designated waste area location for all overburden, reject material, and organic debris.

Area D - Potential additional stockpile sites and waste area locations upon approval of Authorized Officer.

Whip Up Flats Quarry Specifications may be changed at the discretion of the Authorized Officer.

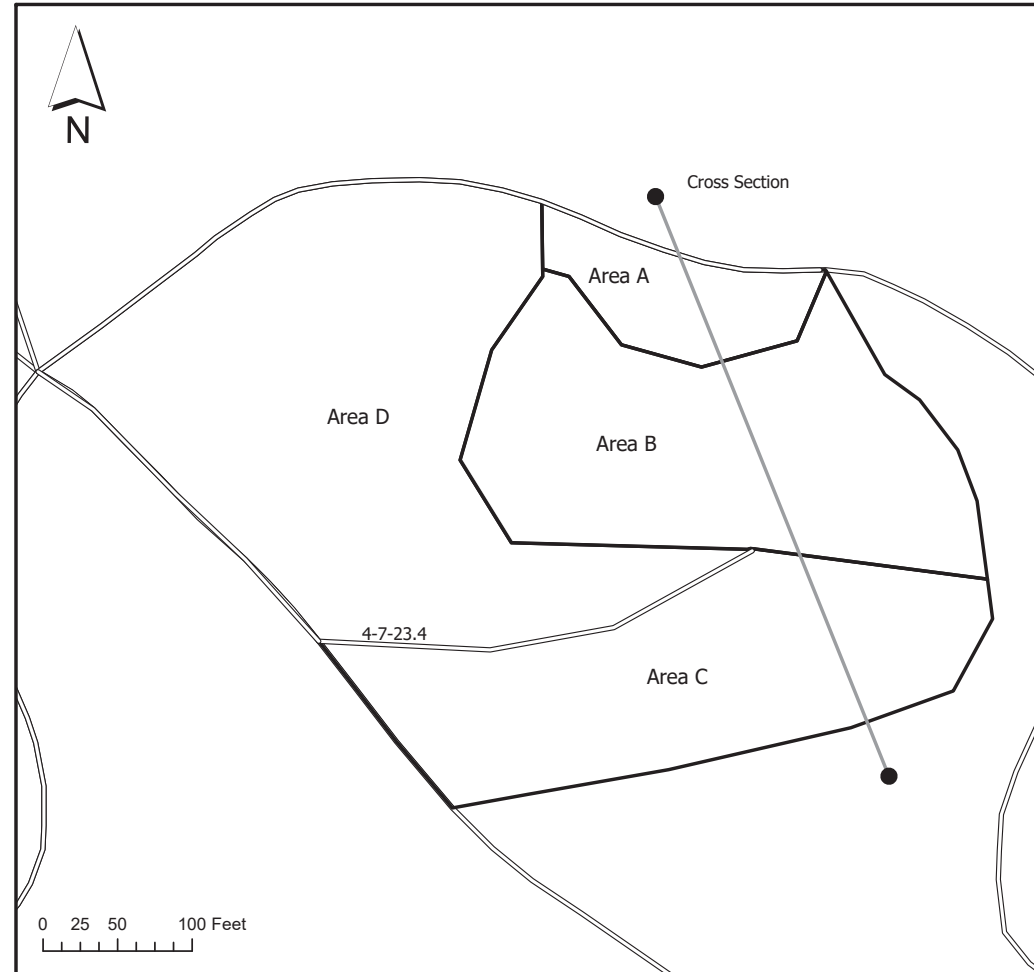



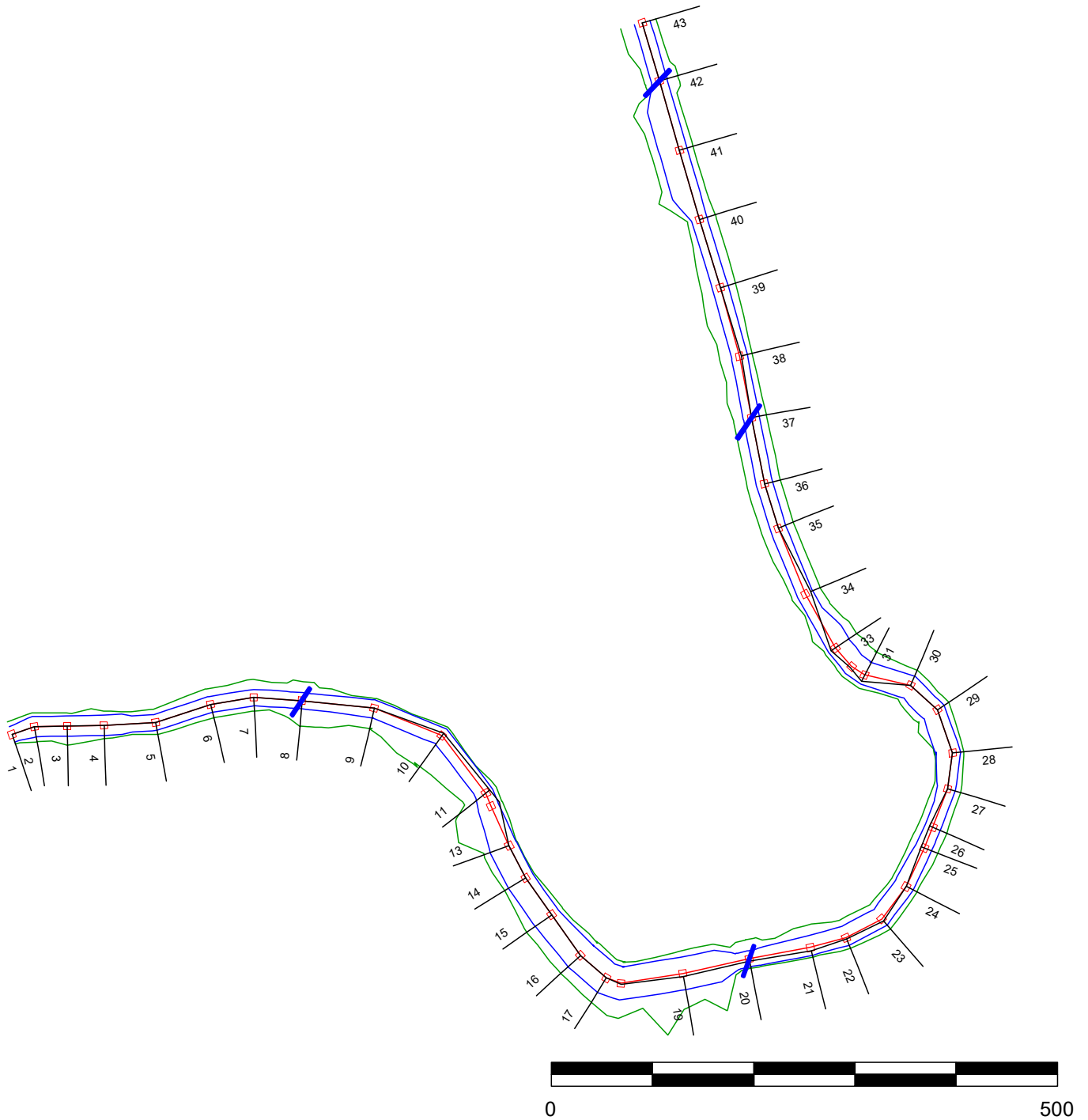

No warranty is made by the Bureau of Land Management as to the accuracy, reliability, or completeness of these data for individual or aggregate use with other data. Original data were compiled from various sources and may be updated without notification.
Prepared By: Austin Bettis

United States Department of Interior
BUREAU OF LAND MANAGEMENT
NORTHWEST OREGON DISTRICT - OREGON
EXHIBIT C - APPENDIX C-2

4-6-7.4



Legend

 Plan L-line Location	 Plan Road Edges
 Plan P-line Location	 Plan Culverts
 Plan Slope Stakes	

United States Department of Interior
BUREAU OF LAND MANAGEMENT
NORTHWEST OREGON DISTRICT - OREGON
EXHIBIT C - APPENDIX C-2

4-6-7.4

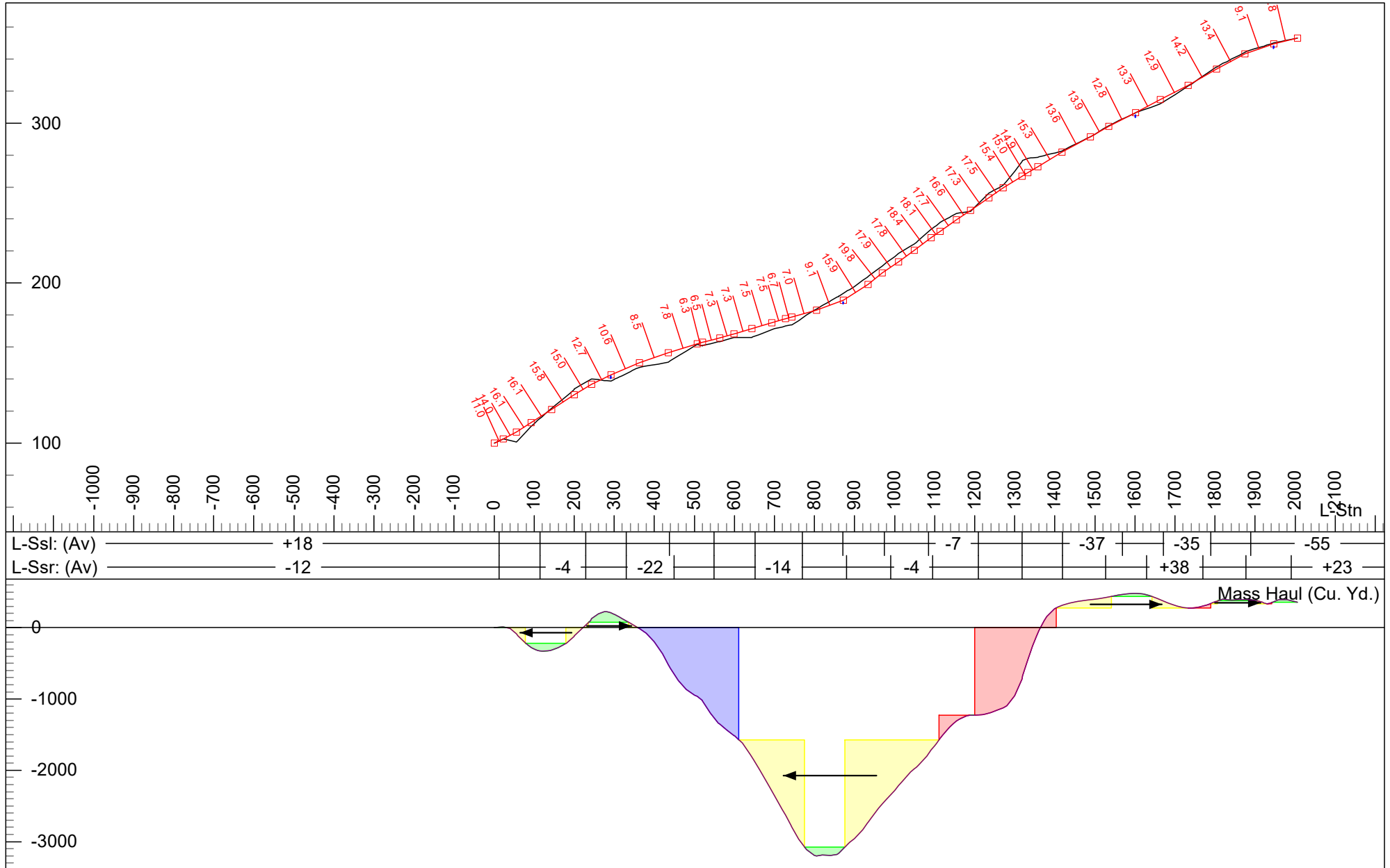

United States Department of Interior
 BUREAU OF LAND MANAGEMENT
 NORTHWEST OREGON DISTRICT - OREGON
 EXHIBIT C - APPENDIX C-2

4-6-7.4

Index	Azimuth deg.	H.Offset ft.	SD ft.	L-Stn ft.	Cut Dp. ft.	Grade %
1	8	0.0	23.4	0.0	0.0	11
2	26	0.0	32.8	23.3	0.0	14
3	26	0.0	37.1	55.7	-6.5	16
4	24	0.0	51.6	92.3	-2.5	16
5	9	0.0	57.9	143.3	0.5	16
6	18	0.0	43.8	200.4	3.5	15
7	31	0.0	48.1	243.7	3.5	13
8	33	0.0	72.2	291.4	-4.0	11
9	49	0.0	72.3	363.2	-3.0	9
10	80	3.0	71.8	435.3	-5.9	8
11	96	5.0	13.7	506.9	-0.5	6
12	92	9.0	43.1	520.5	-1.9	6
13	90	0.0	36.0	563.6	-2.5	7
14	82	0.0	44.7	599.4	-2.3	7
15	82	0.0	49.4	644.0	-5.5	7
16	68	0.0	34.0	693.3	-4.3	7
17	46	0.0	15.5	727.2	-4.8	7
18	18	-1.0	61.8	742.7	-4.9	7
19	15	-3.0	67.4	804.3	0.6	9
20	17	-2.0	62.3	871.5	4.3	16
21	12	-3.5	37.2	933.0	4.9	20
22	359	-1.0	40.5	969.5	4.4	18
23	334	-3.0	40.6	1009.4	5.2	18
24	322	0.0	42.8	1049.4	4.0	18
25	320	3.0	22.6	1091.5	5.5	18
26	318	3.5	41.4	1113.7	5.5	18
27	305	0.0	36.2	1154.4	4.0	17
28	278	0.0	46.0	1190.1	-0.5	17
29	249	0.0	36.5	1235.4	3.0	17
30	220	0.0	46.8	1271.3	1.8	15
31	240	7.0	15.7	1317.6	9.1	15
32	256	2.0	24.4	1333.1	8.9	15
33	268	5.0	61.8	1357.3	5.9	15
34	275	-6.0	70.8	1418.3	0.6	14
35	280	0.0	46.5	1488.5	0.0	14
36	286	0.0	67.1	1534.6	0.5	13
37	286	0.0	62.3	1601.1	0.0	13
38	282	-2.0	71.0	1662.9	-2.5	13
39	280	0.0	71.2	1733.3	-0.5	14
40	281	0.0	71.7	1803.8	1.5	13
41	281	0.0	71.5	1874.9	1.3	9
42	281	0.0	60.1	1946.1	0.5	6
43	281	0.0		2006.1	0.0	

ROAD MAINTENANCE SPECIFICATIONS

General road maintenance specifications are designated by numeric symbols according to the type of work performed as follows:

SECTION	DESCRIPTION
3000	General
3100	Operational Maintenance
3200	Seasonal Maintenance
3300	Final Maintenance
3400	Other Maintenance
3500	Decommissioning

GENERAL - 3000

- 3001 The Purchaser shall be required to maintain all roads as shown on the Exhibit E maps of this contract in accordance with Sections 3000, 3100, 3200, 3300, 3400, and 3500 of this exhibit.
- 3001a The Purchaser shall be required to provide maintenance on roads in accordance with Subsections 3405, 3405a, 3405b, 3406b.
- 3002 The Purchaser shall maintain the cross section of existing dirt or graveled roads to the existing geometric standards. Any roads required to be constructed, improved, or renovated under terms of this contract shall be maintained to the geometric standards required in Exhibit C of this contract.
- 3003 The minimum required maintenance on any Purchaser maintained roads shall include the provisions specified in Subsections 3101, 3104, and 3105.
- 3004 The Purchaser shall be responsible for providing timely maintenance and cleanup on any roads with logging units substantially completed prior to moving operations to other roads. The maximum length of non-maintained or non-cleanup of the road prism shall not exceed the sum of one (1) mile at any time. Release of maintenance requirements may be granted, upon written request, when the conditions specified in Sections 3300 and 3400 are met satisfactorily.

OPERATIONAL MAINTENANCE - 3100

3101 The Purchaser shall blade and shape the road surface and shoulders with a motor grader, when directed by the Authorized Officer. Banks shall not be undercut. Back blading with tractors or similar equipment will be allowed only around landings and other areas when approved by the Authorized Officer.

3102 The Purchaser shall furnish and place 1,395 cu.yds. of aggregate conforming to the requirements in Sections 1200 of Exhibit C of this contract on the roadway at locations and in the amounts designated by the Authorized Officer. The Purchaser shall furnish and stockpile 675 cu. yds. of aggregate conforming to the requirements of in Sections 1200 of Exhibit C of this contract at locations designated by the Authorized Officer.

1,390 cu.yds. - To be placed on BLM controlled roads as directed by Authorized Officer (maintenance rock: Sections 42.z.).

675 cu. yds. – To be stockpiled as directed by Authorized Officer (maintenance rock: Sections 42.z.).

5 cu yds – To be placed on non-BLM controlled roads as directed by the Authorized Officer (maintenance rock: Section 42.ee.)

This aggregate shall be used to repair surface failures and areas of depleted surface depth excluding damages covered by Section 12 of this contract. The aggregate shall be furnished, hauled, placed, spread, and compacted by use of dump trucks, water trucks, and motor grader or similar equipment.

3104 The purchaser shall perform other road cleanup including removal of debris, fallen timber, bank slough, and slides which can practicably be accomplished by a motor grader, rubber tired front end bucket loader, rubber tired backhoe or comparable equipment, and by the use of hand tools.

3104a Removal of bank slough and slide material includes placement of material at the nearest designated, suitable disposal site where material cannot erode into streams, lakes, or reservoirs or cause undue damage to road fill slopes which have been planted or mulched to control soil erosion as directed by the Authorized Officer.

3104b The Purchaser shall be responsible for removal of all slides or slough, up to fifteen station yards in quantity, at any one site. This work includes unlimited multiple sites on all roads required to be maintained by the purchaser.

Prior to removal of any slough or slide material exceeding fifteen station yards at any one site, the Purchaser and the Authorized Officer or their Authorized Representatives shall agree in writing, in the field, to the quantity of material, method of disposal, and the disposal site. Work may commence immediately after agreement.

Upon completion of agreed upon work, a reduction in timber sale purchase price will be made to offset the cost of the work, based on current BLM Road Cost Guide. Adjustments in purchase price for completed work shall be made as necessary and no less than once per year when actual work is ongoing.

3105 The Purchaser shall be responsible for maintaining normal flow in drainage structures. This includes cleaning out drainage ditches, catch basins, clearing pipe inverts of sediment and other debris lodged in the barrel of the pipe, and maintaining water dips and waterbars using equipment specified in Subsection 3104 and other culvert cleaning and flushing equipment.

3108 The Purchaser shall avoid fouling gravel or bituminous surfaces through covering with earth and debris from side ditches, slides or other sources. The Purchaser shall also avoid blading surfacing material off the running surface of the roadway. (Skidding of logs on the roadway in or outside designated logging units is not authorized without prior written approval by the Authorized Officer. Repair required caused by such skidding activity is not considered maintenance and shall be repaired at the Purchaser's expense.)

SEASONAL MAINTENANCE - 3200

- 3201 The Purchaser shall perform preventative maintenance at the end of Purchaser's hauling each season and during non-hauling periods which occur between other operations on the contract area. This includes requirements specified in Section 3100.
- 3202 The purchaser shall perform and complete maintenance specified in Sections 3000, 3100, and 3200 on all roads maintained by him, during times when there is a low potential to deliver sediment to streams, as determined by Authorized Officer, and as specified in Subsection 3203, after initial commencement of construction or logging operations. Thereafter, all roads shall have continuous preventive maintenance and road cleanup. This includes all roads used and not used during the preceding operating seasons.
- 3203 The Purchaser shall complete road cleanup and maintenance, as specified in Section 3100, at the completion of logging operations on any roads located in an area separate from the area where logging activities will resume.
- 3204 The Purchaser shall be responsible for performing post storm inspections and maintenance during the winter season to minimize erosion and potential road or watershed damage.

FINAL MAINTENANCE - 3300

- 3301 The Purchaser shall complete final maintenance and/or damage repairs on all roads used under terms of their contract within thirty (30) calendar days following the completion of hauling and in accordance with Sec. 16(b) of this contract. This work shall include any maintenance and/or damage repairs specified in Sections 3000, 3100, and 3200 necessary to meet the conditions specified in Subsection 3002 and shall be executed in accordance with Subsection 3302 of this section.
- The Authorized Officer may grant acceptance of Purchaser's maintenance responsibility in part where certain individual roads or road segments are no longer of any use to the Purchaser's remaining removal operations, providing that all contract requirements as specified under Sec. 16(b), Special Provisions (Sections 3000, 3100, 3200 and 3300 of the maintenance specifications) have been completed and a relinquishment of cutting and removal rights on cutting units tributary to these roads is signed by the Purchaser. Request for partial acceptance must be submitted in writing by the Purchaser.
- 3302 The Purchaser shall perform final road maintenance only when weather or soil moisture conditions are suitable for normal maintenance equipment operations as determined by the Authorized Officer.

If final maintenance is delayed after the date required in Subsection 3301 of this contract by adverse soil moisture or unsuitable equipment operating conditions, the Purchaser will be notified by the Authorized Officer when soil moisture and equipment operating conditions are suitable. The Purchaser shall then be required to complete final maintenance within 30 days.

OTHER MAINTENANCE - 3400

- 3401 The Purchaser shall repair any damage to road surfaces that was specified under Subsection 3108. This repair includes restoring the roadway to the designed standard and replacement of surfacing with approved surface material. This repair is not limited to use of equipment specified in Subsection 3104.
- 3402 The Purchaser shall be permitted to remove ice and snow from roads authorized for use under this contract only when prior written approval has been secured from the Authorized Officer. The Purchaser shall submit a written request for permission to remove ice and snow in advance of the date operations are to begin.
- Upon receiving written authorization for ice or snow removal, the Purchaser will perform the work according to the conditions and equipment requirements set forth in the authorization.

DECOMMISSIONING – 3500

- 3501 Decommissioning on the following roads shall consist of removing cross drains and draw culverts. Work includes subsoiling, spread government supplied grass seed, installing non-drivable waterbars, scattering slash, removing culverts, and blocking roads from access by vehicles. This work is *not* required for road acceptance under Section 18 of this contract.

Road No or Site	From Sta/MP	To Sta/MP	Length
4-6-7.5	0+00	11+40	1,140 feet
4-6-18.1	0+00	9+28	928 feet
4-6-18.2	0+00	5+45	545 feet
4-7-12.0B	0+00	14+78	1,478 feet
4-7-12.10	0+00	3+85	385 feet
4-7-12.11	0+00	2+34	234 feet
4-7-12.12	0+00	9+10	910 feet
4-7-13.2	14+30	16+70	240 feet
4-7-13.4	0+00	3+70	370 feet

4-7-13.11	0+00	4+73	473 feet
4-7-14.4	0+00	6+45	645 feet
4-7-15.8	0+00	6+88	688 feet
*4-7-15.9	0+00	6+70	670 feet
*4-7-15.11	0+00	3+30	330 feet
4-7-23.3	0+00	3+55	355 feet
5-7-11.2	0+00	9+85	985 feet
5-7-15.3	0+00	6+66	666 feet
5-7-15.4	0+00	9+38	938 feet

* - These roads utilize portions of established OHV trails and are to be decommissioned in such a fashion to preserve the trails, trail signs, access to trails, and drainage as directed by the Authorized Officer.

3501c

Decommissioning on the following roads shall consist of removing cross drains and draw culverts. Work includes installing non-drivable waterbars, spread government supplied grass seed, and blocking roads from access by vehicles. This work is *not* required for road acceptance under Section 18 of this contract.

Road No or Site	From Sta/MP	To Sta/MP	Length
4-6-7.4	0+00	41+62	4,162 feet
4-7-1.4	0.649	0.672	0.023 miles
4-7-12.8	0+00	3+88	388 feet
4-7-12.9	0+00	15+28	1,528 feet
4-7-12.13	0+00	3+96	396 feet
4-7-23.4	0+00	3+65	365 feet
4-7-24.0	1.185	1.364	0.179 miles
4-7-24.0B	0+00	20+10	2,010 feet
4-7-36.0	5.357	5.558	0.201 miles
5-7-11.0	0+00	2+80	280 feet
5-7-15.0	1.091	1.386	0.295 miles
5-7-15.1	0+00	23+95	2,395 feet
5-7-15.2	0+00	11+52	1,152 feet

3501d

Stabilization of the following roads shall consist of installing drivable waterbars/waterdips (as directed). This work is *not* required for road acceptance under Section 18 of this contract.

Road No or Site	From Sta/MP	To Sta/MP	Length
4-7-12.0A	0+00	5+05	505 feet
4-7-13.1	0+00	4+15	415 feet
4-7-13.2	0+00	14+30	1,430 feet
4-7-13.5	0+00	4+90	490 feet
4-7-13.6	0.000	0.565	0.565 miles
4-7-13.7	0+00	6+73	673 feet
4-7-24.2	0.000	0.163	0.163 miles
5-7-11.1	0+00	5+35	535 feet

3504 Decommissioning and Stabilization work shall be completed after all harvesting activities requiring that road segment have ceased, unless otherwise authorized in writing by the Authorized Officer. All decommissioning and stabilization work shall be performed during times when there is a low potential to deliver sediment to streams, as determined by the Authorized Officer (except in-stream work, which is in North Yamhill River Watershed:

From	To
July 15	September 30

3505 Where draw crossing fill material is to be excavated and removed, the finished bottom of draw profile shall be reestablished to its original channel grade, and resulting adjacent banks shall be constructed to a 2:1 backslope ratio.

3507 Culverts and Inlet Markers removed during decommissioning shall become the property of the BLM. All culverts and bands removed from the roadbed shall be recovered in such a manner as to preserve the pipe from rips and holes. The Purchaser shall be responsible for delivering culvert materials to the BLM Cedar Creek Storage Facility (SW¼ sec. 5, T. 3 S., R. 6 W., WM.) and for payment of any fees required. This task shall be done prior to termination of this contract.

3509 Decommissioned roads shall have access blocked with barricades as shown on Exhibit C page 51. Stumps and woody debris used in the construction of barricades shall be material piled and stored during the clearing and grubbing process of road construction.

3511 Subsoiling shall be accomplished by using excavator attachments, log loader tongs, or other acceptable equipment capable of de-compacting the soil to a depth of 18 inches. The full width of the roadbed shall be loosened by the subsoiling operation, with no portion of the bed having been left at the original compacted

density. Ripper entries into the roadbed shall be spaced where total subgrade subsoiling is accomplished.

3513

Waterbars (drivable and non-drivable)/Waterdips shall be installed across full width of roadway at locations marked in the field by Authorized Officer and constructed to the dimensions of the waterbar detail on Page 51 of Exhibit C.

**United States Department of Interior
BUREAU OF LAND MANAGEMENT
NORTHWEST OREGON DISTRICT - OREGON
Road Plan Map**

Coastal Chrome Timber Sale
Contract NO ORN04-TS-2023-0402
Exhibit E
Page 1 of 9

T. 04S. R. 07W. Sections 1, 12, 13, 14, 15, 23, & 24 W.M. - NORTHWEST OREGON DISTRICT - OREGON
T. 04S. R. 06W Sections 6, 7, & 18 W.M. - NORTHWEST OREGON DISTRICT - OREGON
T. 05S. R. 07W. Sections 11 & 15 W.M. - NORTHWEST OREGON DISTRICT - OREGON

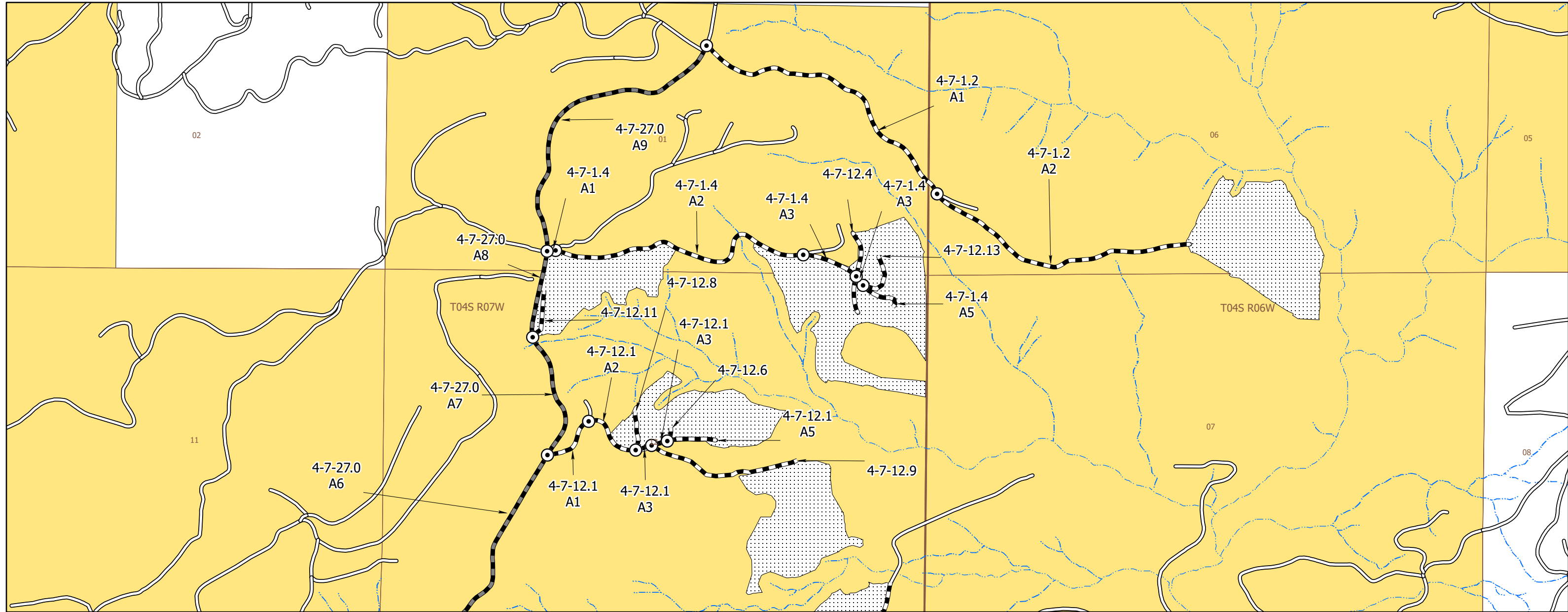

- BLM controlled road - BLM Maintenance - Designated Haul Route
- BLM controlled road - Purchaser Maintenance - Designated Haul Route
- Existing Roads
- Coastal Chrome Project Area
- Streams
- Bureau of Land Management
- Private

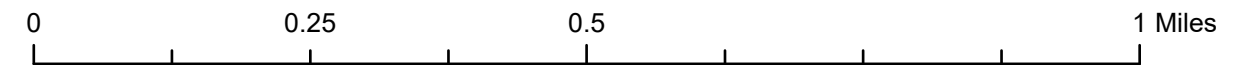

No warranty is made by the Bureau of Land Management as to the accuracy, reliability, or completeness of these data for individual or aggregate use with other data. Original data were compiled from various sources and may be updated without notification.
Prepared By: Austin Bettis

**United States Department of Interior
BUREAU OF LAND MANAGEMENT
NORTHWEST OREGON DISTRICT - OREGON
Road Plan Map**

Coastal Chrome Timber Sale
Contract NO ORN04-TS-2023-0402
Exhibit E
Page 2 of 9

T. 04S. R. 07W. Sections 1, 12, 13, 14, 15, 23, & 24 W.M. - NORTHWEST OREGON DISTRICT - OREGON
T. 04S. R. 06W Sections 6, 7, & 18 W.M. - NORTHWEST OREGON DISTRICT - OREGON
T. 05S. R. 07W. Sections 11 & 15 W.M. - NORTHWEST OREGON DISTRICT - OREGON

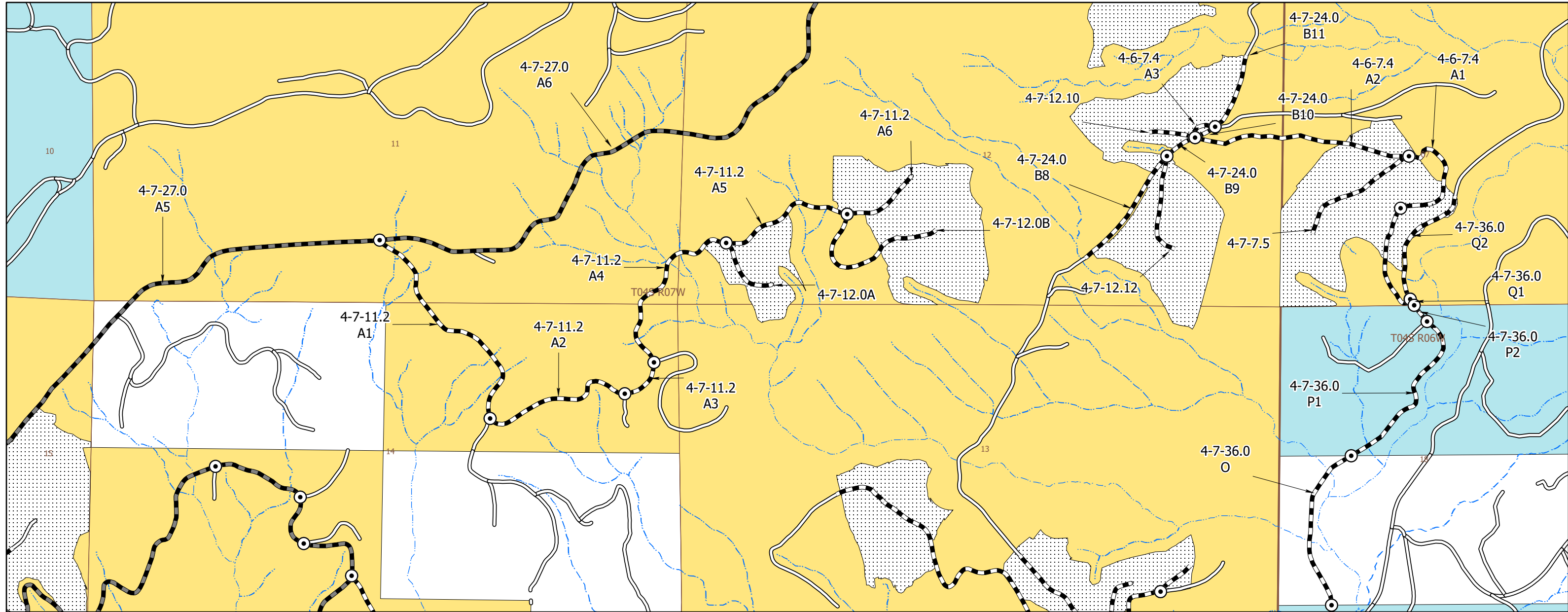

- BLM controlled road - BLM Maintenance - Designated Haul Route
- BLM controlled road - Purchaser Maintenance - Designated Haul Route
- Existing Roads
- Coastal Chrome Project Area
- Streams
- Bureau of Land Management
- State
- Private

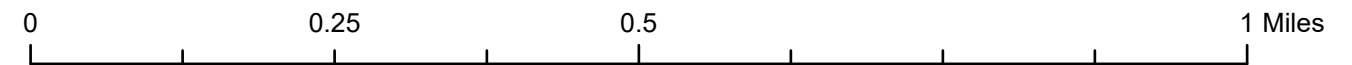







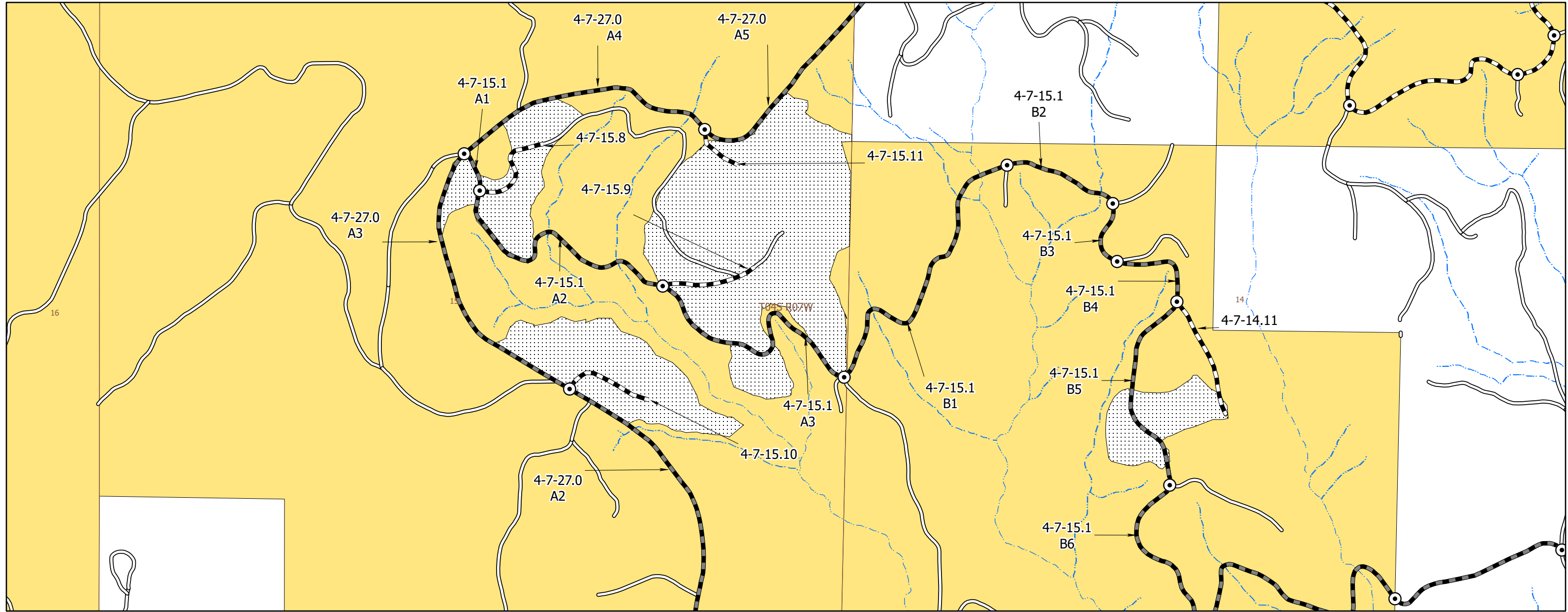

No warranty is made by the Bureau of Land Management as to the accuracy, reliability, or completeness of these data for individual or aggregate use with other data. Original data were compiled from various sources and may be updated without notification.
Prepared By: Austin Bettis

**United States Department of Interior
BUREAU OF LAND MANAGEMENT
NORTHWEST OREGON DISTRICT - OREGON
Road Plan Map**

Coastal Chrome Timber Sale
Contract NO ORN04-TS-2023-0402
Exhibit E
Page 3 of 9

T. 04S. R. 07W. Sections 1, 12, 13, 14, 15, 23, & 24 W.M. - NORTHWEST OREGON DISTRICT - OREGON
T. 04S. R. 06W Sections 6, 7, & 18 W.M. - NORTHWEST OREGON DISTRICT - OREGON
T. 05S. R. 07W. Sections 11 & 15 W.M. - NORTHWEST OREGON DISTRICT - OREGON



-  BLM controlled road - BLM Maintenance - Designated Haul Route
-  BLM controlled road - Purchaser Maintenance - Designated Haul Route
-  Existing Roads
-  Coastal Chrome Project Area
-  Streams
-  Bureau of Land Management
-  Private

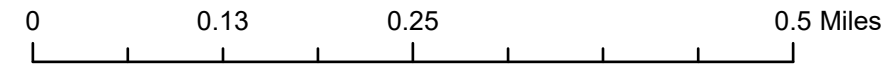

No warranty is made by the Bureau of Land Management as to the accuracy, reliability, or completeness of these data for individual or aggregate use with other data. Original data were compiled from various sources and may be updated without notification.
Prepared By: Austin Bettis

**United States Department of Interior
BUREAU OF LAND MANAGEMENT
NORTHWEST OREGON DISTRICT - OREGON
Road Plan Map**

T. 04S. R. 07W. Sections 1, 12, 13, 14, 15, 23, & 24 W.M. - NORTHWEST OREGON DISTRICT - OREGON
T. 04S. R. 06W Sections 6, 7, & 18 W.M. - NORTHWEST OREGON DISTRICT - OREGON
T. 05S. R. 07W. Sections 11 & 15 W.M. - NORTHWEST OREGON DISTRICT - OREGON

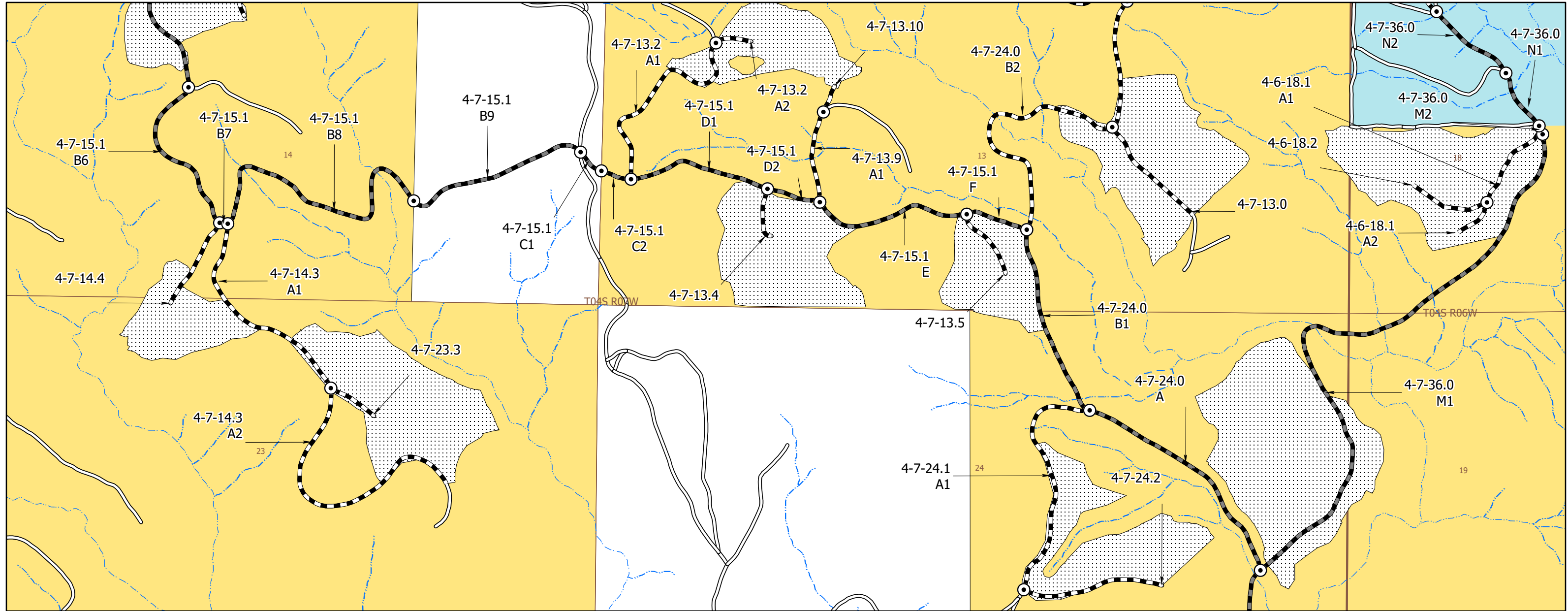

- BLM controlled road - BLM Maintenance - Designated Haul Route
- BLM controlled road - Purchaser Maintenance - Designated Haul Route
- Existing Roads
- Coastal Chrome Project Area
- Streams
- Bureau of Land Management
- State
- Private

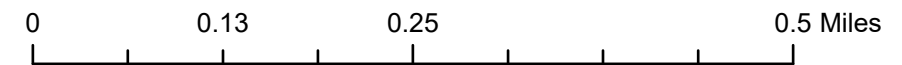







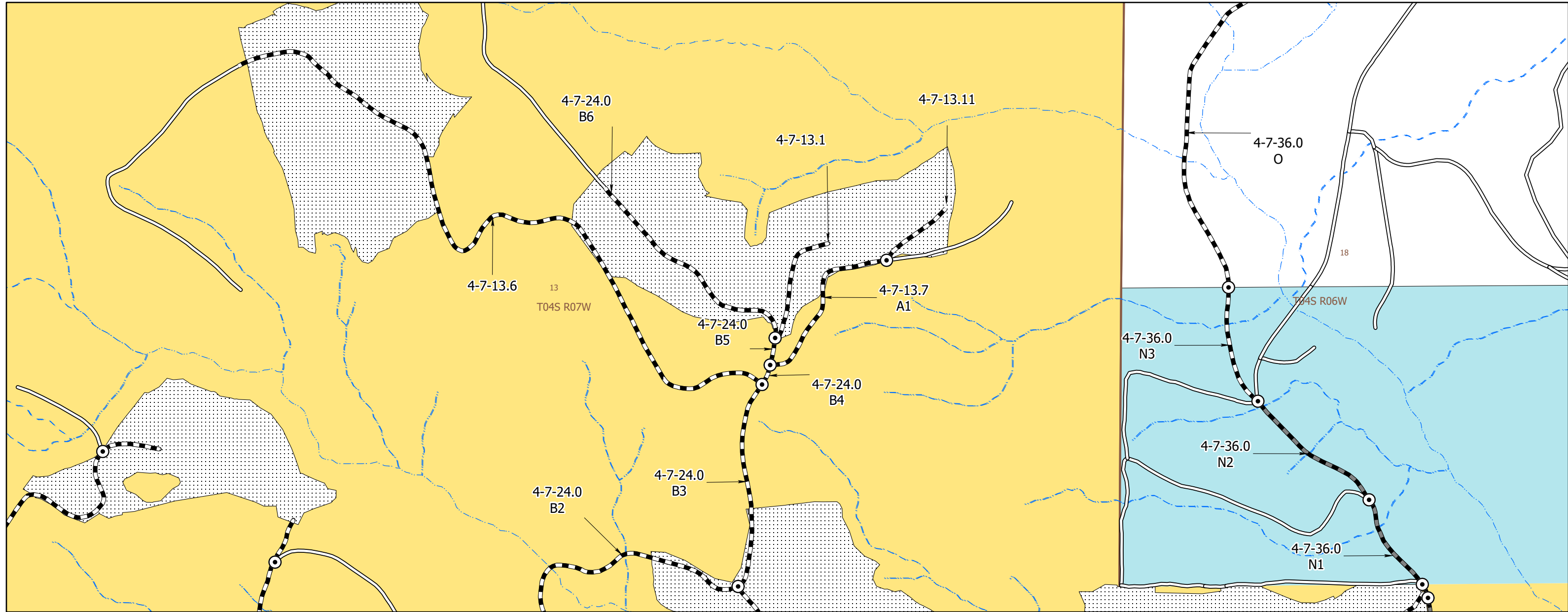

No warranty is made by the Bureau of Land Management as to the accuracy, reliability, or completeness of these data for individual or aggregate use with other data. Original data were compiled from various sources and may be updated without notification.
Prepared By: Austin Bettis

**United States Department of Interior
BUREAU OF LAND MANAGEMENT
NORTHWEST OREGON DISTRICT - OREGON
Road Plan Map**

T. 04S. R. 07W. Sections 1, 12, 13, 14, 15, 23, & 24 W.M. - NORTHWEST OREGON DISTRICT - OREGON
T. 04S. R. 06W Sections 6, 7, & 18 W.M. - NORTHWEST OREGON DISTRICT - OREGON
T. 05S. R. 07W. Sections 11 & 15 W.M. - NORTHWEST OREGON DISTRICT - OREGON



-  BLM controlled road - BLM Maintenance - Designated Haul Route
-  BLM controlled road - Purchaser Maintenance - Designated Haul Route
-  Existing Roads
-  Coastal Chrome Project Area
-  Streams
-  Bureau of Land Management
-  State
-  Private

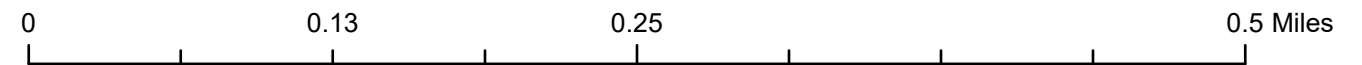

No warranty is made by the Bureau of Land Management as to the accuracy, reliability, or completeness of these data for individual or aggregate use with other data. Original data were compiled from various sources and may be updated without notification.
Prepared By: Austin Bettis

**United States Department of Interior
BUREAU OF LAND MANAGEMENT
NORTHWEST OREGON DISTRICT - OREGON**

Road Plan Map

T. 04S. R. 07W. Sections 1, 12, 13, 14, 15, 23, & 24 W.M. - NORTHWEST OREGON DISTRICT - OREGON

T. 04S. R. 06W Sections 6, 7, & 18 W.M. - NORTHWEST OREGON DISTRICT - OREGON

T. 05S. R. 07W. Sections 11 & 15 W.M. - NORTHWEST OREGON DISTRICT - OREGON

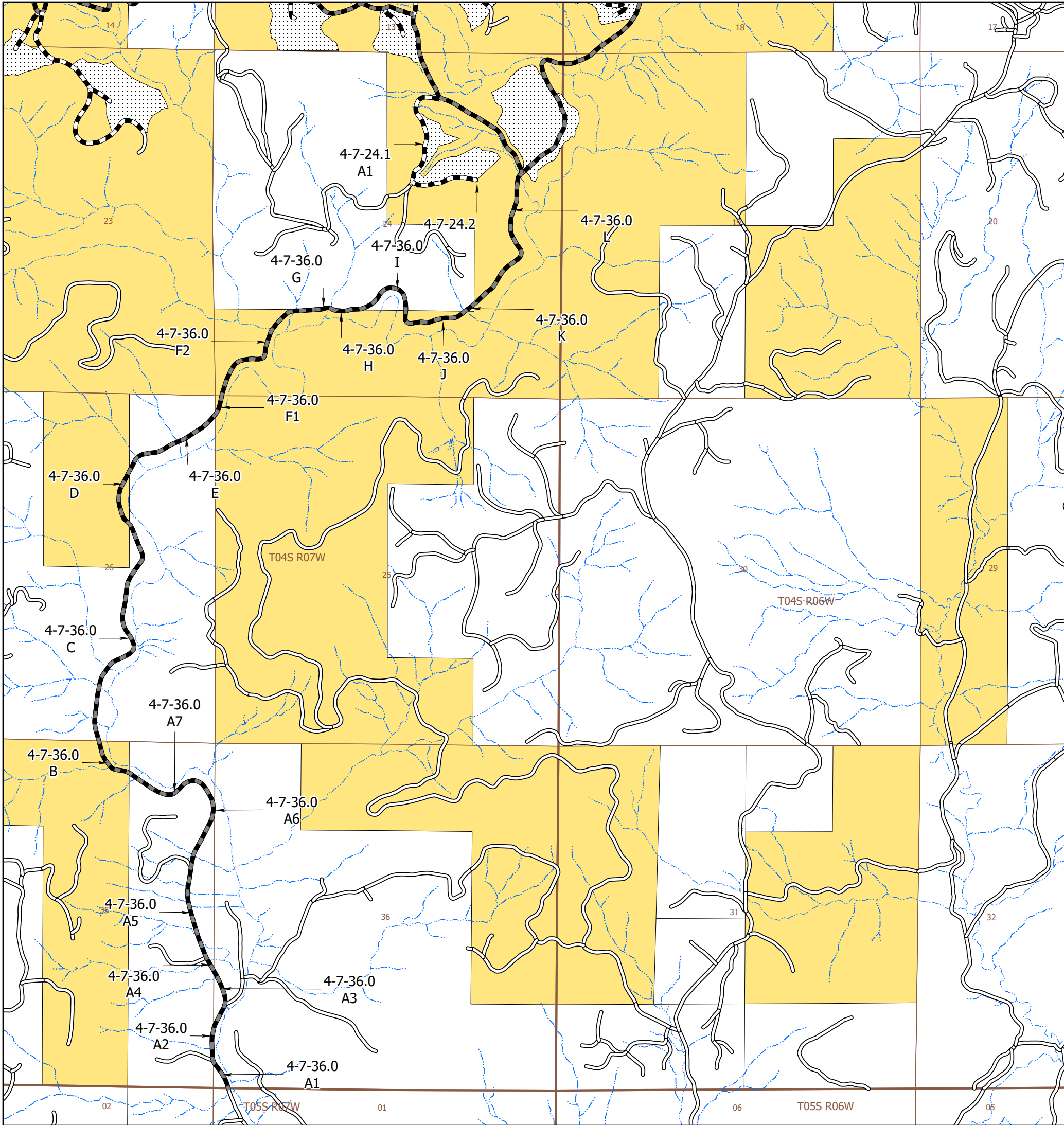

- BLM controlled road - BLM Maintenance - Designated Haul Route
- BLM controlled road - Purchaser Maintenance - Designated Haul Route
- Existing Roads
- Coastal Chrome Project Area
- Streams
- Bureau of Land Management
- State
- Private

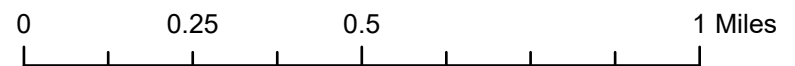

No warranty is made by the Bureau of Land Management as to the accuracy, reliability, or completeness of these data for individual or aggregate use with other data. Original data were compiled from various sources and may be updated without notification.
Prepared By: Austin Bettis

**United States Department of Interior
BUREAU OF LAND MANAGEMENT
NORTHWEST OREGON DISTRICT - OREGON**

Road Plan Map

T. 04S. R. 07W. Sections 1, 12, 13, 14, 15, 23, & 24 W.M. - NORTHWEST OREGON DISTRICT - OREGON

T. 04S. R. 06W Sections 6, 7, & 18 W.M. - NORTHWEST OREGON DISTRICT - OREGON

T. 05S. R. 07W. Sections 11 & 15 W.M. - NORTHWEST OREGON DISTRICT - OREGON

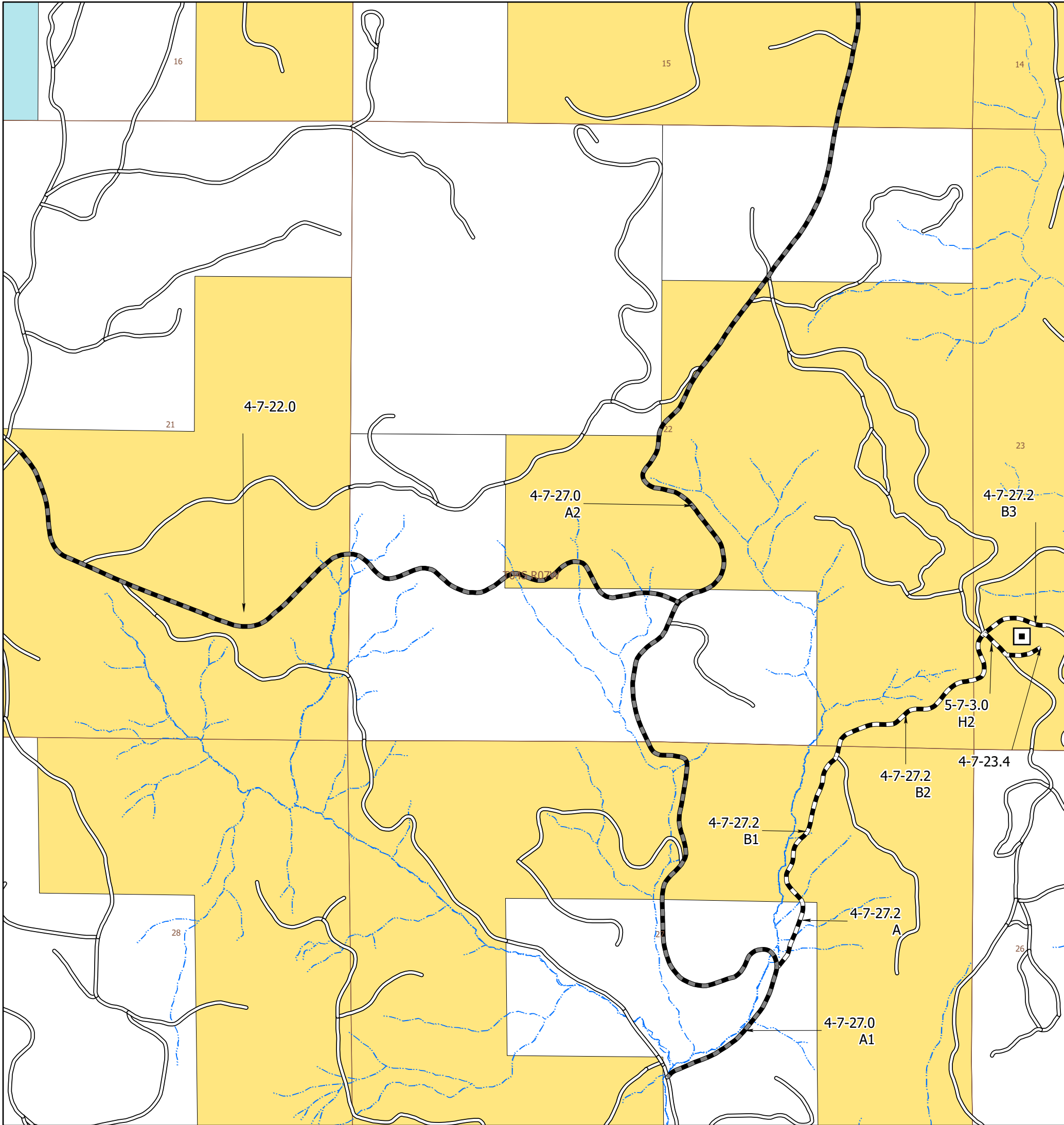

- Whip Up Flats Quarry
- BLM controlled road - BLM Maintenance - Designated Haul Route
- - - BLM controlled road - Purchaser Maintenance - Designated Haul Route
- Existing Roads
- ▨ Coastal Chrome Project Area
- Streams
- Bureau of Land Management
- State
- Private

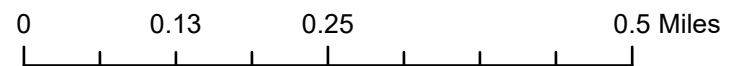

No warranty is made by the Bureau of Land Management as to the accuracy, reliability, or completeness of these data for individual or aggregate use with other data. Original data were compiled from various sources and may be updated without notification.
Prepared By: Austin Bettis

**United States Department of Interior
BUREAU OF LAND MANAGEMENT
NORTHWEST OREGON DISTRICT - OREGON
Road Plan Map**

T. 04S. R. 07W. Sections 1, 12, 13, 14, 15, 23, & 24 W.M. - NORTHWEST OREGON DISTRICT - OREGON
T. 04S. R. 06W Sections 6, 7, & 18 W.M. - NORTHWEST OREGON DISTRICT - OREGON
T. 05S. R. 07W. Sections 11 & 15 W.M. - NORTHWEST OREGON DISTRICT - OREGON

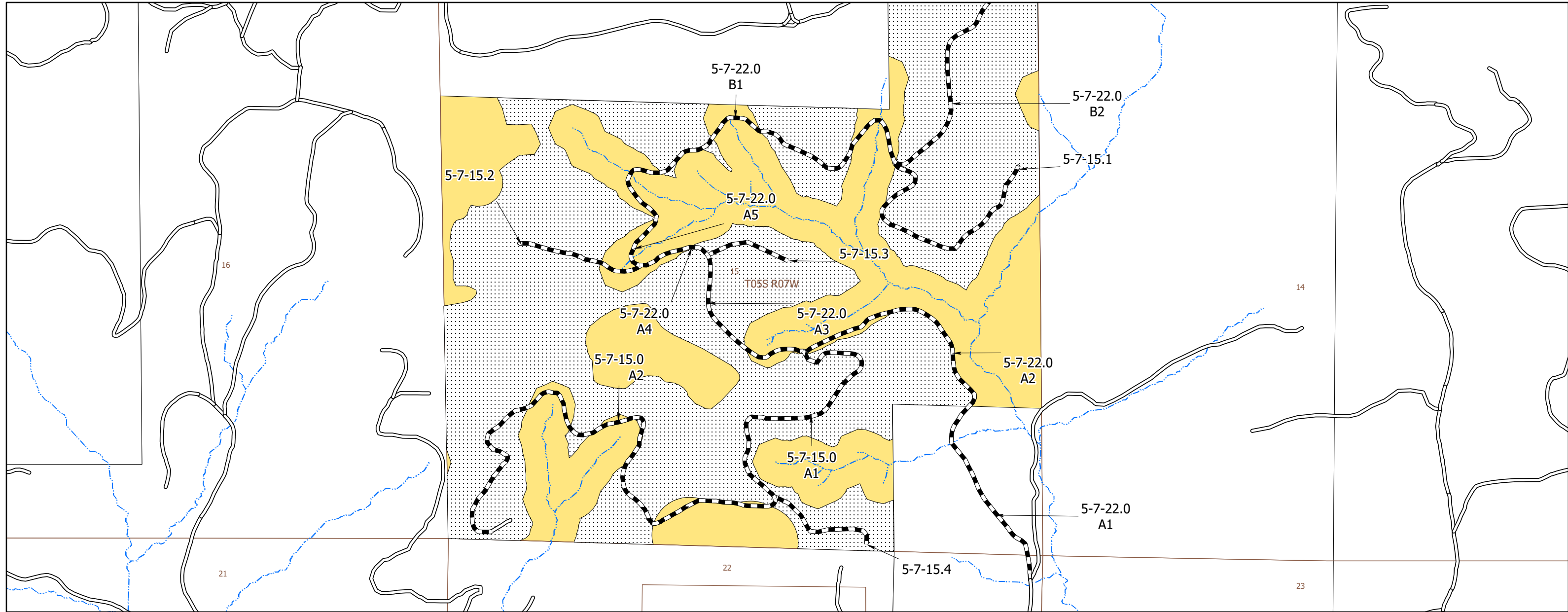

- BLM controlled road - Purchaser Maintenance - Designated Haul Route
- Existing Roads
- Coastal Chrome Project Area
- Streams
- Bureau of Land Management
- Private

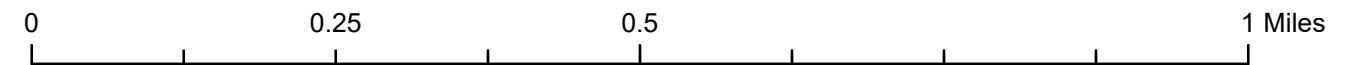

**United States Department of Interior
BUREAU OF LAND MANAGEMENT
NORTHWEST OREGON DISTRICT - OREGON
Road Plan Map**

T. 04S. R. 07W. Sections 1, 12, 13, 14, 15, 23, & 24 W.M. - NORTHWEST OREGON DISTRICT - OREGON
T. 04S. R. 06W Sections 6, 7, & 18 W.M. - NORTHWEST OREGON DISTRICT - OREGON
T. 05S. R. 07W. Sections 11 & 15 W.M. - NORTHWEST OREGON DISTRICT - OREGON

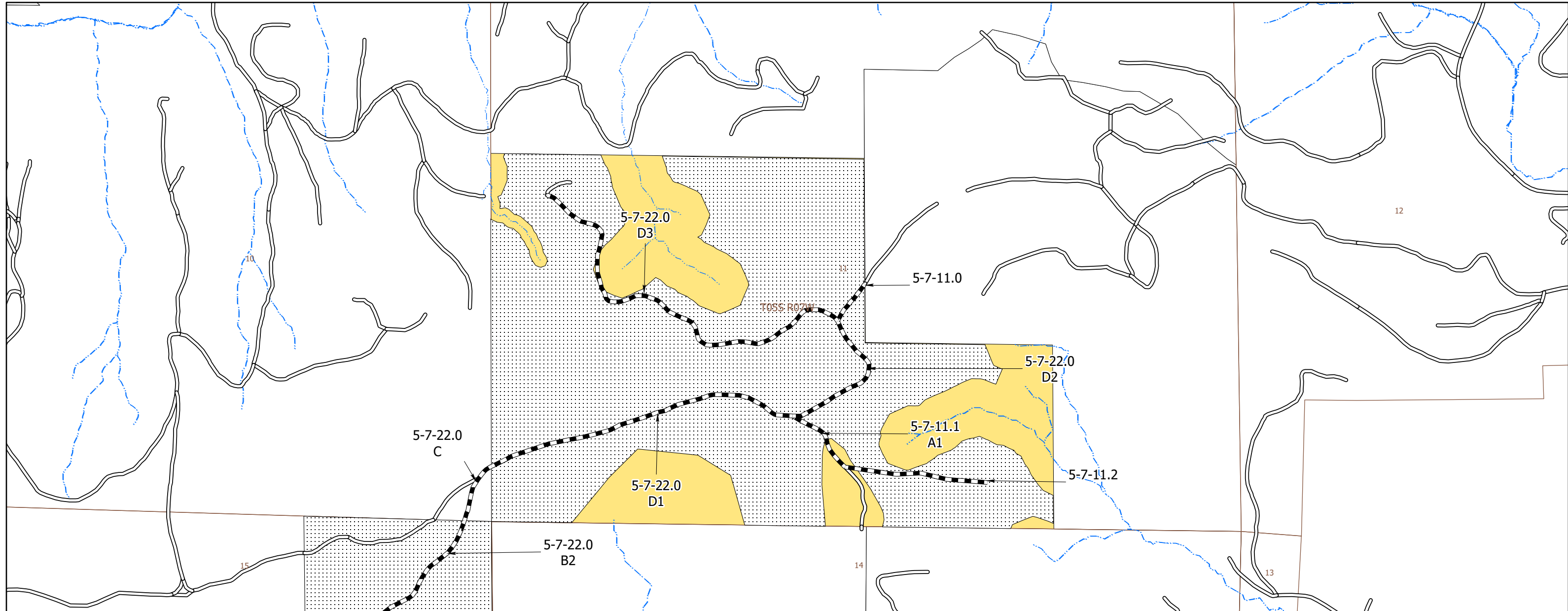

- BLM controlled road - Purchaser Maintenance - Designated Haul Route
- Existing Roads
- Coastal Chrome Project Area
- Streams
- Bureau of Land Management
- Private

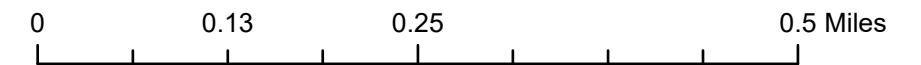

COARSE WOODY DEBRIS (CWD) CREATION

The Purchaser shall select and treat a total of five thousand, two hundred (5,200) reserve trees in the CWD Creation Units shown on Exhibit F maps (pages 7-25) to create Coarse Woody Debris (CWD) by saw-topping, high-girdling, basal-girdling, or felling. Treated trees will be marked with flagging as specified by the Authorized Officer.

The Purchaser must provide a proposed schedule of work to the Authorized Officer at least one week prior to commencing the CWD creation activities.

CWD Creation per CWD Unit

CWD Number	Unit	CWD Acres	Unit	Total Trees	Saw-Top	High Girdle	Basal Girdle	Fell	Tree Size
10A		26		215	35	35	145	0	15-20
10B		10		215	0	0	215	0	15-20
10C		13		50	12	12	26	0	15-20
10D		1		10	0	0	10	0	15-20
10E		27		60	0	0	60	0	15-20
11A		5		50	5	5	40	0	21-30
11B		2		10	2	2	6	0	21-30
11C		3		10	0	0	10	0	21-30
13A		20		120	22	22	76	0	15-20
13B		3		100	0	0	100	0	15-20
13C		3		10	3	3	4	0	15-20
13D		1		5	0	0	5	0	15-20
13E		5		15	0	0	15	0	15-20
14A		5		35	1	1	33	0	15-20
14B		0		15	0	0	15	0	15-20
14C		1		10	5	5	0	0	15-20
14D		4		20	4	4	12	0	15-20
14E		6		20	0	0	20	0	15-20
14F		9		19	0	0	0	19	21-30
15A		13		60	15	15	30	0	15-20
15B		2		90	0	0	90	0	15-20
16A		7		72	12	12	48	0	15-20
16B		1		8	4	4	0	0	15-20
16C		1		5	1	1	3	0	15-20
16D		4		5	0	0	5	0	15-20
17A		10		58	11	11	36	0	15-20
17B		2		84	0	0	84	0	15-20
17C		1		8	4	4	0	0	15-20
17D		4		10	4	4	2	0	15-20
17E		1		10	0	0	10	0	15-20
17F		11		20	0	0	20	0	15-20
17G		7		28	0	0	0	28	21-30
18A		10		79	5	5	69	0	15-20

18B	2	30	0	0	30	0	15-20
18C	2	15	5	5	5	0	15-20
18D	1	6	3	3	0	0	15-20
18E	4	15	4	4	7	0	15-20
18F	0	5	0	0	5	0	15-20
18G	2	20	0	0	20	0	15-20
18H	4	42	0	0	0	42	15-20
19A	12	60	10	10	40	0	15-20
19B	1	50	0	0	50	0	15-20
19C	1	30	0	0	30	0	15-20
19D	2	10	5	5	0	0	15-20
19E	0	10	2	2	6	0	15-20
19F	1	10	0	0	10	0	15-20
1A	15	72	13	13	46	0	15-20
1B	1	50	0	0	50	0	15-20
1C	3	88	0	0	88	0	15-20
1D	4	20	10	10	0	0	15-20
1E	3	5	3	2	0	0	15-20
1F	1	10	0	1	9	0	15-20
1G	8	15	0	0	15	0	15-20
20A	5	50	1	1	48	0	15-20
20B	2	10	5	5	0	0	15-20
20C	7	35	7	7	21	0	15-20
20D	16	35	0	0	35	0	15-20
21A	20	160	26	26	108	0	15-20
21B	3	100	0	0	100	0	15-20
21C	3	15	3	3	9	0	15-20
21D	6	15	0	0	15	0	15-20
22A	12	80	20	20	40	0	15-20
22B	1	30	0	0	30	0	15-20
22C	1	40	0	0	40	0	15-20
22D	2	50	0	0	50	0	15-20
23A	21	180	25	25	130	0	15-20
23B	3	110	0	0	110	0	15-20
23C	2	10	5	5	0	0	15-20
23D	3	15	3	3	9	0	15-20
23E	1	15	0	0	15	0	15-20
24A	15	90	18	18	54	0	15-20
24B	2	90	0	0	90	0	15-20
24C	0	10	2	2	6	0	15-20
24D	3	10	0	0	10	0	15-20
25A	9	60	15	15	30	0	15-20
25B	2	90	0	0	90	0	15-20
25C	3	10	2	2	6	0	15-20
25D	5	10	0	0	10	0	15-20
26A	5	5	3	2	0	0	21-30
26B	9	9	5	4	0	0	16-24

26C	98	17	8	9	0	0	15-20
		20	10	10	0	0	16-24
		61	30	31	0	0	21-39
26D	25	25	12	13	0	0	16-24
26E	5	50	13	12	25	0	16-24
27	73	71	42	29	0	0	16-24
28	13	12	8	4	0	0	16-24
29	204	201	101	100	0	0	16-24
2A	8	36	9	9	18	0	15-20
2B	2	54	0	0	54	0	15-20
2C	3	10	5	5	0	0	15-20
2D	3	15	0	0	15	0	15-20
2E	10	25	0	0	25	0	15-20
3A	23	100	26	26	48	0	15-20
3B	4	160	0	0	160	0	15-20
3C	5	25	5	5	15	0	15-20
3D	11	25	0	0	25	0	15-20
4A	8	65	11	11	43	0	15-20
4B	1	45	0	0	45	0	15-20
4C	5	20	5	5	0	0	15-20
4D	0	5	0	0	15	0	15-20
4E	10	25	0	0	25	0	15-20
5A	14	88	17	17	54	0	15-20
5B	2	82	0	0	82	0	15-20
5C	2	6	3	3	0	0	15-20
5D	1	9	0	0	9	0	15-20
5E	6	15	0	0	15	0	15-20
6A	5	20	5	5	10	0	15-20
6B	0	30	0	0	30	0	15-20
6C	3	17	4	4	9	0	15-20
6D	0	3	0	0	3	0	15-20
6E	10	20	0	0	20	0	15-20
7A	21	145	24	24	97	0	15-20
7B	3	95	0	0	95	0	15-20
7C	4	8	4	4	0	0	15-20
7D	1	12	0	0	12	0	15-20
7E	2	20	0	0	20	0	15-20
8A	9	90	9	9	72	0	21-30
8B	3	50	5	5	40	0	15-20
Total	1235	5200	696	678	3737	89	

¹ See Coarse Woody Debris Creation maps (Exhibit F pages 7-25)

1. **Tree Selection** – The Purchaser shall select five thousand two hundred (5,200) reserve trees to create CWD by saw-topping, high-girdling basal-girdling, or felling according to the following guidelines. Numbers of trees and tree sizes to be selected, specific to each CWD unit, are displayed

in the table above. Placement of trees to be selected by treatment type within the individual treatment units is displayed on the Coarse Woody Debris Creation maps (Exhibit F pages 7-25). The locations of the selected trees (individually or in small groups; distance from roads or property line) varies by treatment method; see treatment methods below for additional treatment-specific information concerning tree selection. There are two units where BLM has pre-selected most of the trees to be treated. Pre-selected trees will be shown on Exhibit F maps and a GPS layer will be provided to aid in locating these trees.

- Only healthy Douglas-fir trees shall be selected for treatment.
 - No trees marked with any existing metal tags shall be selected for treatment.
 - No trees with limbs > 4” in diameter.
 - No trees with nests or any nest-like structures of any birds or mammals, or trees with defects such as cavities, platforms, mistletoe infection, or dead, forked/multiple and/or broken tops shall be selected.
 - Selected trees shall be evenly distributed throughout the CWD units. When selecting trees, select approximately fifty (50) percent of the trees larger than the median tree size for the given range, and approximately fifty (50) percent of the trees smaller than the median tree size for the given range unless stand conditions dictate otherwise. If only trees smaller than the appropriate size are available, select trees of the largest size class present. Do not select the largest, most dominant tree within any given area.
- a. **Saw-topping and High-girdling:** Select healthy appearing Douglas-fir trees with live crown ratios greater than thirty (30) percent and with **average or larger** crown spread. If only trees with smaller live crown ratios than appropriate are available, select trees with the largest crown ratio present. Treatment types and selected trees shall be scattered uniformly throughout the units. Trees selected for saw-topping shall be selected singly or in small groups of three (3) to five (5) trees. Trees selected for high girdling shall be selected in groups of three (3) to five (5) trees. Trees selected for saw-topping or high-girdling shall not be located within falling distance of a drivable road (open after use) or property line boundary where BLM land abuts non-federal ownership.
 - b. **Basal-girdling:** Select healthy Douglas-fir trees with live crown ratios **less** than thirty (30) percent and **smaller** than average crown spread. If only trees with larger live crown ratios than appropriate are available, select appropriately sized trees with the smallest crown ratio present. Selected trees shall be located within the portion of the CWD units designated for basal-girdling and selected in groups of three (3) to five (5) trees. Trees selected for basal girdling shall not be located within falling distance of a drivable road (open after use) or a property line boundary where BLM land abuts non-federal.
 - c. **Tree felling:** Select Douglas-fir trees with live crown ratios less than thirty (30) percent and smaller than average crown spread. If only trees with larger live crown ratios than appropriate are available, select appropriately sized trees with the smallest crown ratio present. Selected

trees shall be located within the portion of the CWD unit designated for felling and shall be scattered uniformly throughout the unit. Trees selected for felling shall be and selected singly (not in groups). The portion of the tree in contact with the stream channel would be at least six (6) inches in diameter. Trees selected for felling shall be those trees which provide minimal amounts or no shade to streams (e.g., north side of stream channel and/or being an area where topography or tree location minimizes the shade afforded to stream by selected tree, such as being located several tree spacings from the stream channel).

2. **Timing Restrictions**

- a. Chainsaw use within the Restricted Operating Area shown on Exhibit F Maps shall not be permitted from April 1 through August 5 of each year, both days inclusive; and shall not begin until 2 hours after sunrise and shall cease 2 hours prior to sunset from August 6 through September 15 of each year, both days inclusive. These restrictions shall not be waived.

2. **CWD Treatments**

- a. **Saw-Topping** – severing the treetop within the live crown.
 1. The Purchaser shall climb and top selected trees at a height of at least sixty (60) feet above the ground at a point where approximately twenty to fifty (20-50) percent of the live crown remains; saw-topping heights shall be varied equally within this placement within the live crown. Topping shall be done with power tools (e.g., chainsaws).
 2. To the extent practicable, the Purchaser shall retain all green limbs and the largest dead limbs on the treated trees during the climbing and topping operations.
 3. Tree tops shall be completely severed from the tree and fall completely to the ground inside unit boundaries.
 4. To the extent practicable, the Purchaser shall directionally fall tops to not damage existing snags, under-story conifers, any tree containing a suspected nest of a bird or mammal, or any tree with defects such as hollow cavities, multiple tops, or decay, and avoid contact with unburned burn piles and drivable roads.
 5. The Contractor shall tie two pieces of flagging of a color approved by the Authorized Officer on a branch, or around the bole, directly below the saw top. Flagging shall extend a minimum of three feet downward and must be visible from the ground.
- b. **High-Girdling** – girdling within the live crown.
 1. The Purchaser shall climb, and girdle selected trees within the live crown at a point where approximately twenty to fifty (20-50) percent of the live crown remains below the point of girdling and at a height of at least sixty (60) feet above the ground; girdling heights shall be varied equally within this placement within the live crown. Girdling may be done with a hand tool or power tool and will consist of removing all bark and cambium in a ten to twelve (10-12) inch band completely around the main stem of the tree.

2. Tool cuts must not penetrate more than one-half (0.5) inches into the wood of high-girdled trees.
3. Live limbs below the point of high girdling shall not be removed. To the extent practicable, the Purchaser shall retain the largest dead limbs on the trees during the climbing and high-girdling operations.
4. The Contractor shall tie two pieces of flagging of a color approved by the Authorized Officer on a branch, or around the bole, directly below the girdle site. Flagging shall extend a minimum of three feet downward and must be visible from the ground.

c. Basal-Girdling

1. When logging machinery, such as harvesters, are used to basal-girdle trees, tree shall have the bark and cambium layer removed from a 12-inch wide or greater band completely encircling the bole of the tree at or below breast height as directed by the Authorized Officer. No flagging is required.
2. When chainsaws are used to basal-girdle trees, girdling will be accomplished by making two (2) parallel cuts around the tree. Each cut must connect with itself completely around the tree and penetrate through the cambium layer into the wood at least ½ inch, but not more than 1 inch. The distance between the top cut and the bottom cut shall not exceed twelve (12) inches. Trees shall be girdled between 3 and 4 feet above ground level measured on the uphill side of the tree. The Contractor shall tie one piece of flagging of a color approved by the Authorized Officer around the bole of each treated tree near DBH level.

3. Documentation

1. The Purchaser shall provide the location for all saw-topped, high-girdled, basal-girdled or felled trees by collecting GPS points. If acceptable GPS satellite coverage cannot be obtained at a site, the point shall be hand drawn onto a map and submitted to the Authorized Officer.
2. The Purchaser shall tally all CWD trees by 2-inch diameter class, tree species, snag type, and unit identifier daily. The Authorized Officer may request the tally at any time during CWD operations. At the completion of operations, the Purchaser shall submit a completed tally to the Authorized Officer.
3. All information recorded on the tally sheet shall be legible, clear, and reproducible on a black and white copy machine. The Purchaser shall review all documents to ensure completeness, legibility, accuracy, and consistency in style before submitting them to the Authorized Officer.



United States Department of the Interior
 BUREAU OF LAND MANAGEMENT
 TIMBER SALE CONTRACT MAP

Contract No. ORN04-TS-2023.0402
 Coastal Chrome Timber Sale
 Exhibit F
 Page 7 of 25

5/31/2023

T. 5S. R. 7W, Section 15 W. M. - NORTHWEST OREGON DISTRICT - OREGON

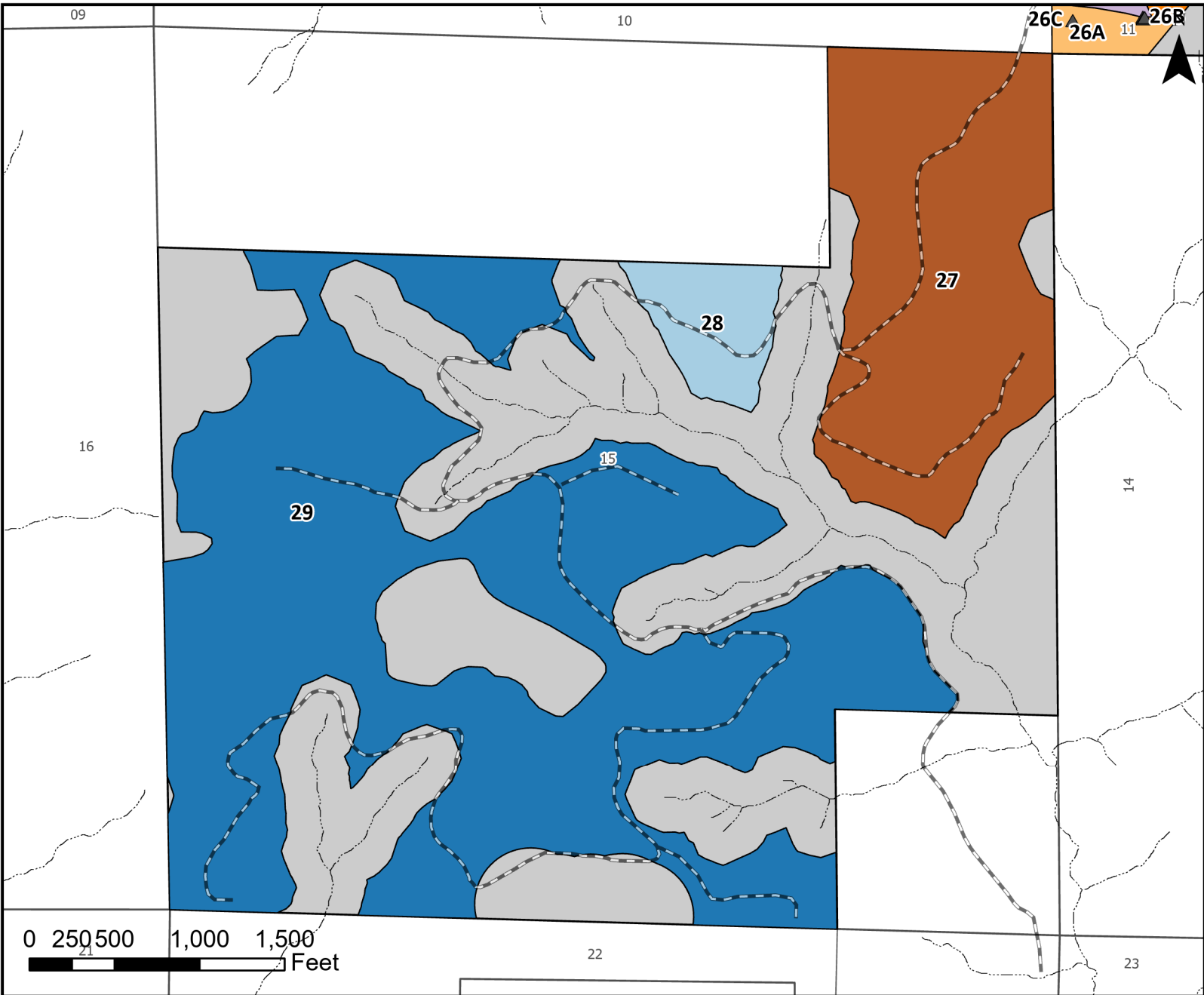

- ▲ Pre-selected Snags
- Streams
- Project Roads
- Contract Area
- 26A
- 26B
- 26C
- 27
- 28
- 29

CWD Unit Number	CWD Unit Acres	Total Trees	Saw-top	High Girdle	Basal Girdle	Fell	Tree Size to be Selected (in. at DBH)
26A	5	5	3	2	0	0	21-30
27	73	71	42	29	0	0	16-24
28	13	12	8	4	0	0	16-24
29	204	201	101	100	0	0	16-24

No warranty is made by the Bureau of Land Management as to the accuracy, reliability, or completeness of these data for individual or aggregate use with other data. Original data were compiled from various sources and may be updated without notification. Note: Boundaries of harvest areas are painted/flagged in orange and posted. Right-of-ways (ROW) are posted. Harvest area acres do not include existing roads. Prepared By: dtyler



United States Department of the Interior
 BUREAU OF LAND MANAGEMENT
 TIMBER SALE CONTRACT MAP

Contract No. ORN04-TS-2023.0402
 Coastal Chrome Timber Sale
 Exhibit F
 Page 8 of 25

5/31/2023

T. 5S. R. 7W, Section 11 W. M. - NORTHWEST OREGON DISTRICT - OREGON

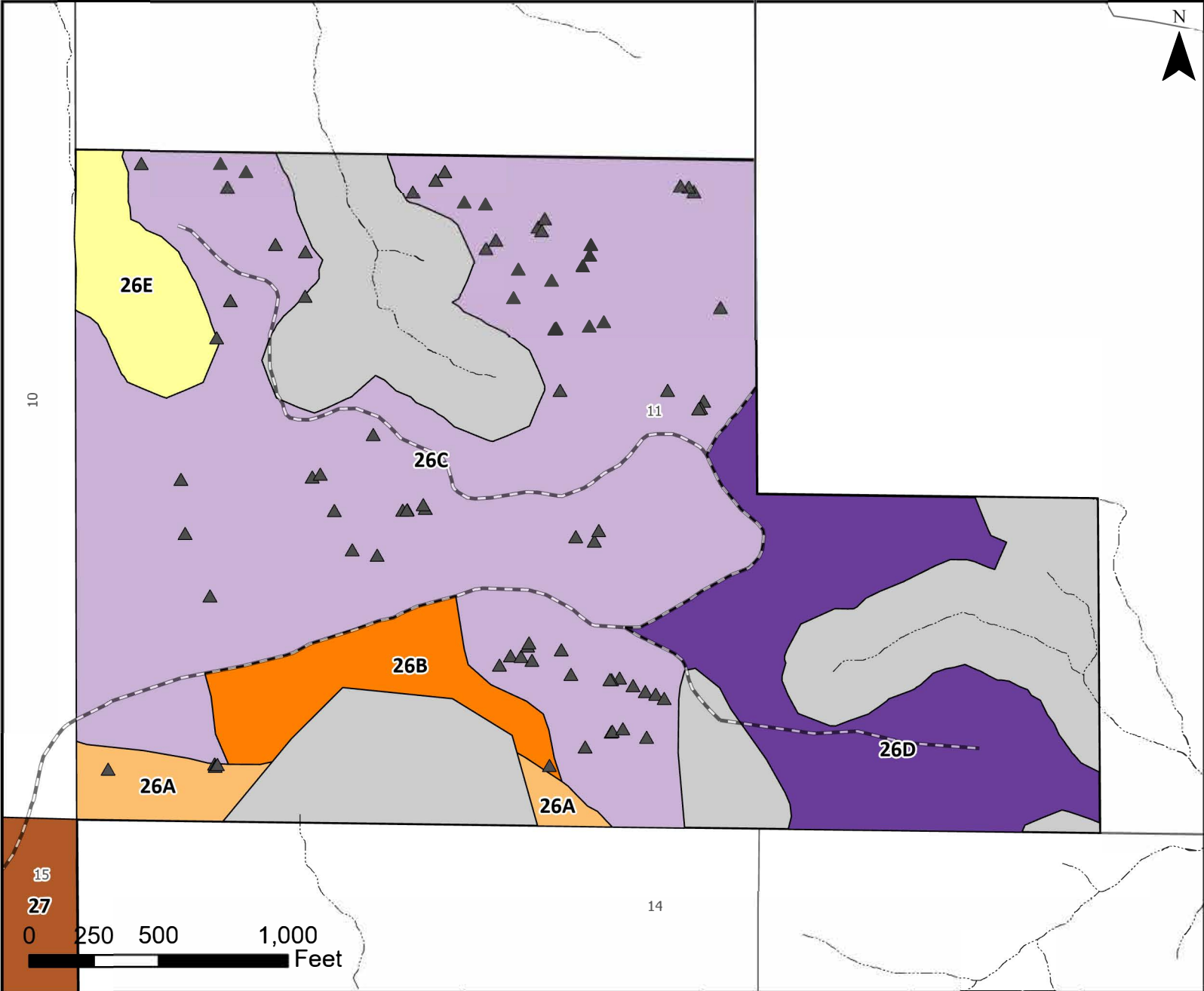

- ▲ Pre-selected Snags
- Streams
- Project Roads
- Contract Area
- 26A
- 26B
- 26C
- 26D
- 26E
- 27

CWD Unit Number	CWD Unit Acres	Total Trees	Saw-top	High Girdle	Basal Girdle	Fell	Tree Size to be Selected (in. at DBH)
26A	5	5	3	2	0	0	21-30
26B	9	9	5	4	0	0	16-24
26C	101	17	8	9	0	0	15-20
		20	10	10	0	0	16-24
		61	30	31	0	0	21-39
26D	27	25	12	13	0	0	16-24
26E	7	50	13	12	25	0	16-24
27	73	71	42	29	0	0	16-24

No warranty is made by the Bureau of Land Management as to the accuracy, reliability, or completeness of these data for individual or aggregate use with other data. Original data were compiled from various sources and may be updated without notification. Note: Boundaries of harvest areas are painted/flagged in orange and posted. Right-of-ways (ROW) are posted. Harvest area acres do not include existing roads. Prepared By: dtyler



United States Department of the Interior
BUREAU OF LAND MANAGEMENT
TIMBER SALE CONTRACT MAP

Contract No. ORN04-TS-2023.0402
Coastal Chrome Timber Sale
Exhibit F
Page 9 of 25

5/31/2023

T. 4S. R. 7W, Section 15 W. M. - NORTHWEST OREGON DISTRICT - OREGON

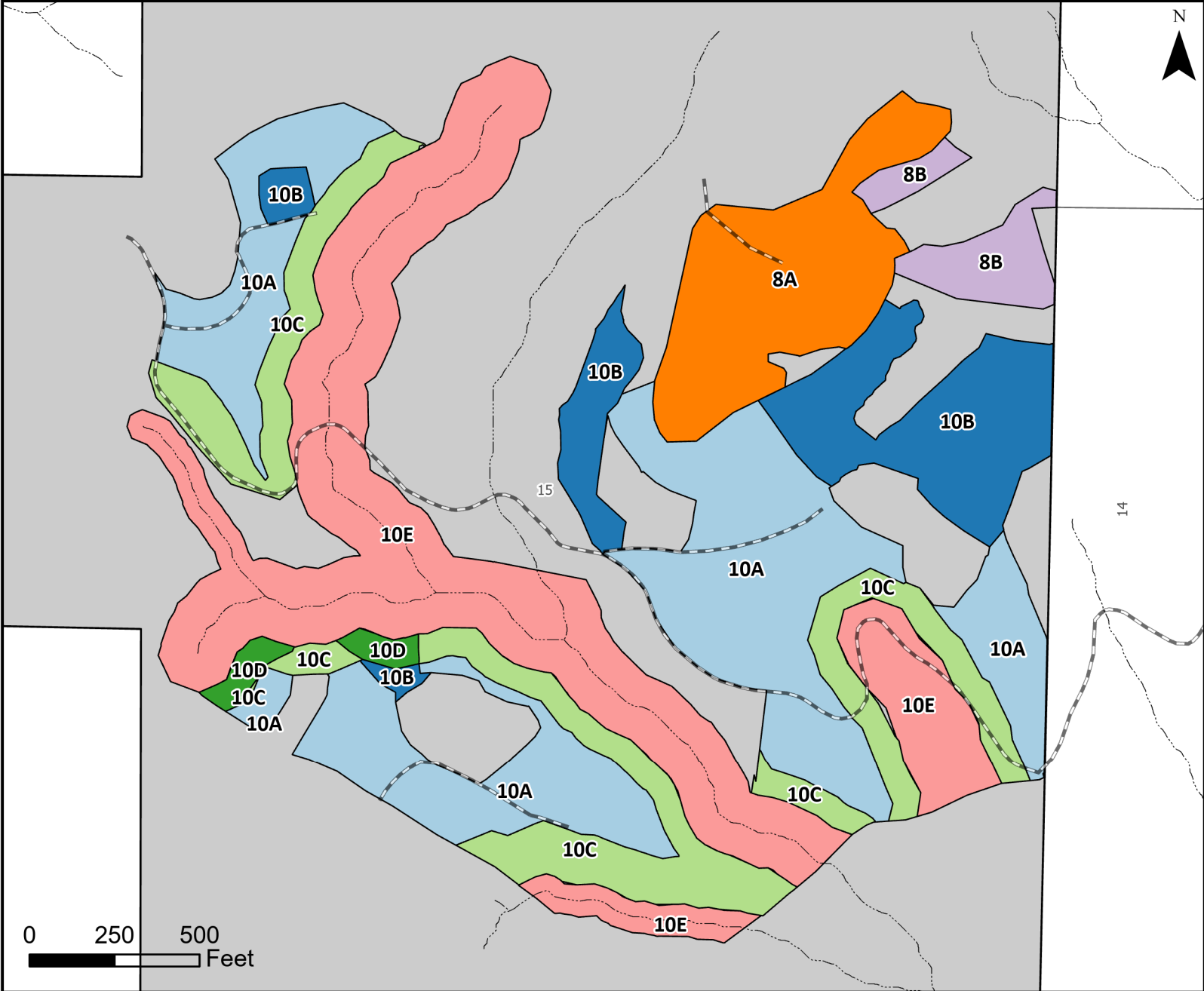

CWD Unit Number	CWD Unit Acres	Total Trees	Saw-top	High Girdle	Basal Girdle	Fell	Tree Size to be Selected (in. at DBH)
10A	26	215	35	35	145	0	15-20
10B	10	215	0	0	215	0	15-20
10C	13	50	12	12	26	0	15-20
10D	1	10	0	0	10	0	15-20
10E	27	60	0	0	60	0	15-20
8A	9	90	9	9	72	0	21-30
8B	3	50	5	5	40	0	15-20

No warranty is made by the Bureau of Land Management as to the accuracy, reliability, or completeness of these data for individual or aggregate use with other data. Original data were compiled from various sources and may be updated without notification. Note: Boundaries of harvest areas are painted/flagged in orange and posted. Right-of-ways (ROW) are posted. Harvest area acres do not include existing roads. Prepared By: dtyler



United States Department of the Interior
 BUREAU OF LAND MANAGEMENT
 TIMBER SALE CONTRACT MAP

Contract No. ORN04-TS-2023.0402
 Coastal Chrome Timber Sale
 Exhibit F
 Page 10 of 25

5/31/2023

T. 4S. R. 7W, Section 14 W. M. - NORTHWEST OREGON DISTRICT - OREGON

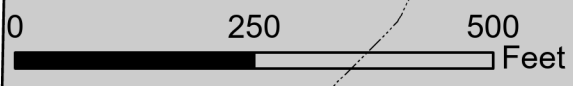
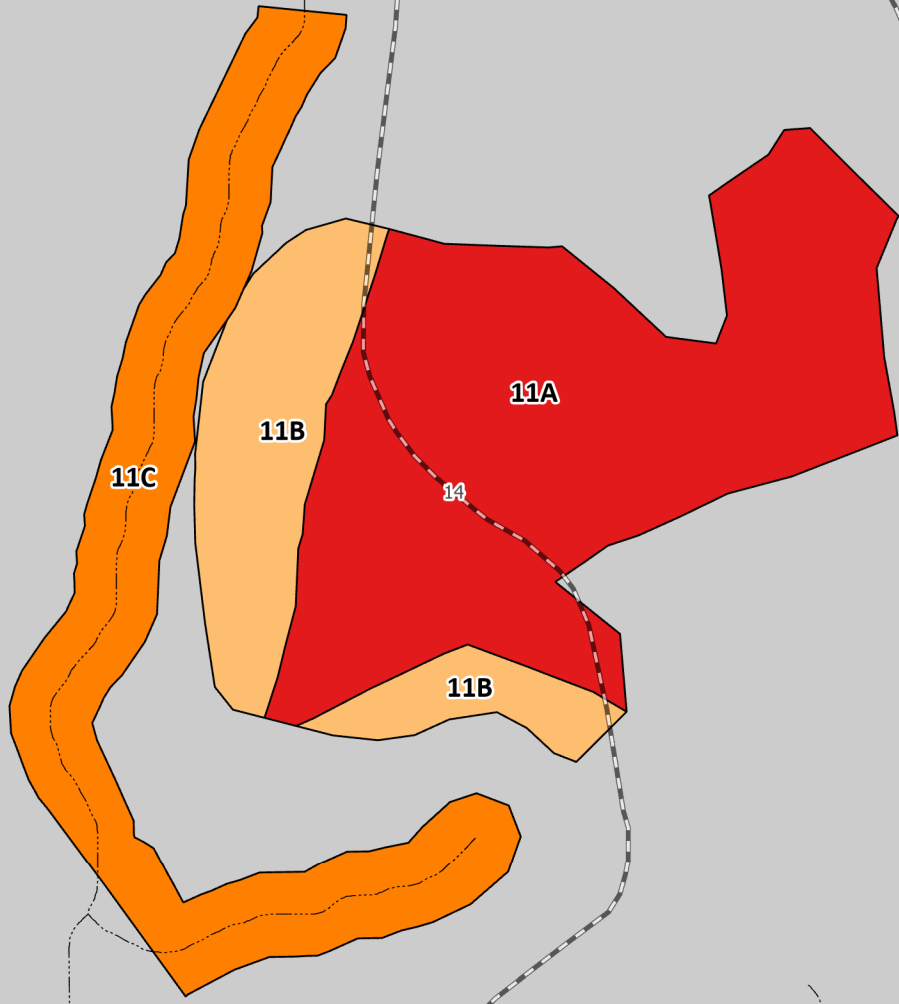

- Streams
- Project Roads
- Contract Area
- 11A
- 11B
- 11C

CWD Unit Number	CWD Unit Acres	Total Trees	Saw-top	High Girdle	Basal Girdle	Fell	Tree Size to be Selected (in. at DBH)
11A	5	50	5	5	40	0	21-30
11B	2	10	2	2	6	0	21-30
11C	3	10	0	0	10	0	21-30

No warranty is made by the Bureau of Land Management as to the accuracy, reliability, or completeness of these data for individual or aggregate use with other data. Original data were compiled from various sources and may be updated without notification. Note: Boundaries of harvest areas are painted/flagged in orange and posted. Right-of-ways (ROW) are posted. Harvest area acres do not include existing roads. Prepared By: dtyler



United States Department of the Interior
 BUREAU OF LAND MANAGEMENT
 TIMBER SALE CONTRACT MAP

Contract No. ORN04-TS-2023.0402
 Coastal Chrome Timber Sale
 Exhibit F
 Page 11 of 25

5/31/2023

T. 4S. R. 7W, Sections 14 & 23 W. M. - NORTHWEST OREGON DISTRICT - OREGON

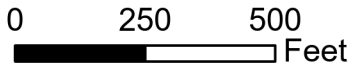
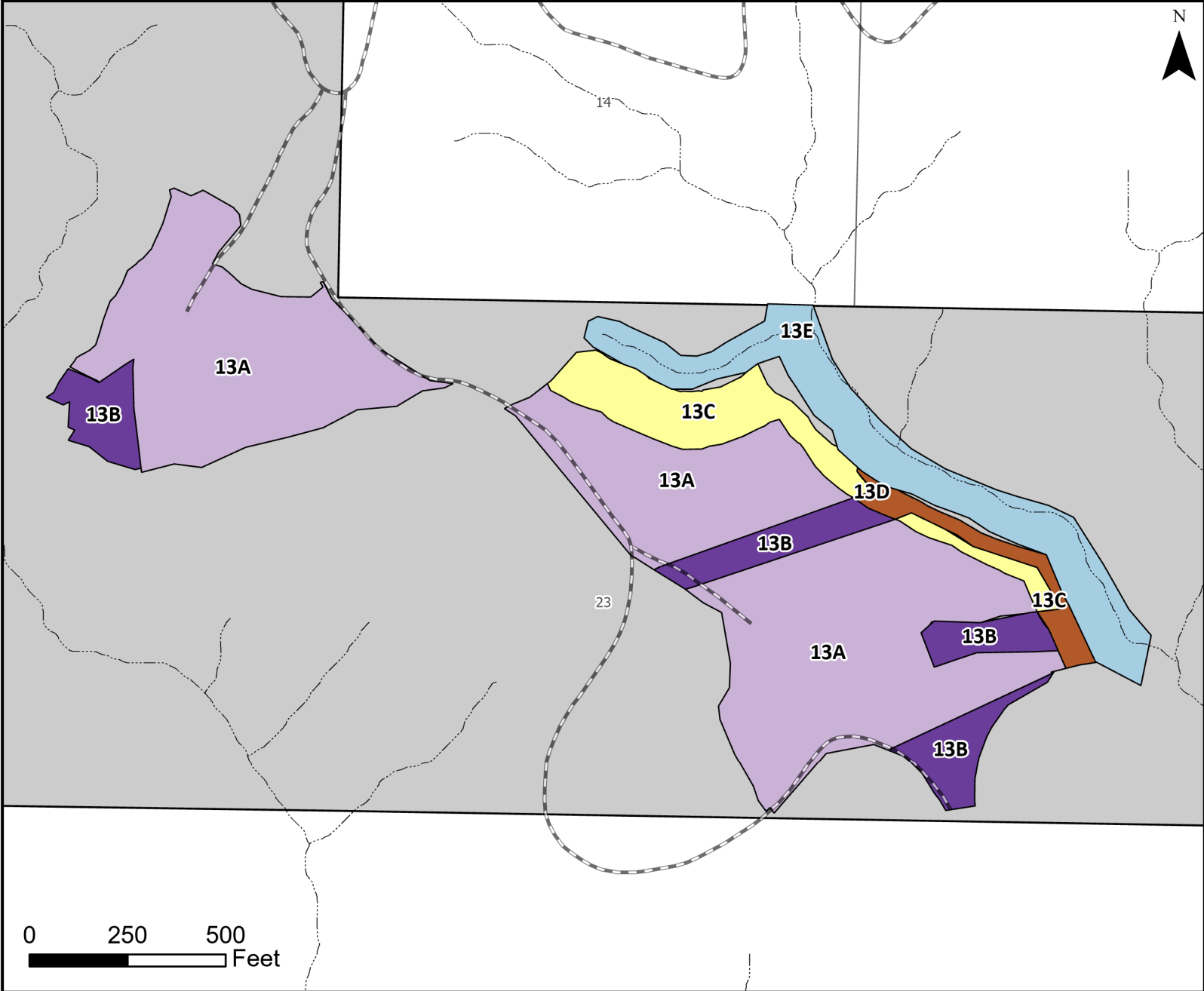

- Streams
- Project Roads
- Contract Area
- 13A
- 13B
- 13C
- 13D
- 13E

CWD Unit Number	CWD Unit Acres	Total Trees	Saw-top	High Girdle	Basal Girdle	Fell	Tree Size to be Selected (in. at DBH)
13A	20	120	22	22	76	0	15-20
13B	3	100	0	0	100	0	15-20
13C	3	10	3	3	4	0	15-20
13D	1	5	0	0	5	0	15-20
13E	5	15	0	0	15	0	15-20

No warranty is made by the Bureau of Land Management as to the accuracy, reliability, or completeness of these data for individual or aggregate use with other data. Original data were compiled from various sources and may be updated without notification. Note: Boundaries of harvest areas are painted/flagged in orange and posted. Right-of-ways (ROW) are posted. Harvest area acres do not include existing roads. Prepared By: dtyler



United States Department of the Interior
 BUREAU OF LAND MANAGEMENT
 TIMBER SALE CONTRACT MAP

Contract No. ORN04-TS-2023.0402
 Coastal Chrome Timber Sale
 Exhibit F
 Page 12 of 25

5/31/2023

T. 4S. R. 7W, Section 24 W. M. - NORTHWEST OREGON DISTRICT - OREGON

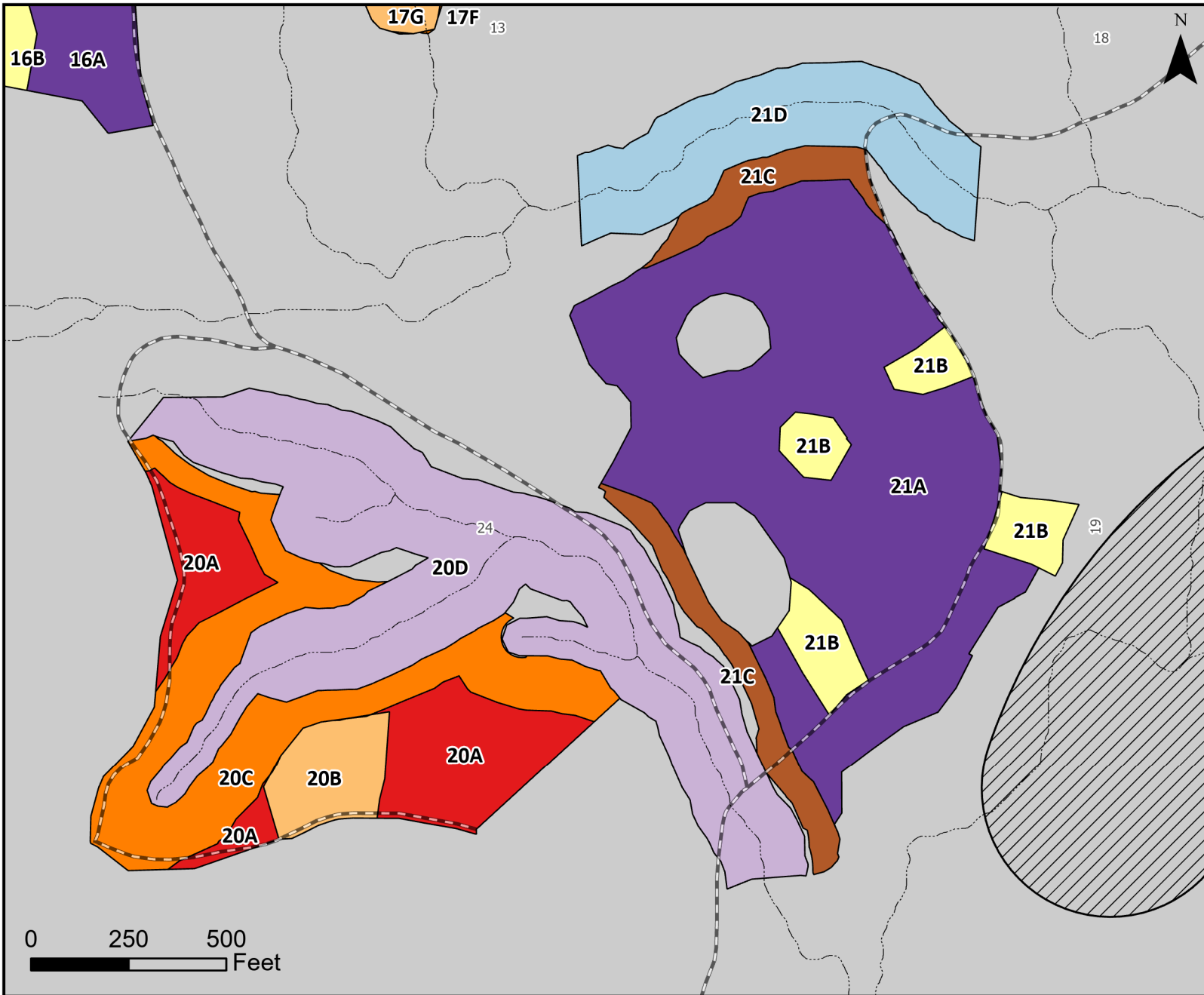

- Streams
- Project Roads
- Contract Area
- Restricted Operation Area
- 16A
- 16B
- 17F
- 17G
- 20A
- 20B
- 20C
- 20D
- 21A
- 21B
- 21C
- 21D

CWD Unit Number	CWD Unit Acres	Total Trees	Saw-top	High Girdle	Basal Girdle	Fell	Tree Size to be Selected (in. at DBH)
16A	7	72	12	12	48	0	15-20
17F	11	20	0	0	20	0	15-20
17G	7	28	0	0	0	28	21-30
20A	5	50	1	1	48	0	15-20
20B	2	10	5	5	0	0	15-20
20C	7	35	7	7	21	0	15-20
20D	16	35	0	0	35	0	15-20
21A	20	160	26	26	108	0	15-20
21B	3	100	0	0	100	0	15-20
21C	3	15	3	3	9	0	15-20
21D	6	15	0	0	15	0	15-20

No warranty is made by the Bureau of Land Management as to the accuracy, reliability, or completeness of these data for individual or aggregate use with other data. Original data were compiled from various sources and may be updated without notification. Note: Boundaries of harvest areas are painted/flagged in orange and posted. Right-of-ways (ROW) are posted. Harvest area acres do not include existing roads. Prepared By: dtyler



United States Department of the Interior
 BUREAU OF LAND MANAGEMENT
 TIMBER SALE CONTRACT MAP

Contract No. ORN04-TS-2023.0402
 Coastal Chrome Timber Sale
 Exhibit F
 Page 13 of 25

5/31/2023

T. 4S. R. 7W, Section 13 W. M. - NORTHWEST OREGON DISTRICT - OREGON

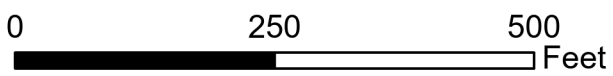
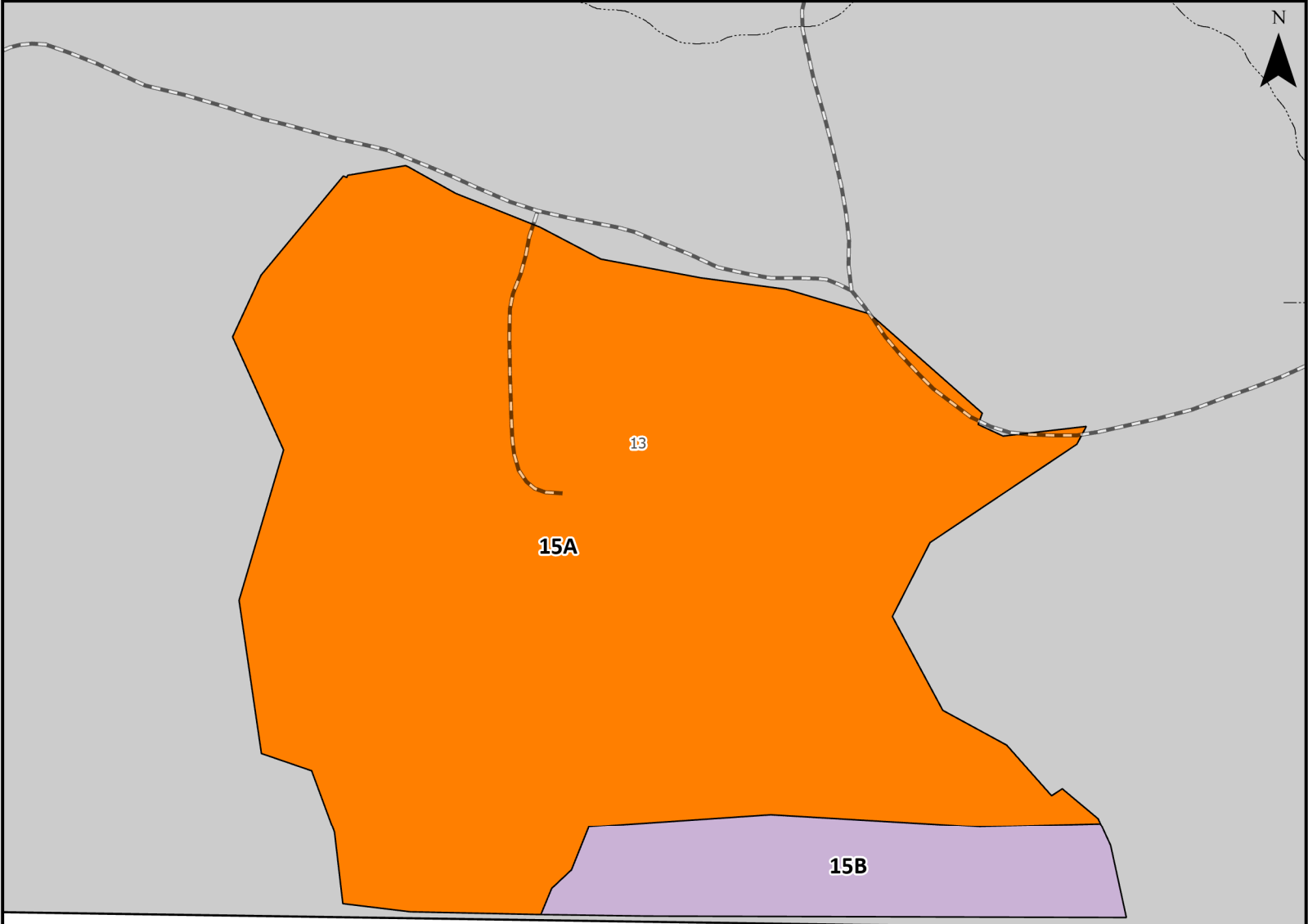

24

- Streams
- Project Roads
- Contract Area
- 15A
- 15B

CWD Unit Number	CWD Unit Acres	Total Trees	Saw-top	High Girdle	Basal Girdle	Fell	Tree Size to be Selected (in. at DBH)
15A	13	60	15	15	30	0	15-20
15B	2	90	0	0	90	0	15-20

No warranty is made by the Bureau of Land Management as to the accuracy, reliability, or completeness of these data for individual or aggregate use with other data. Original data were compiled from various sources and may be updated without notification. Note: Boundaries of harvest areas are painted/flagged in orange and posted. Right-of-ways (ROW) are posted. Harvest area acres do not include existing roads. Prepared By: dtyler



United States Department of the Interior
 BUREAU OF LAND MANAGEMENT
 TIMBER SALE CONTRACT MAP

Contract No. ORN04-TS-2023.0402
 Coastal Chrome Timber Sale
 Exhibit F
 Page 14 of 25

5/31/2023

T. 4S. R. 7W, Section 13 W. M. - NORTHWEST OREGON DISTRICT - OREGON

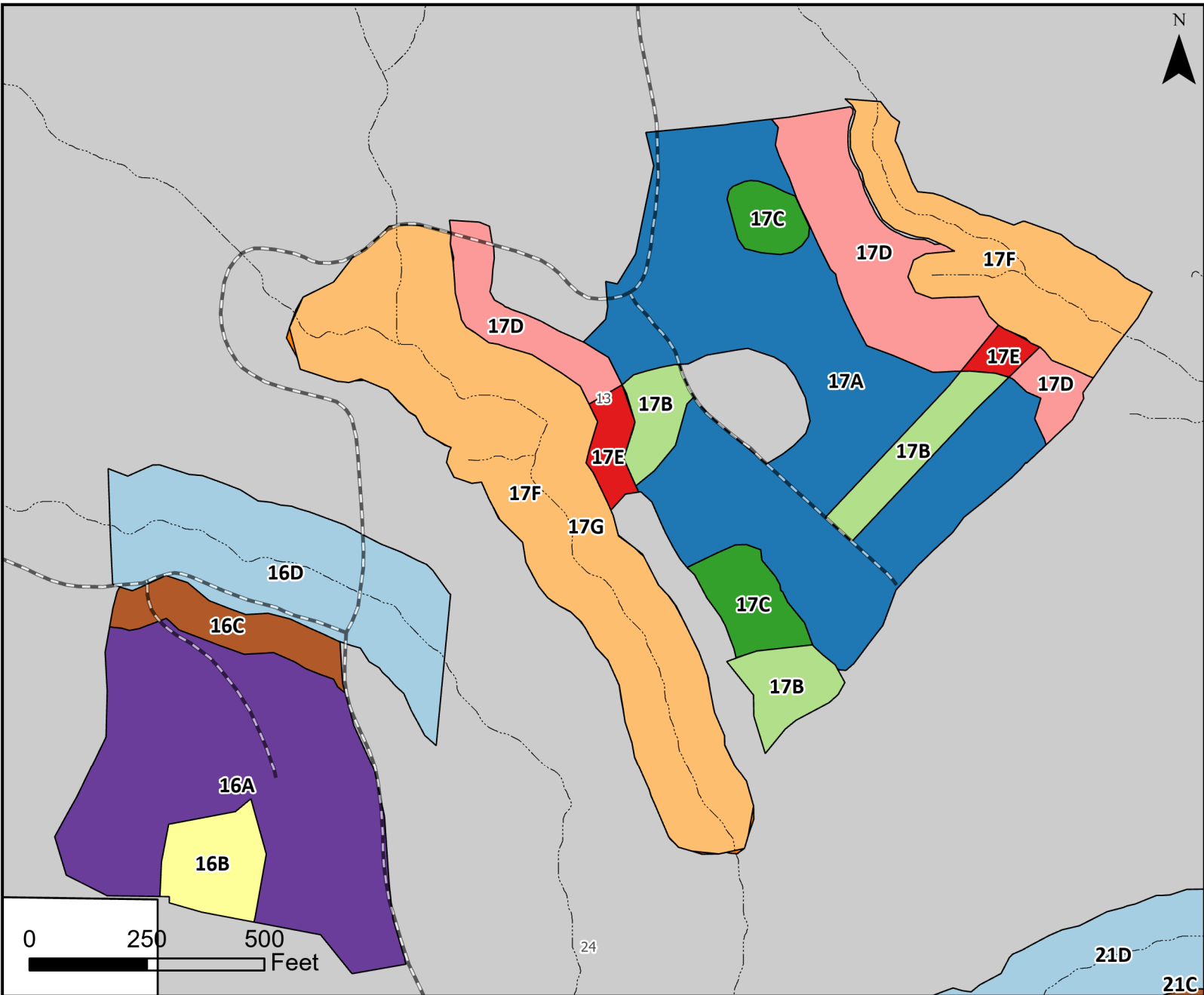

	Streams
	Project Roads
	Contract Area
	16A
	16B
	16C
	16D
	17A
	17B
	17C
	17D
	17E
	17F
	17G
	21C
	21D

CWD Unit Number	CWD Unit Acres	Total Trees	Saw-top	High Girdle	Basal Girdle	Fell	Tree Size to be Selected (in. at DBH)
16A	7	72	12	12	48	0	15-20
16B	1	8	4	4	0	0	15-20
16C	1	5	1	1	3	0	15-20
16D	4	5	0	0	5	0	15-20
17A	10	58	11	11	36	0	15-20
17B	2	84	0	0	84	0	15-20
17C	1	8	4	4	0	0	15-20
17D	4	10	4	4	2	0	15-20
17E	1	10	0	0	10	0	15-20
17F	11	20	0	0	20	0	15-20
17G	7	28	0	0	0	28	21-30
21D	6	15	0	0	15	0	15-20

No warranty is made by the Bureau of Land Management as to the accuracy, reliability, or completeness of these data for individual or aggregate use with other data. Original data were compiled from various sources and may be updated without notification. Note: Boundaries of harvest areas are painted/flagged in orange and posted. Right-of-ways (ROW) are posted. Harvest area acres do not include existing roads. Prepared By: dtyler



United States Department of the Interior
 BUREAU OF LAND MANAGEMENT
 TIMBER SALE CONTRACT MAP

Contract No. ORN04-TS-2023.0402
 Coastal Chrome Timber Sale
 Exhibit F
 Page 15 of 25

5/31/2023

T. 4S. R. 6W, Section 10 W. M. - NORTHWEST OREGON DISTRICT - OREGON

N

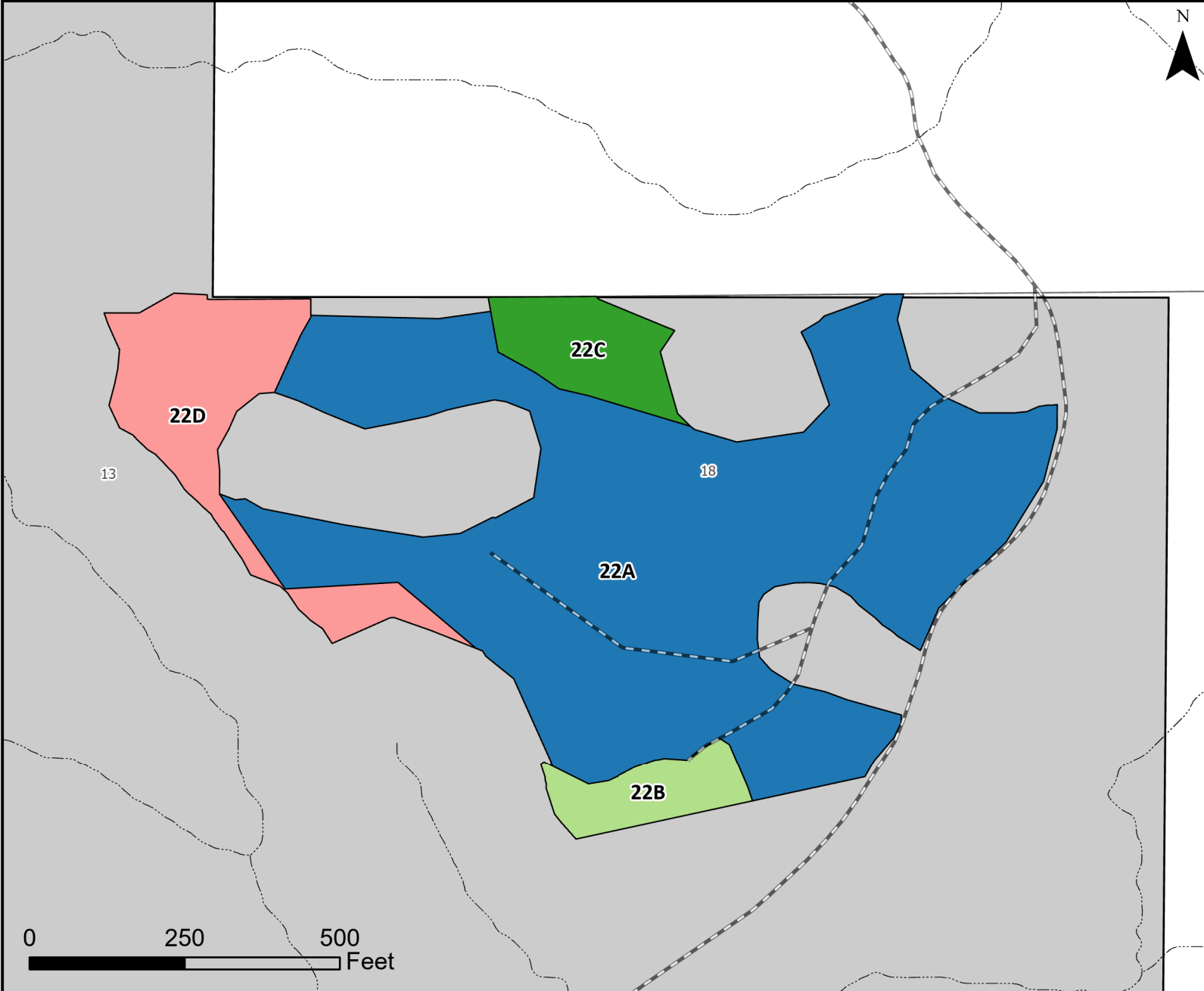

- Streams
- Project Roads
- Contract Area
- 22A
- 22B
- 22C
- 22D

CWD Unit Number	CWD Unit Acres	Total Trees	Saw-top	High Girdle	Basal Girdle	Fell	Tree Size to be Selected (in. at DBH)
22A	12	80	20	20	40	0	15-20
22B	1	30	0	0	30	0	15-20
22C	1	40	0	0	40	0	15-20
22D	2	50	0	0	50	0	15-20

No warranty is made by the Bureau of Land Management as to the accuracy, reliability, or completeness of these data for individual or aggregate use with other data. Original data were compiled from various sources and may be updated without notification. Note: Boundaries of harvest areas are painted/flagged in orange and posted. Right-of-ways (ROW) are posted. Harvest area acres do not include existing roads. Prepared By: dtyler



United States Department of the Interior
 BUREAU OF LAND MANAGEMENT
 TIMBER SALE CONTRACT MAP

Contract No. ORN04-TS-2023.0402
 Coastal Chrome Timber Sale
 Exhibit F
 Page 16 of 25

5/31/2023

T. 4S. R. 7W, Section 13 W. M. - NORTHWEST OREGON DISTRICT - OREGON

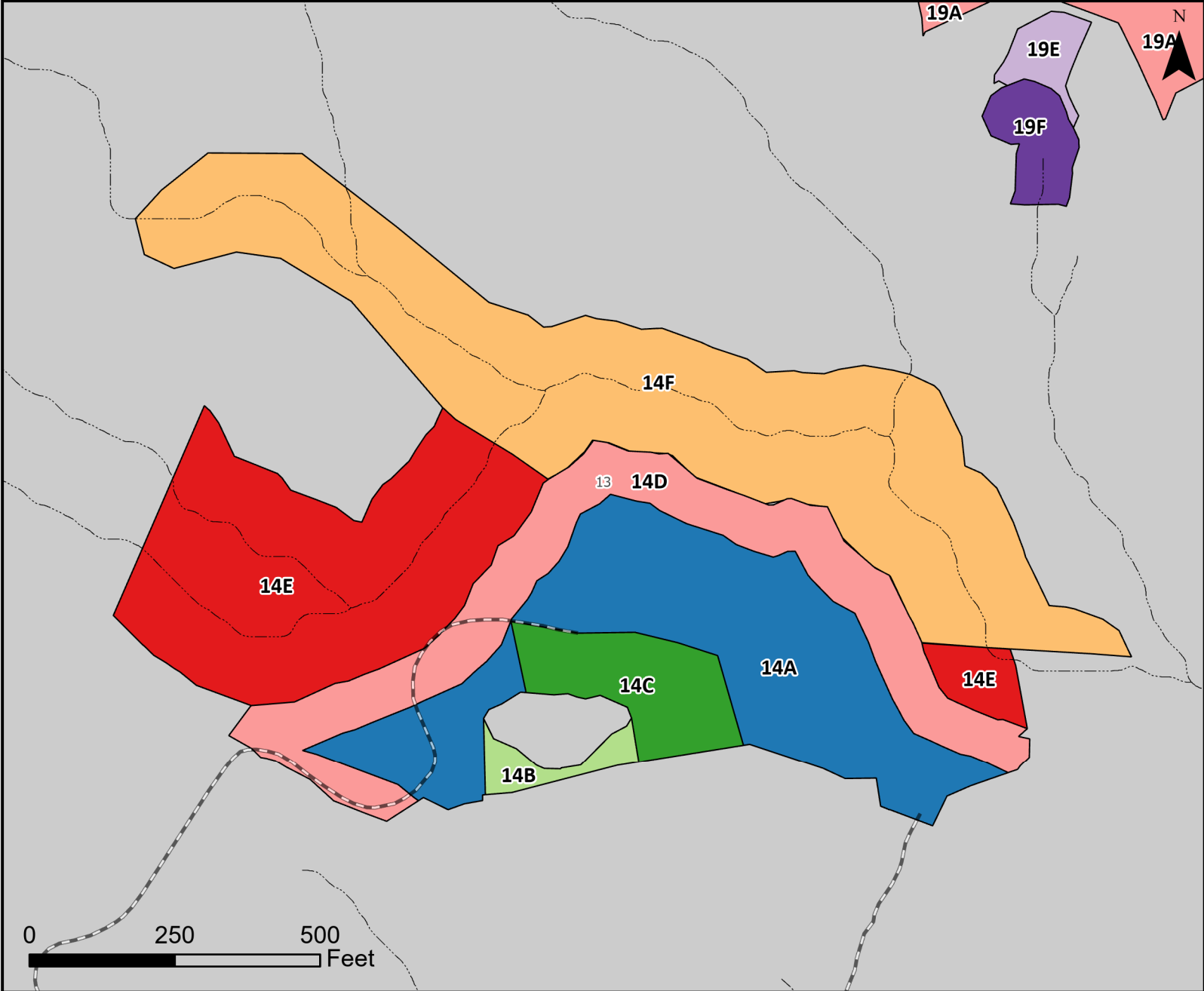

- - - - - Streams
 - - - - - Project Roads
 [Grey Box] Contract Area
 [Blue Box] 14A
 [Light Green Box] 14B
 [Green Box] 14C
 [Pink Box] 14D
 [Red Box] 14E
 [Orange Box] 14F
 [Light Red Box] 19A
 [Light Purple Box] 19E
 [Dark Purple Box] 19F

CWD Unit Number	CWD Unit Acres	Total Trees	Saw-top	High Girdle	Basal Girdle	Fell	Tree Size to be Selected (in. at DBH)
14A	5	35	1	1	33	0	15-20
14B	0	15	0	0	15	0	15-20
14C	1	10	5	5	0	0	15-20
14D	4	20	4	4	12	0	15-20
14E	6	20	0	0	20	0	15-20
14F	9	19	0	0	0	19	21-30
19A	12	60	10	10	40	0	15-20
19E	0	10	2	2	6	0	15-20
19F	1	10	0	0	10	0	15-20

No warranty is made by the Bureau of Land Management as to the accuracy, reliability, or completeness of these data for individual or aggregate use with other data. Original data were compiled from various sources and may be updated without notification. Note: Boundaries of harvest areas are painted/flagged in orange and posted. Right-of-ways (ROW) are posted. Harvest area acres do not include existing roads. Prepared By: dtyler



United States Department of the Interior
 BUREAU OF LAND MANAGEMENT
 TIMBER SALE CONTRACT MAP

Contract No. ORN04-TS-2023.0402
 Coastal Chrome Timber Sale
 Exhibit F
 Page 17 of 25

5/31/2023

T. 4S. R. 7W, Section 13 W. M. - NORTHWEST OREGON DISTRICT - OREGON

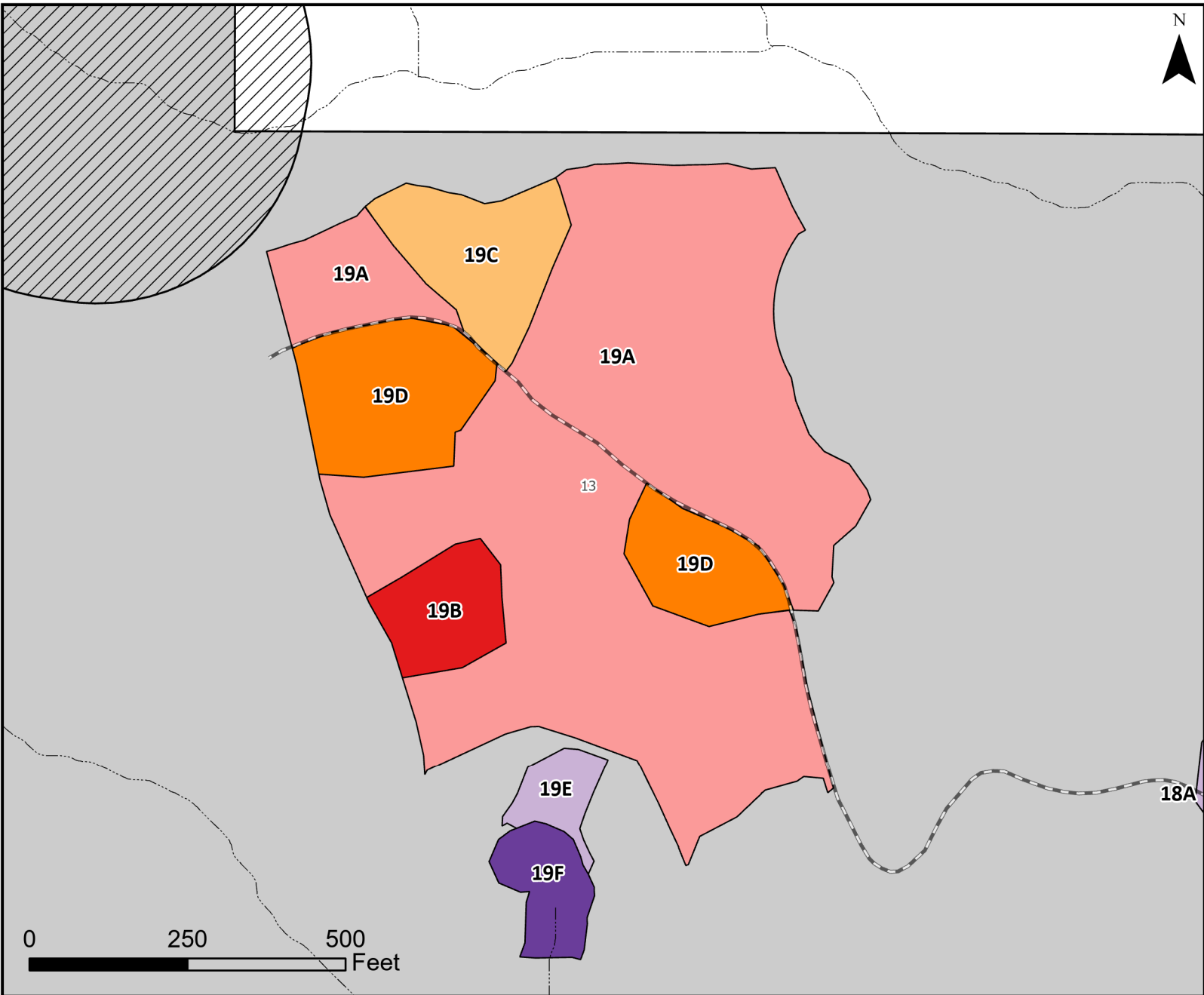

- Streams
- Project Roads
- Contract Area
- Restricted Operation Area
- 18A
- 19A
- 19B
- 19C
- 19D
- 19E
- 19F

CWD Unit Number	CWD Unit Acres	Total Trees	Saw-top	High Girdle	Basal Girdle	Fell	Tree Size to be Selected (in. at DBH)
19A	12	60	10	10	40	0	15-20
19B	1	50	0	0	50	0	15-20
19C	1	30	0	0	30	0	15-20
19D	2	10	5	5	0	0	15-20
19E	0	10	2	2	6	0	15-20
19F	1	10	0	0	10	0	15-20

No warranty is made by the Bureau of Land Management as to the accuracy, reliability, or completeness of these data for individual or aggregate use with other data. Original data were compiled from various sources and may be updated without notification. Note: Boundaries of harvest areas are painted/flagged in orange and posted. Right-of-ways (ROW) are posted. Harvest area acres do not include existing roads. Prepared By: dtyler



United States Department of the Interior
 BUREAU OF LAND MANAGEMENT
 TIMBER SALE CONTRACT MAP

Contract No. ORN04-TS-2023.0402
 Coastal Chrome Timber Sale
 Exhibit F
 Page 18 of 25

5/31/2023

T. 4S. R. 7W, Section 13 W. M. - NORTHWEST OREGON DISTRICT - OREGON

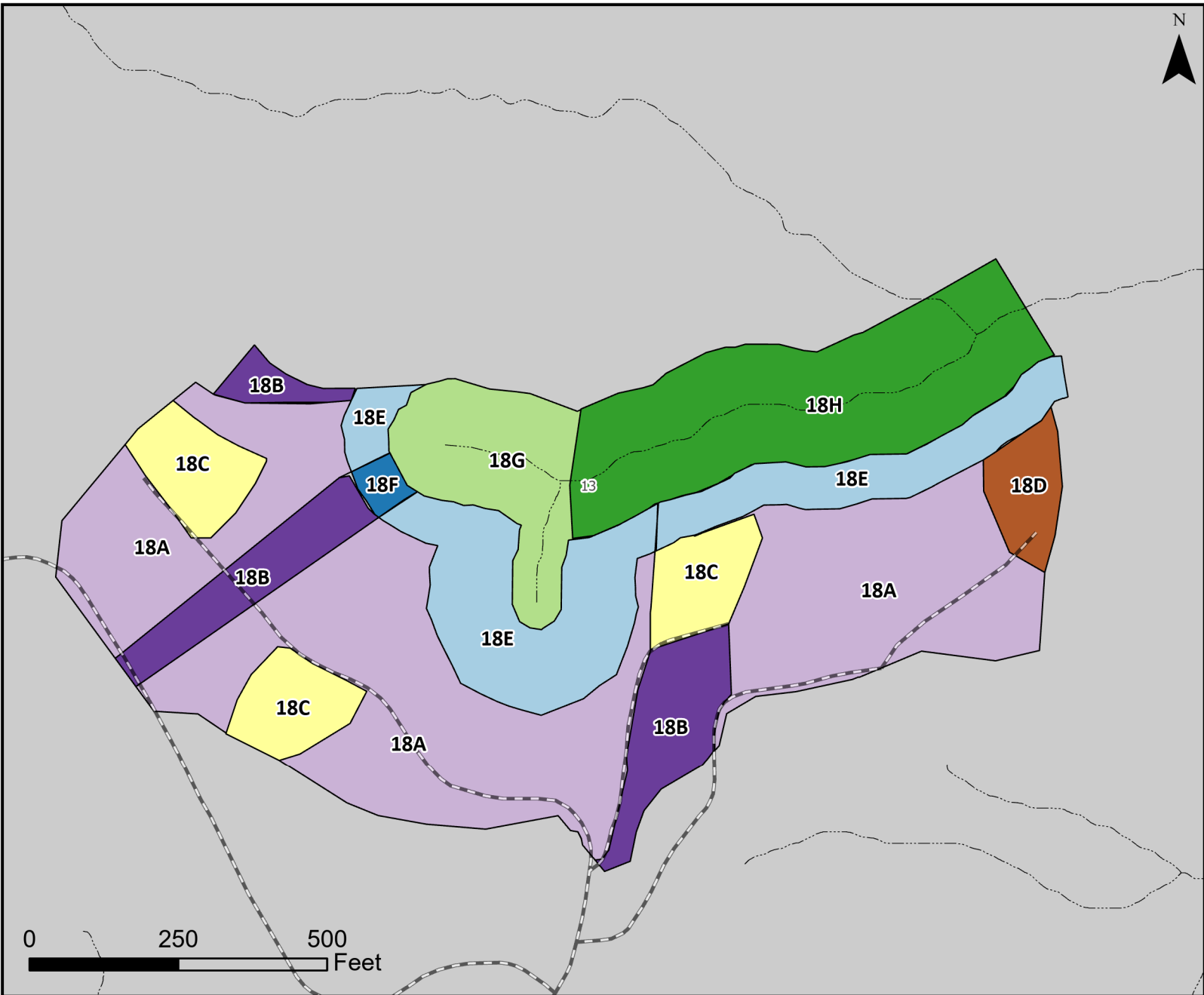

- Streams
- Project Roads
- Contract Area
- 18A
- 18B
- 18C
- 18D
- 18E
- 18F
- 18G
- 18H

CWD Unit Number	CWD Unit Acres	Total Trees	Saw-top	High Girdle	Basal Girdle	Fell	Tree Size to be Selected (in. at DBH)
18A	10	79	5	5	69	0	15-20
18B	2	30	0	0	30	0	15-20
18C	2	15	5	5	5	0	15-20
18D	1	6	3	3	0	0	15-20
18E	4	15	4	4	7	0	15-20
18F	0	5	0	0	5	0	15-20
18G	2	20	0	0	20	0	15-20
18H	4	42	0	0	0	42	15-20

No warranty is made by the Bureau of Land Management as to the accuracy, reliability, or completeness of these data for individual or aggregate use with other data. Original data were compiled from various sources and may be updated without notification. Note: Boundaries of harvest areas are painted/flagged in orange and posted. Right-of-ways (ROW) are posted. Harvest area acres do not include existing roads. Prepared By: dtyler



United States Department of the Interior
 BUREAU OF LAND MANAGEMENT
 TIMBER SALE CONTRACT MAP

Contract No. ORN04-TS-2023.0402
 Coastal Chrome Timber Sale
 Exhibit F
 Page 19 of 25

5/31/2023

T. 4S. R. 7W, Section 14 W. M. - NORTHWEST OREGON DISTRICT - OREGON

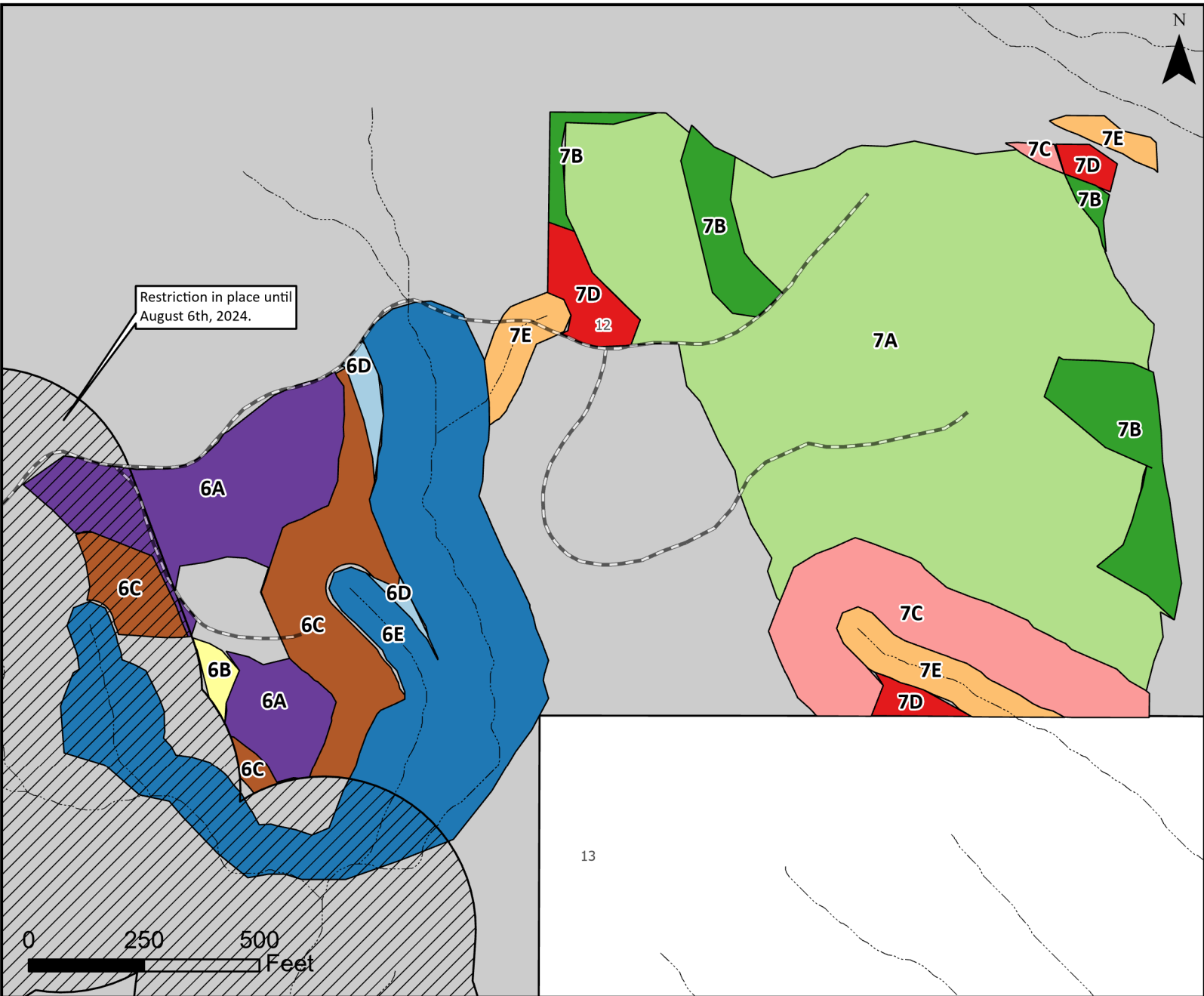

Restriction in place until
 August 6th, 2024.

0 250 500 Feet

	Streams
	Project Roads
	Contract Area
	Restricted Operation Area
	6A
	6B
	6C
	6D
	6E
	7A
	7B
	7C
	7D
	7E

CWD Unit Number	CWD Unit Acres	Total Trees	Saw-top	High Girdle	Basal Girdle	Fell	Tree Size to be Selected (in. at DBH)
6A	5	20	5	5	10	0	15-20
6B	0	30	0	0	30	0	15-20
6C	3	17	4	4	9	0	15-20
6D	0	3	0	0	3	0	15-20
6E	10	20	0	0	20	0	15-20
7A	21	145	24	24	97	0	15-20
7B	3	95	0	0	95	0	15-20
7C	4	8	4	4	0	0	15-20
7D	1	12	0	0	12	0	15-20
7E	2	20	0	0	20	0	15-20

No warranty is made by the Bureau of Land Management as to the accuracy, reliability, or completeness of these data for individual or aggregate use with other data. Original data were compiled from various sources and may be updated without notification. Note: Boundaries of harvest areas are painted/flagged in orange and posted. Right-of-ways (ROW) are posted. Harvest area acres do not include existing roads. Prepared By: dtyler



United States Department of the Interior
 BUREAU OF LAND MANAGEMENT
 TIMBER SALE CONTRACT MAP

Contract No. ORN04-TS-2023.0402
 Coastal Chrome Timber Sale
 Exhibit F
 Page 20 of 25

5/31/2023

T. 4S. R. 7W, Section 14 W. M. - NORTHWEST OREGON DISTRICT - OREGON

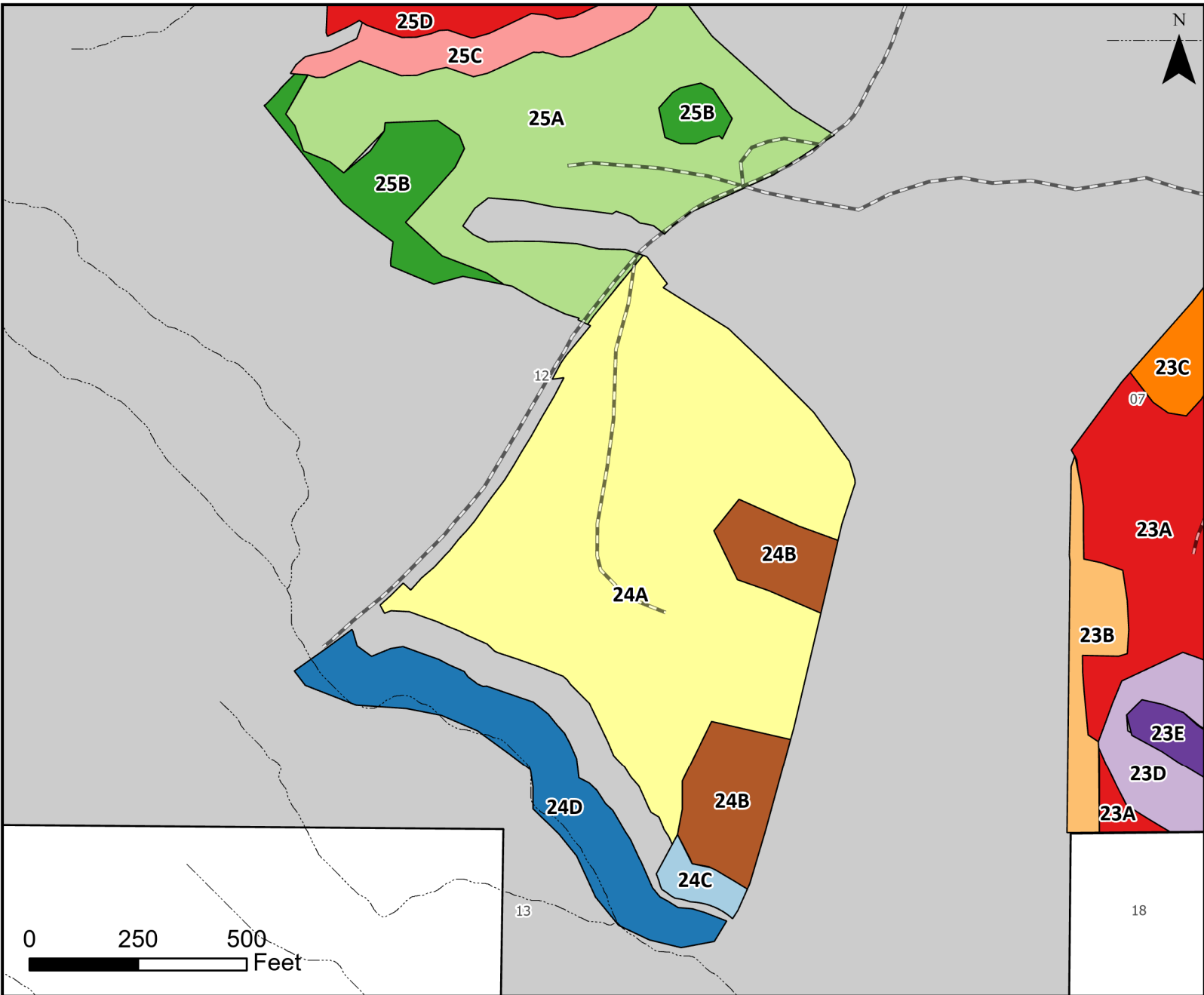

- Streams
- Project Roads
- Contract Area
- 23A
- 23B
- 23C
- 23D
- 23E
- 24A
- 24B
- 24C
- 24D
- 24D
- 25A
- 25B
- 25C
- 25D

CWD Unit Number	CWD Unit Acres	Total Trees	Saw-top	High Girdle	Basal Girdle	Fell	Tree Size to be Selected (in. at DBH)
24A	15	90	18	18	54	0	15-20
24B	2	90	0	0	90	0	15-20
24C	0	10	2	2	6	0	15-20
24D	3	10	0	0	10	0	15-20
25A	9	60	15	15	30	0	15-20
25B	2	90	0	0	90	0	15-20
25C	3	10	2	2	6	0	15-20
25D	5	10	0	0	10	0	15-20

No warranty is made by the Bureau of Land Management as to the accuracy, reliability, or completeness of these data for individual or aggregate use with other data. Original data were compiled from various sources and may be updated without notification. Note: Boundaries of harvest areas are painted/flagged in orange and posted. Right-of-ways (ROW) are posted. Harvest area acres do not include existing roads. Prepared By: dtyler



United States Department of the Interior
 BUREAU OF LAND MANAGEMENT
 TIMBER SALE CONTRACT MAP

Contract No. ORN04-TS-2023.0402
 Coastal Chrome Timber Sale
 Exhibit F
 Page 21 of 25

5/31/2023

T. 4S. R. 6W, Section 7 W. M. - NORTHWEST OREGON DISTRICT - OREGON

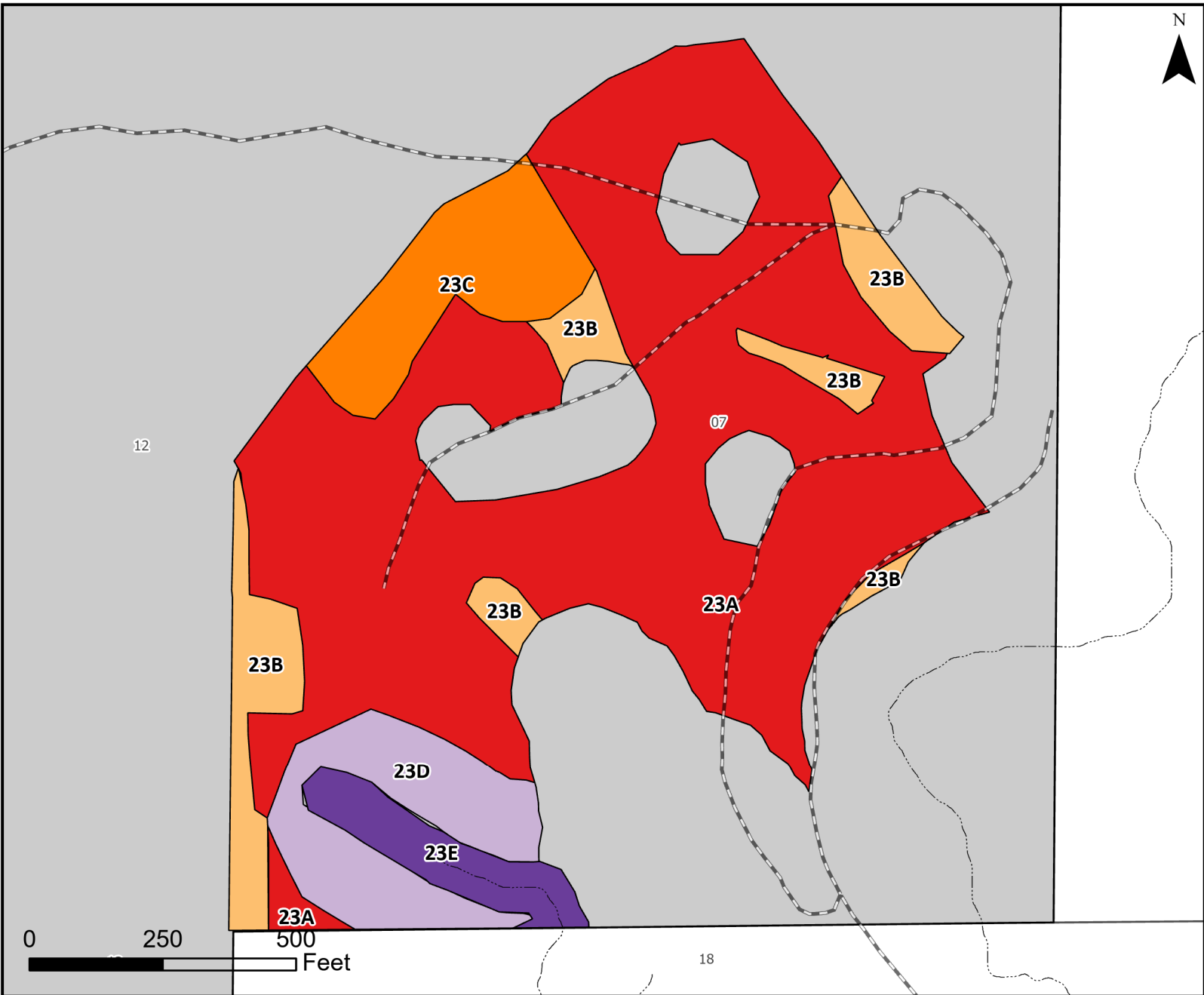

- Streams
- Project Roads
- Contract Area
- 23A
- 23B
- 23C
- 23D
- 23E

CWD Unit Number	CWD Unit Acres	Total Trees	Saw-top	High Girdle	Basal Girdle	Fell	Tree Size to be Selected (in. at DBH)
23A	21	180	25	25	130	0	15-20
23B	3	110	0	0	110	0	15-20
23C	2	10	5	5	0	0	15-20
23D	3	15	3	3	9	0	15-20
23E	1	15	0	0	15	0	15-20

No warranty is made by the Bureau of Land Management as to the accuracy, reliability, or completeness of these data for individual or aggregate use with other data. Original data were compiled from various sources and may be updated without notification. Note: Boundaries of harvest areas are painted/flagged in orange and posted. Right-of-ways (ROW) are posted. Harvest area acres do not include existing roads. Prepared By: dtyler



United States Department of the Interior
 BUREAU OF LAND MANAGEMENT
 TIMBER SALE CONTRACT MAP

Contract No. ORN04-TS-2023.0402
 Coastal Chrome Timber Sale
 Exhibit F
 Page 22 of 25

5/31/2023

T. 4S. R. 7W, Section 14 W. M. - NORTHWEST OREGON DISTRICT - OREGON

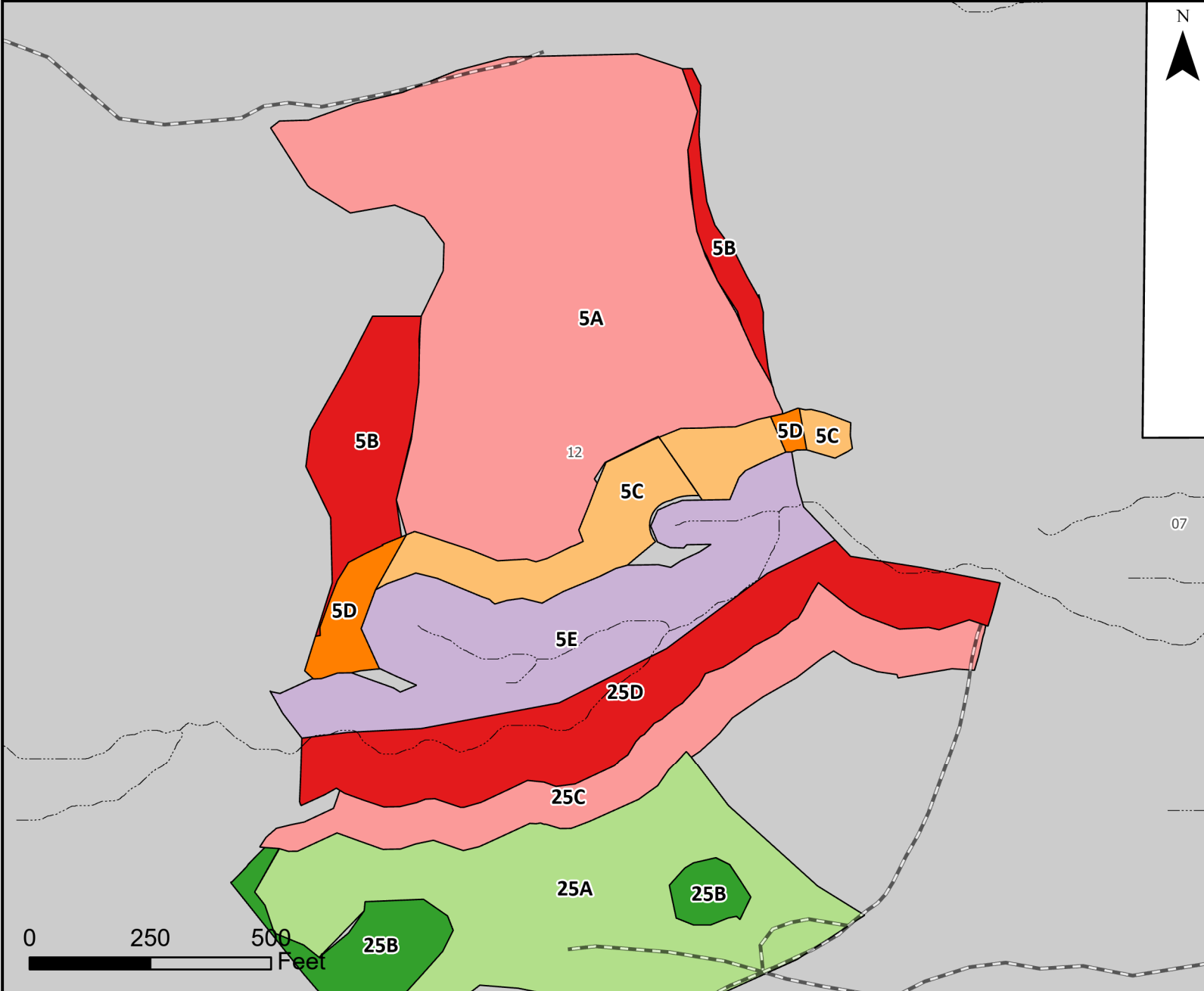

- Streams
- Project Roads
- Contract Area
- 25A
- 25B
- 25C
- 25D
- 5A
- 5B
- 5C
- 5D
- 5E

CWD Unit Number	CWD Unit Acres	Total Trees	Saw-top	High Girdle	Basal Girdle	Fell	Tree Size to be Selected (in. at DBH)
25A	9	60	15	15	30	0	15-20
25B	2	90	0	0	90	0	15-20
25C	3	10	2	2	6	0	15-20
25D	5	10	0	0	10	0	15-20
5A	14	88	17	17	54	0	15-20
5B	2	82	0	0	82	0	15-20
5C	2	6	3	3	0	0	15-20
5D	1	9	0	0	9	0	15-20
5E	6	15	0	0	15	0	15-20

No warranty is made by the Bureau of Land Management as to the accuracy, reliability, or completeness of these data for individual or aggregate use with other data. Original data were compiled from various sources and may be updated without notification. Note: Boundaries of harvest areas are painted/flagged in orange and posted. Right-of-ways (ROW) are posted. Harvest area acres do not include existing roads. Prepared By: dtyler



United States Department of the Interior
 BUREAU OF LAND MANAGEMENT
 TIMBER SALE CONTRACT MAP

Contract No. ORN04-TS-2023.0402
 Coastal Chrome Timber Sale
 Exhibit F
 Page 23 of 25

5/31/2023

T. 4S. R. 7W, Section 14 W. M. - NORTHWEST OREGON DISTRICT - OREGON

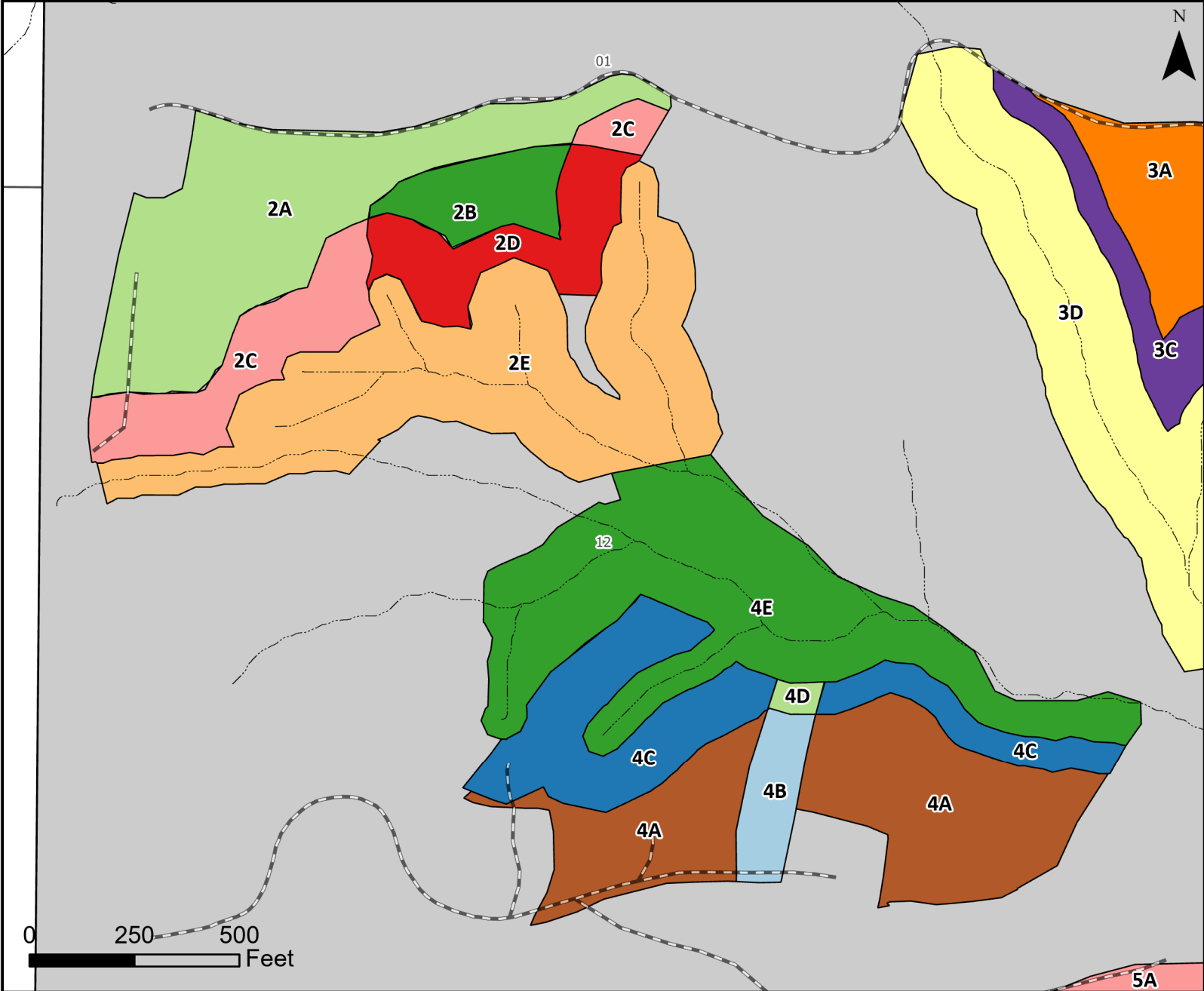

	CWD Unit Number	CWD Unit Acres	Total Trees	Saw-top	High Girdle	Basal Girdle	Fell	Tree Size to be Selected (in. at DBH)
--- Streams								
--- Project Roads								
Contract Area								
2A	2A	8	36	9	9	18	0	15-20
2B	2B	2	54	0	0	54	0	15-20
2C	2C	3	10	5	5	0	0	15-20
2D	2D	3	15	0	0	15	0	15-20
2E	2E	10	25	0	0	25	0	15-20
3A	3A	23	100	26	26	48	0	15-20
3C	3C	5	25	5	5	15	0	15-20
3D	3D	11	25	0	0	25	0	15-20
4A	4A	8	65	11	11	43	0	15-20
4B	4B	1	45	0	0	45	0	15-20
4C	4C	5	20	5	5	0	0	15-20
4D	4D	0	5	0	0	15	0	15-20
4E	4E	10	25	0	0	25	0	15-20
5A	5A							

No warranty is made by the Bureau of Land Management as to the accuracy, reliability, or completeness of these data for individual or aggregate use with other data. Original data were compiled from various sources and may be updated without notification. Note: Boundaries of harvest areas are painted/flagged in orange and posted. Right-of-ways (ROW) are posted. Harvest area acres do not include existing roads. Prepared By: dtyler



United States Department of the Interior
 BUREAU OF LAND MANAGEMENT
 TIMBER SALE CONTRACT MAP

Contract No. ORN04-TS-2023.0402
 Coastal Chrome Timber Sale
 Exhibit F
 Page 24 of 25

5/31/2023

T. 4S. R. 7W, Section 14 W. M. - NORTHWEST OREGON DISTRICT - OREGON

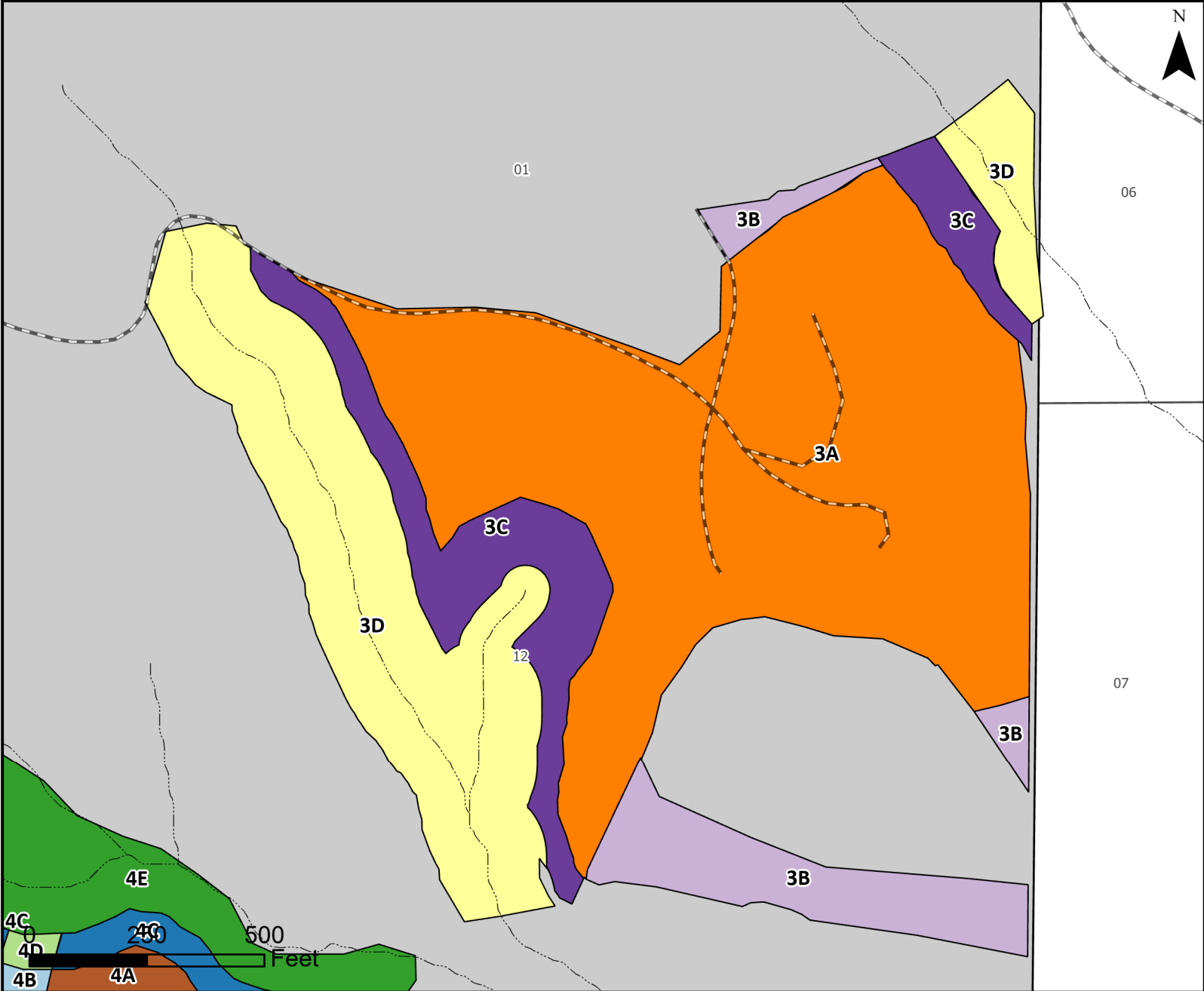

- Streams
- Project Roads
- Contract Area
- 3A
- 3B
- 3C
- 3D
- 4A
- 4B
- 4C
- 4D
- 4E

CWD Unit Number	CWD Unit Acres	Total Trees	Saw-top	High Girdle	Basal Girdle	Fell	Tree Size to be Selected (in. at DBH)
3A	23	100	26	26	48	0	15-20
3B	4	160	0	0	160	0	15-20
3C	5	25	5	5	15	0	15-20
3D	11	25	0	0	25	0	15-20
4A	8	65	11	11	43	0	15-20
4C	5	20	5	5	0	0	15-20
4E	10	25	0	0	25	0	15-20

No warranty is made by the Bureau of Land Management as to the accuracy, reliability, or completeness of these data for individual or aggregate use with other data. Original data were compiled from various sources and may be updated without notification. Note: Boundaries of harvest areas are painted/flagged in orange and posted. Right-of-ways (ROW) are posted. Harvest area acres do not include existing roads. Prepared By: dtyler



United States Department of the Interior
 BUREAU OF LAND MANAGEMENT
 TIMBER SALE CONTRACT MAP

Contract No. ORN04-TS-2023.0402
 Coastal Chrome Timber Sale
 Exhibit F
 Page 25 of 25

5/31/2023

T. 4S. R. 6W, Sections 6 & 7 W. M. - NORTHWEST OREGON DISTRICT - OREGON

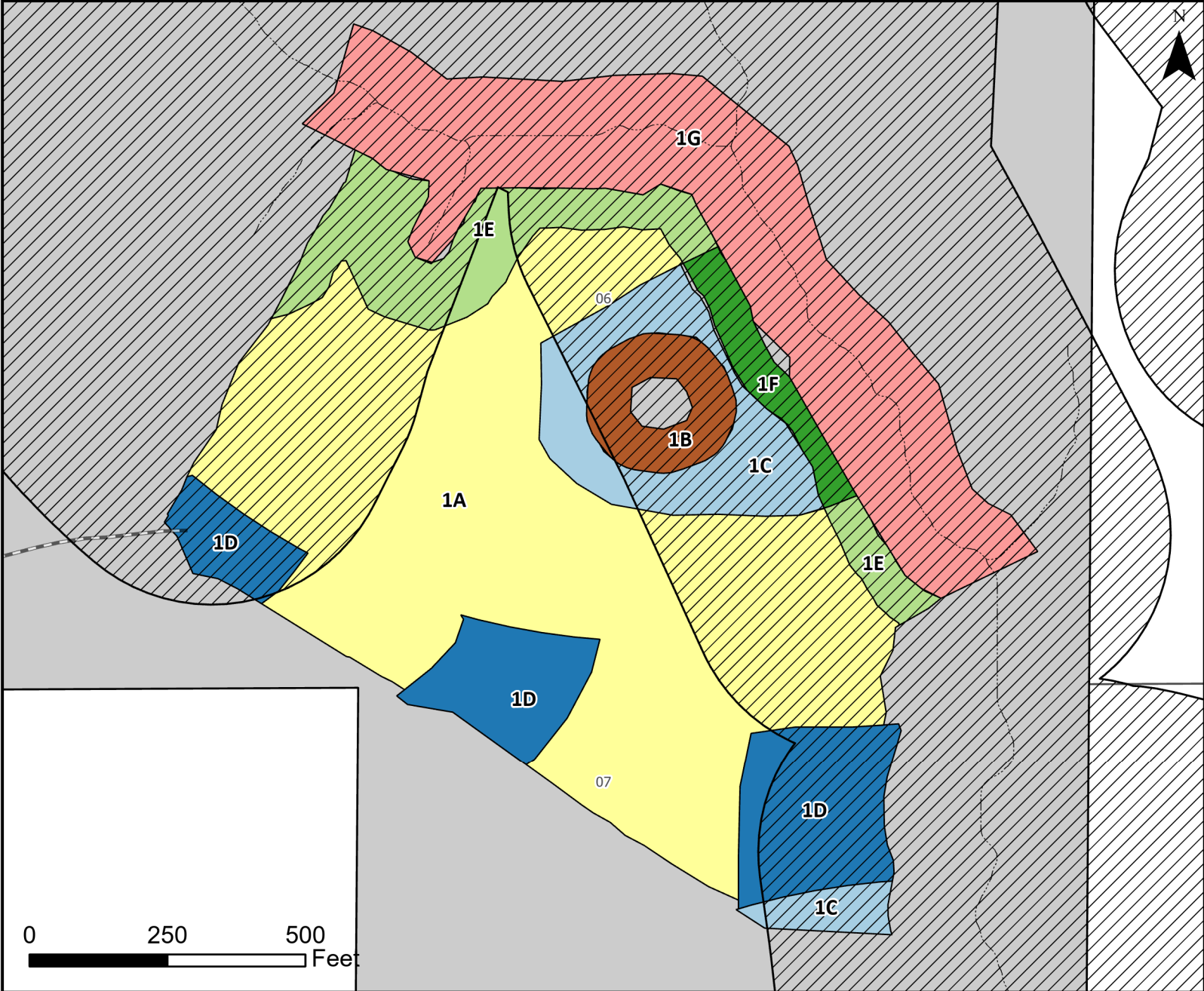

- - - - - Streams
 - - - - - Project Roads
 [Grey Box] Contract Area
 [Hatched Box] Restricted Operation Area
 [Yellow Box] 1A
 [Brown Box] 1B
 [Light Blue Box] 1C
 [Dark Blue Box] 1D
 [Light Green Box] 1E
 [Dark Green Box] 1F
 [Red Box] 1G

CWD Unit Number	CWD Unit Acres	Total Trees	Saw-top	High Girdle	Basal Girdle	Fell	Tree Size to be Selected (in. at DBH)
1A	15	72	13	13	46	0	15-20
1B	1	50	0	0	50	0	15-20
1C	3	88	0	0	88	0	15-20
1D	4	20	10	10	0	0	15-20
1E	3	5	3	2	0	0	15-20
1F	1	10	0	1	9	0	15-20
1G	8	15	0	0	15	0	15-20

No warranty is made by the Bureau of Land Management as to the accuracy, reliability, or completeness of these data for individual or aggregate use with other data. Original data were compiled from various sources and may be updated without notification. Note: Boundaries of harvest areas are painted/flagged in orange and posted. Right-of-ways (ROW) are posted. Harvest area acres do not include existing roads. Prepared By: dtyler

Legal Description of Contract Area

Land Status	County	Township	Range	Section	Subdivision	Meridian
O&C	Tillamook	4S	6W	6	SE $\frac{1}{4}$ SW $\frac{1}{4}$, SW $\frac{1}{4}$ SE $\frac{1}{4}$	Willamette
O&C	Tillamook	4S	6W	7	NW $\frac{1}{4}$ NE $\frac{1}{4}$	Willamette
O&C	Tillamook	4S	6W	18	SW $\frac{1}{4}$ SW $\frac{1}{4}$	Willamette
O&C	Yamhill	4S	6W	19	W $\frac{1}{2}$ NW $\frac{1}{4}$	Willamette
O&C	Tillamook	4S	7W	1	SE $\frac{1}{4}$ SW $\frac{1}{4}$, S $\frac{1}{2}$ SE $\frac{1}{4}$	Willamette
O&C	Tillamook	4S	7W	12	NE $\frac{1}{4}$, E $\frac{1}{2}$ NW $\frac{1}{4}$, SW $\frac{1}{4}$, SE $\frac{1}{4}$	Willamette
O&C	Tillamook	4S	7W	13	NE $\frac{1}{4}$ NE $\frac{1}{4}$, S $\frac{1}{2}$ NE $\frac{1}{4}$, NW $\frac{1}{4}$ NW $\frac{1}{4}$, SE $\frac{1}{4}$ NW $\frac{1}{4}$, S $\frac{1}{2}$,	Willamette
O&C	Tillamook	4S	7W	14	E $\frac{1}{2}$ SW $\frac{1}{4}$, NW $\frac{1}{4}$ SE $\frac{1}{4}$	Willamette
O&C	Tillamook	4S	7W	15	NE $\frac{1}{4}$, SE $\frac{1}{4}$ NW $\frac{1}{4}$, N $\frac{1}{2}$ SE $\frac{1}{4}$	Willamette
O&C	Yamhill	4S	7W	23	N $\frac{1}{2}$ NE $\frac{1}{4}$, NE $\frac{1}{4}$ NW $\frac{1}{4}$	Willamette
O&C	Yamhill	4S	7W	24	NE $\frac{1}{4}$	Willamette
O&C	Yamhill	5S	7W	11	SW $\frac{1}{4}$, SW $\frac{1}{4}$ SE $\frac{1}{4}$	Willamette
O&C	Yamhill	5S	7W	15	NE $\frac{1}{4}$ NE $\frac{1}{4}$, S $\frac{1}{2}$ NE $\frac{1}{4}$, S $\frac{1}{2}$ NW $\frac{1}{4}$, SW $\frac{1}{4}$, N $\frac{1}{2}$ SE $\frac{1}{4}$, SW $\frac{1}{4}$ SE $\frac{1}{4}$,	Willamette

Species Totals

Species	Net	Gross Merch	Gross	# of Merch Logs	# of Cull Logs	# of Trees
Douglas Fir	15,025.0	15,582.0	15,616.0	250,526	807	63,966
Noble Fir	1,711.0	1,810.0	1,818.0	14,908	50	2,685
Western Hemlock	72.0	77.0	77.0	591	0	85
Red Alder	63.0	107.0	118.0	1,394	1,820	1,445
Bigleaf Maple	12.0	23.0	24.0	285	280	299
Totals	16,883.0	17,599.0	17,653.0	267,704	2,957	68,480

Cutting Area Acres

Regeneration Harvest Acres	Partial Cut Acres	Right of Way Acres	Total Acres	Net Volume per Acre
103.0	780.0	8.0	891.0	18.9

Logging Costs

Stump to Truck	\$3,730,182.67
Transportation	\$839,040.00
Road Construction	\$1,685,066.87
Maintenance/Rockwear	\$188,522.43
Road Use	\$0.00
Other Allowances	\$343,000.00
Total:	\$6,785,811.97
Total Logging Cost per MBF:	\$401.93

Utilization Centers

<u>Location</u>	<u>Distance</u>	<u>% of Net Volume</u>
Willamina	25.0 miles	99%
Garibaldi	51.0 miles	1%

Profit & Risk

Profit	11%
Risk	5%
Total Profit & Risk	16%

Tract Features

Quadratic Mean DBH	15.2 in
Average GM Log	65 bf
Average Volume per Acre	18.9 mbf
Recovery	96%
<u>Net MBF volume:</u>	
Green	16,883.0 mbf
Salvage	0 mbf
Export	0 mbf
<u>Ground Base Logging:</u>	
Percent of Sale Volume	84%
Average Yarding Slope	35%
Average Yarding Distance	600 ft
<u>Cable Logging:</u>	
Percent of Sale Volume	16%
Average Yarding Slope	55%
Average Yarding Distance	800 ft
<u>Aerial Logging:</u>	
Percent of Sale Volume	0%
Average Yarding Slope	0%
Average Yarding Distance	0 ft

Cruise

Cruise Completed	February 2023
Cruised By	Bryant/Salmon
Cruise Method	variable plot 20 BAF in the reserve tree marked units variable plot 40 BAF in the cut tree marked units. Variable plot 40 BAF in the Regen units. 100 % cruise on RW volume.

Stumpage Computation

Species	# of Trees	Net Volume	Pond Value	(-) Profit & Risk	(-) Logging Costs	(+) Marginal Log Value	Stumpage Adjustment	Appraised Price/MBF	Appraised Value (\$)
Douglas Fir	63,966	15,025.0	\$621.18	\$99.39	\$401.93	\$0.00	(\$8.49)	\$111.40	\$1,673,785.00
Noble Fir	2,685	1,711.0	\$458.26	\$73.32	\$401.93	\$0.00	\$0.00	\$45.90 *	\$78,534.90
Western Hemlock	85	72.0	\$462.35	\$73.98	\$401.93	\$0.00	\$0.00	\$46.30 *	\$3,333.60
Red Alder	1,445	63.0	\$257.07	\$41.13	\$401.93	\$0.00	\$0.00	\$25.80 *	\$1,625.40
Bigleaf Maple	299	12.0	\$262.50	\$42.00	\$401.93	\$0.00	\$0.00	\$26.30 *	\$315.60
Totals	68,480	16,883.0							\$1,757,594.50

* Minimum Stumpage values were used to compute the Appraised Price/MBF (10% of Pond Value)

Percent of Volume By Log Grade

Species	No. 1 & 2 Peeler	No. 3 Peeler	Special Mill	No. 2 Sawmill	No. 3 Sawmill	No. 4 Sawmill	Camp Run
Douglas Fir				41.0%	53.0%	6.0%	

Species	Peeler	No. 1 Sawmill	Special Mill	No. 2 Sawmill	No. 3 Sawmill	No. 4 Sawmill	Camp Run
Noble Fir				73.0%	26.0%	1.0%	

Species	Peeler	No. 1 Sawmill	Special Mill	No. 2 Sawmill	No. 3 Sawmill	No. 4 Sawmill	Camp Run
Western Hemlock				79.0%	20.0%	1.0%	

Species	No. 1 Sawmill	No. 2 Sawmill	No. 3 Sawmill	No. 4 Sawmill	No. 5 Sawmill		Camp Run
Red Alder							100.0%

Species	No. 1 Sawmill	No. 2 Sawmill	No. 3 Sawmill	No. 4 Sawmill	No. 5 Sawmill		Camp Run
Bigleaf Maple							100.0%

Unit: 1

Species	Net	Gross Merch	Gross	# of Trees
Douglas Fir	295.0	307.0	307.0	1,531
Red Alder	4.0	7.0	8.0	90
Totals:	299.0	314.0	315.0	1,621

Net Volume/Acre: 11.5 MBF

Regeneration Harvest	0.0
Partial Cut	26.0
Right of Way	0.0
Total Acres:	26.0

Unit: 2

Species	Net	Gross Merch	Gross	# of Trees
Douglas Fir	141.0	146.0	146.0	729
Red Alder	2.0	3.0	4.0	43
Totals:	143.0	149.0	150.0	772

Net Volume/Acre: 10.2 MBF

Regeneration Harvest	0.0
Partial Cut	14.0
Right of Way	0.0
Total Acres:	14.0

Unit: 3

Species	Net	Gross Merch	Gross	# of Trees
Douglas Fir	380.0	395.0	396.0	1,968
Red Alder	5.0	9.0	10.0	116
Totals:	385.0	404.0	406.0	2,084

Net Volume/Acre: 12.4 MBF

Regeneration Harvest	0.0
Partial Cut	31.0
Right of Way	0.0
Total Acres:	31.0

Unit: 4

Species	Net	Gross Merch	Gross	# of Trees
Douglas Fir	211.0	220.0	220.0	1,093
Red Alder	3.0	5.0	5.0	64
Totals:	214.0	225.0	225.0	1,157

Net Volume/Acre: 13.4 MBF

Regeneration Harvest	0.0
Partial Cut	16.0
Right of Way	0.0
Total Acres:	16.0

Unit: 5

Species	Net	Gross Merch	Gross	# of Trees
Douglas Fir	346.0	362.0	366.0	1,691
Totals:	346.0	362.0	366.0	1,691

Net Volume/Acre: 17.3 MBF

Regeneration Harvest	0.0
Partial Cut	20.0
Right of Way	0.0
Total Acres:	20.0

Unit: 6

Species	Net	Gross Merch	Gross	# of Trees
Douglas Fir	113.0	117.0	117.0	583
Red Alder	1.0	3.0	3.0	34
Totals:	114.0	120.0	120.0	617

Net Volume/Acre: 12.7 MBF

Regeneration Harvest	0.0
Partial Cut	9.0
Right of Way	0.0
Total Acres:	9.0

Unit: 7

Species	Net	Gross Merch	Gross	# of Trees
Douglas Fir	498.0	520.0	527.0	2,431
Totals:	498.0	520.0	527.0	2,431

Net Volume/Acre: 18.4 MBF

Regeneration Harvest	0.0
Partial Cut	27.0
Right of Way	0.0
Total Acres:	27.0

Unit: 8

Species	Net	Gross Merch	Gross	# of Trees
Douglas Fir	464.0	483.0	483.0	2,505
Red Alder	6.0	11.0	11.0	147
Totals:	470.0	494.0	494.0	2,652

Net Volume/Acre: 10.4 MBF

Regeneration Harvest	0.0
Partial Cut	45.0
Right of Way	0.0
Total Acres:	45.0

Unit: 9

Species	Net	Gross Merch	Gross	# of Trees
Douglas Fir	127.0	132.0	132.0	656
Red Alder	2.0	3.0	3.0	39
Totals:	129.0	135.0	135.0	695

Net Volume/Acre: 14.3 MBF

Regeneration Harvest	0.0
Partial Cut	9.0
Right of Way	0.0
Total Acres:	9.0

Unit: 10

Species	Net	Gross Merch	Gross	# of Trees
Douglas Fir	183.0	190.0	191.0	948
Red Alder	2.0	4.0	5.0	56
Totals:	185.0	194.0	196.0	1,004

Net Volume/Acre: 12.3 MBF

Regeneration Harvest	0.0
Partial Cut	15.0
Right of Way	0.0
Total Acres:	15.0

Unit: 11

Species	Net	Gross Merch	Gross	# of Trees
Douglas Fir	98.0	102.0	103.0	510
Red Alder	1.0	2.0	3.0	30
Totals:	99.0	104.0	106.0	540

Net Volume/Acre: 14.1 MBF

Regeneration Harvest	0.0
Partial Cut	7.0
Right of Way	0.0
Total Acres:	7.0

Unit: 12

Species	Net	Gross Merch	Gross	# of Trees
Douglas Fir	152.0	158.0	160.0	740
Totals:	152.0	158.0	160.0	740

Net Volume/Acre: 19.0 MBF

Regeneration Harvest	0.0
Partial Cut	8.0
Right of Way	0.0
Total Acres:	8.0

Unit: 13

Species	Net	Gross Merch	Gross	# of Trees
Douglas Fir	303.0	316.0	321.0	1,480
Totals:	303.0	316.0	321.0	1,480

Net Volume/Acre: 17.8 MBF

Regeneration Harvest	0.0
Partial Cut	17.0
Right of Way	0.0
Total Acres:	17.0

Unit: 14

Species	Net	Gross Merch	Gross	# of Trees
Douglas Fir	141.0	146.0	147.0	729
Red Alder	2.0	3.0	4.0	43
Totals:	143.0	149.0	151.0	772

Net Volume/Acre: 14.3 MBF

Regeneration Harvest	0.0
Partial Cut	10.0
Right of Way	0.0
Total Acres:	10.0

Unit: 15

Species	Net	Gross Merch	Gross	# of Trees
Douglas Fir	281.0	294.0	298.0	1,374
Totals:	281.0	294.0	298.0	1,374

Net Volume/Acre: 18.7 MBF

Regeneration Harvest	0.0
Partial Cut	15.0
Right of Way	0.0
Total Acres:	15.0

Unit: 16

Species	Net	Gross Merch	Gross	# of Trees
Douglas Fir	127.0	132.0	132.0	656
Red Alder	2.0	3.0	3.0	39
Totals:	129.0	135.0	135.0	695

Net Volume/Acre: 14.3 MBF

Regeneration Harvest	0.0
Partial Cut	9.0
Right of Way	0.0
Total Acres:	9.0

Unit: 17

Species	Net	Gross Merch	Gross	# of Trees
Douglas Fir	225.0	234.0	235.0	1,166
Red Alder	3.0	5.0	6.0	68
Totals:	228.0	239.0	241.0	1,234

Net Volume/Acre: 12.0 MBF

Regeneration Harvest	0.0
Partial Cut	19.0
Right of Way	0.0
Total Acres:	19.0

Unit: 18

Species	Net	Gross Merch	Gross	# of Trees
Douglas Fir	211.0	220.0	220.0	1,093
Red Alder	3.0	5.0	5.0	64
Totals:	214.0	225.0	225.0	1,157

Net Volume/Acre: 12.6 MBF

Regeneration Harvest	0.0
Partial Cut	17.0
Right of Way	0.0
Total Acres:	17.0

Unit: 19

Species	Net	Gross Merch	Gross	# of Trees
Douglas Fir	197.0	205.0	205.0	1,020
Red Alder	3.0	5.0	5.0	60
Totals:	200.0	210.0	210.0	1,080

Net Volume/Acre: 11.8 MBF

Regeneration Harvest	0.0
Partial Cut	17.0
Right of Way	0.0
Total Acres:	17.0

Unit: 20

Species	Net	Gross Merch	Gross	# of Trees
Douglas Fir	183.0	190.0	191.0	948
Red Alder	2.0	4.0	5.0	56
Totals:	185.0	194.0	196.0	1,004

Net Volume/Acre: 14.2 MBF

Regeneration Harvest	0.0
Partial Cut	13.0
Right of Way	0.0
Total Acres:	13.0

Unit: 21

Species	Net	Gross Merch	Gross	# of Trees
Douglas Fir	366.0	381.0	381.0	1,895
Red Alder	5.0	8.0	9.0	111
Totals:	371.0	389.0	390.0	2,006

Net Volume/Acre: 12.8 MBF

Regeneration Harvest	0.0
Partial Cut	29.0
Right of Way	0.0
Total Acres:	29.0

Unit: 22

Species	Net	Gross Merch	Gross	# of Trees
Douglas Fir	211.0	220.0	220.0	1,093
Red Alder	3.0	5.0	5.0	64
Totals:	214.0	225.0	225.0	1,157

Net Volume/Acre: 11.3 MBF

Regeneration Harvest	0.0
Partial Cut	19.0
Right of Way	0.0
Total Acres:	19.0

Unit: 23

Species	Net	Gross Merch	Gross	# of Trees
Douglas Fir	380.0	395.0	396.0	1,968
Red Alder	5.0	9.0	10.0	116
Totals:	385.0	404.0	406.0	2,084

Net Volume/Acre: 12.4 MBF

Regeneration Harvest	0.0
Partial Cut	31.0
Right of Way	0.0
Total Acres:	31.0

Unit: 24

Species	Net	Gross Merch	Gross	# of Trees
Douglas Fir	368.0	384.0	389.0	1,797
Totals:	368.0	384.0	389.0	1,797

Net Volume/Acre: 19.4 MBF

Regeneration Harvest	0.0
Partial Cut	19.0
Right of Way	0.0
Total Acres:	19.0

Unit: 25

Species	Net	Gross Merch	Gross	# of Trees
Douglas Fir	197.0	205.0	205.0	1,020
Red Alder	3.0	5.0	5.0	60
Totals:	200.0	210.0	210.0	1,080

Net Volume/Acre: 11.8 MBF

Regeneration Harvest	0.0
Partial Cut	17.0
Right of Way	0.0
Total Acres:	17.0

Unit: 26

Species	Net	Gross Merch	Gross	# of Trees
Douglas Fir	3,997.0	4,130.0	4,130.0	9,754
Noble Fir	1,084.0	1,154.0	1,155.0	1,837
Bigleaf Maple	4.0	6.0	6.0	138
Totals:	5,085.0	5,290.0	5,291.0	11,729

Net Volume/Acre: 35.8 MBF

Regeneration Harvest	103.0
Partial Cut	39.0
Right of Way	0.0
Total Acres:	142.0

Unit: 27

Species	Net	Gross Merch	Gross	# of Trees
Douglas Fir	1,027.0	1,061.0	1,061.0	5,021
Noble Fir	153.0	160.0	162.0	208
Bigleaf Maple	2.0	4.0	4.0	40
Totals:	1,182.0	1,225.0	1,227.0	5,269

Net Volume/Acre: 16.6 MBF

Regeneration Harvest	0.0
Partial Cut	71.0
Right of Way	0.0
Total Acres:	71.0

Unit: 28

Species	Net	Gross Merch	Gross	# of Trees
Douglas Fir	171.0	177.0	177.0	837
Noble Fir	26.0	27.0	27.0	35
Totals:	197.0	204.0	204.0	872

Net Volume/Acre: 16.4 MBF

Regeneration Harvest	0.0
Partial Cut	12.0
Right of Way	0.0
Total Acres:	12.0

Unit: 29

Species	Net	Gross Merch	Gross	# of Trees
Douglas Fir	2,926.0	3,022.0	3,022.0	14,302
Noble Fir	437.0	457.0	462.0	593
Bigleaf Maple	5.0	12.0	13.0	113
Totals:	3,368.0	3,491.0	3,497.0	15,008

Net Volume/Acre: 16.9 MBF

Regeneration Harvest	0.0
Partial Cut	199.0
Right of Way	0.0
Total Acres:	199.0

Unit: RW2

Species	Net	Gross Merch	Gross	# of Trees
Douglas Fir	211.0	218.0	218.0	681
Noble Fir	11.0	12.0	12.0	12
Bigleaf Maple	1.0	1.0	1.0	8
Totals:	223.0	231.0	231.0	701

Net Volume/Acre: 111.5 MBF

Regeneration Harvest	0.0
Partial Cut	0.0
Right of Way	2.0
Total Acres:	2.0

Unit: RW

Species	Net	Gross Merch	Gross	# of Trees
Douglas Fir	495.0	520.0	520.0	1,747
Western Hemlock	72.0	77.0	77.0	85
Red Alder	6.0	8.0	9.0	145
Totals:	573.0	605.0	606.0	1,977

Net Volume/Acre: 95.5 MBF

Regeneration Harvest	0.0
Partial Cut	0.0
Right of Way	6.0
Total Acres:	6.0

Comments:

Acres on cruise report do not match acres in appraisal. 95 acres of clumps were removed from the cruise.

Total Stump To Truck	Net Volume	\$/MBF
\$3,730,182.67	16,883.0	\$220.94

Stump to Truck: Falling, Bucking, Yarding, & Loading

Yarding System	Unit of Measure	# of Units of Measure	\$/Unit of Measure	Total Cost	Remarks
Cable: Medium Yarder	GM MBF	2,093.0	\$319.26	\$668,211.18	Cable units <15 MBF/Acre
Feller Buncher/Track Skidder	GM MBF	3,227.0	\$287.17	\$926,697.59	ground units <15 MBF/Acre
Cable: Medium Yarder	GM MBF	770.0	\$255.41	\$196,665.70	cable units >16 MBF/Acre
Feller Buncher/Track Skidder	GM MBF	6,171.0	\$205.12	\$1,265,795.52	ground units >16 MBF/Acre
Shovel	GM MBF	836.0	\$138.76	\$116,003.36	RW & RW2
Feller Buncher/Track Skidder	GM MBF	4,502.0	\$119.66	\$538,709.32	ground regen unit 26
Subtotal				\$3,712,082.67	

Additional Costs

Item	Unit of Measure	# of Units of Measure	\$/Unit of Measure	Total Cost	Remarks
Intermediate Support	Each	37.0	\$300.00	\$11,100.00	
Subtotal				\$11,100.00	

Additional Moves

Equipment	Unit of Measure	# of Units of Measure	\$/Unit of Measure	Total Cost	Remarks
Cable: Medium Yarder	Each	2.0	\$1,500.00	\$3,000.00	
Shovel	Each	2.0	\$1,200.00	\$2,400.00	
Track Skidder	Each	2.0	\$800.00	\$1,600.00	
Subtotal				\$7,000.00	

Total	Net Volume	\$/MBF
\$839,040.00	16,883.0	\$49.70

Utilization Center	One Way Mileage	Description	Unit of Measure	# of Units	\$/Unit of Measure	Total Cost	% of Sale Volume
Garibaldi	51.0	Alder/Maple	GM MBF	130.0	\$71.25	\$9,262.50	1%
Willamina	25.0	Fir/Hemlock	GM MBF	17,469.0	\$47.50	\$829,777.50	99%

Engineering Allowances

Total	Net Volume	\$/MBF
\$1,873,589.30	16,883.0	\$110.97

Cost Item	Total Cost
Road Construction:	\$1,685,066.87
Road Maintenance/Rockwear:	\$188,522.43
Road Use Fees:	\$0.00

Total	Net Volume	\$/MBF
\$343,000.00	16,883.0	\$20.32

Environmental Protection

Cost item	Total Cost
Machine Washing	\$400.00
CWD Costs	\$222,600.00
Subtotal	\$223,000.00

Logging

Cost item	Total Cost
Road side flagging	\$20,700.00
Fuel reduction cost	\$99,300.00
Subtotal	\$120,000.00

Comments:

See CWD appraisal for detailed appraisal info.

See Fuels appraisal for additional info.